



PRODUCT OVERVIEW

Open with Adobe Acrobat on desktop computers

WALL INLETS

135-VFR	→
135-FR	→
145-VFG	→
145-VFG-C	→
145-VFR	→
145-VFR-C	→
145-VFGD	→
145-VFRD	→
145-VFGT	→
145-VFRT	→
145-FG	→
145-FR	→
1800-VFG-C	→

VENTILATION CONCEPTS

2000-PBR-C	→
2500-PVF(T)	→
2800-VFRM	→
3000-VFG-C	→
3000-VFBR-C	→
3000-VFBG-C	→
4000-VFG-C	→
AERON	→
OMNIFLUX	→
OMNISTEP	→
VENTUM	→
VUELA	→
WIND HOODS, LIGHT TRAPS & AIR GUIDES	
Wind hoods and Light traps	→
Air guides	→

TUNNEL UNITS

6000-VFG	→
6000-VFG-C	→
6000-VFR	→
6000-VFR-C	→
6000-VFG-2	→
6000-VFG-2-C	→
6000-VFG-3	→
6000-VFG-3-C	→
6000-VFG-4	→
6000-VFG-4-C	→
6000-VFR-2	→
6000-VFR-2-C	→
6000-VFR-3	→
6000-VFR-3-C	→

6000-VFR-4	→
6000-VFR-4-C	→
VENTUM-2	→
VENTUM-3	→
VENTUM-4	→
VENTUM-5	→

CEILING INLETS

84-P-C	→
120-P-C	→
160-P-C	→
160-PD-C	→
180-P-C	→
220-P	→

MAIN CABLES & ACCESSORIES

Main Cable Self Opening & Self Closing	→
--	-------------------

135-VFR

This inlet is suitable for almost all applications. With a bottom hinged and straight inner valve the air is guided upwards during minimum ventilation. Even during maximum ventilation the air is never guided downwards to the animals. The inlet is controlled by means of an aluminum side arm.

(also available in self-closing version. See the ventilation concepts page for more information)

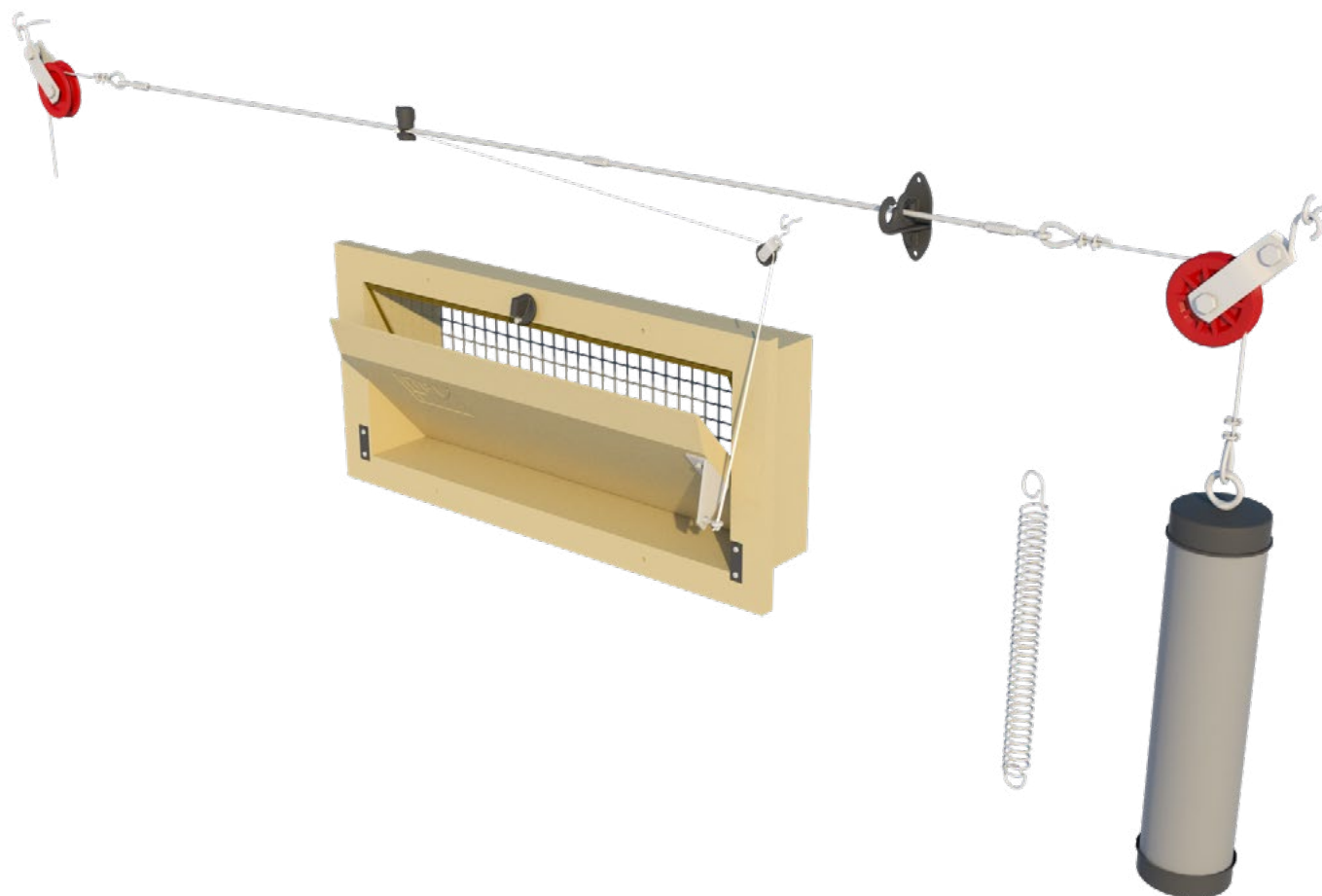

INFO

DATASHEET

ASSEMBLY

MOUNTING

WORKING

MAINTENANCE



CAPACITY

Model	m ³ /h @ 10 Pa	m ³ /h @ 20 Pa	m ³ /h @ 40 Pa
135-VFR	1450	2050	2900
	cfm @ 0.05 inH ₂ O	cfm @ 0.1 inH ₂ O	cfm @ 0.15 inH ₂ O
	954	1346	1648

INFORMATION

Run	17 cm / 6.5 inch
Force	2 kg / 19.6 Newton
Number / pallet (1.20 x 0.80 x 2.40 m / 47 x 31,5 x 94,5 inch)	48
Weight / per inlet	2,5 kg / 5.50 lbs
Volume / per box	24

OPTIONAL ACCESSORIES

TPI-101	Wire mesh galvanized
TPI-109	Wire mesh synthetic
TPI-204	Connection set
TPI-307	Closing catch + spring
TPI-408	Hanging pulley
TPI-702	Counter flange for inlets in 135/145-series

AIR FLOW

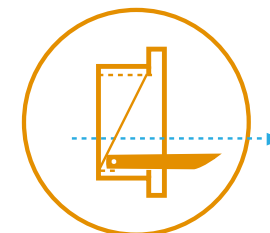
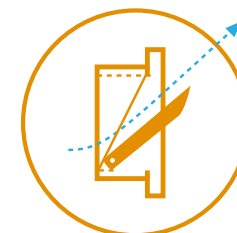



TPI-621 (part of 205)

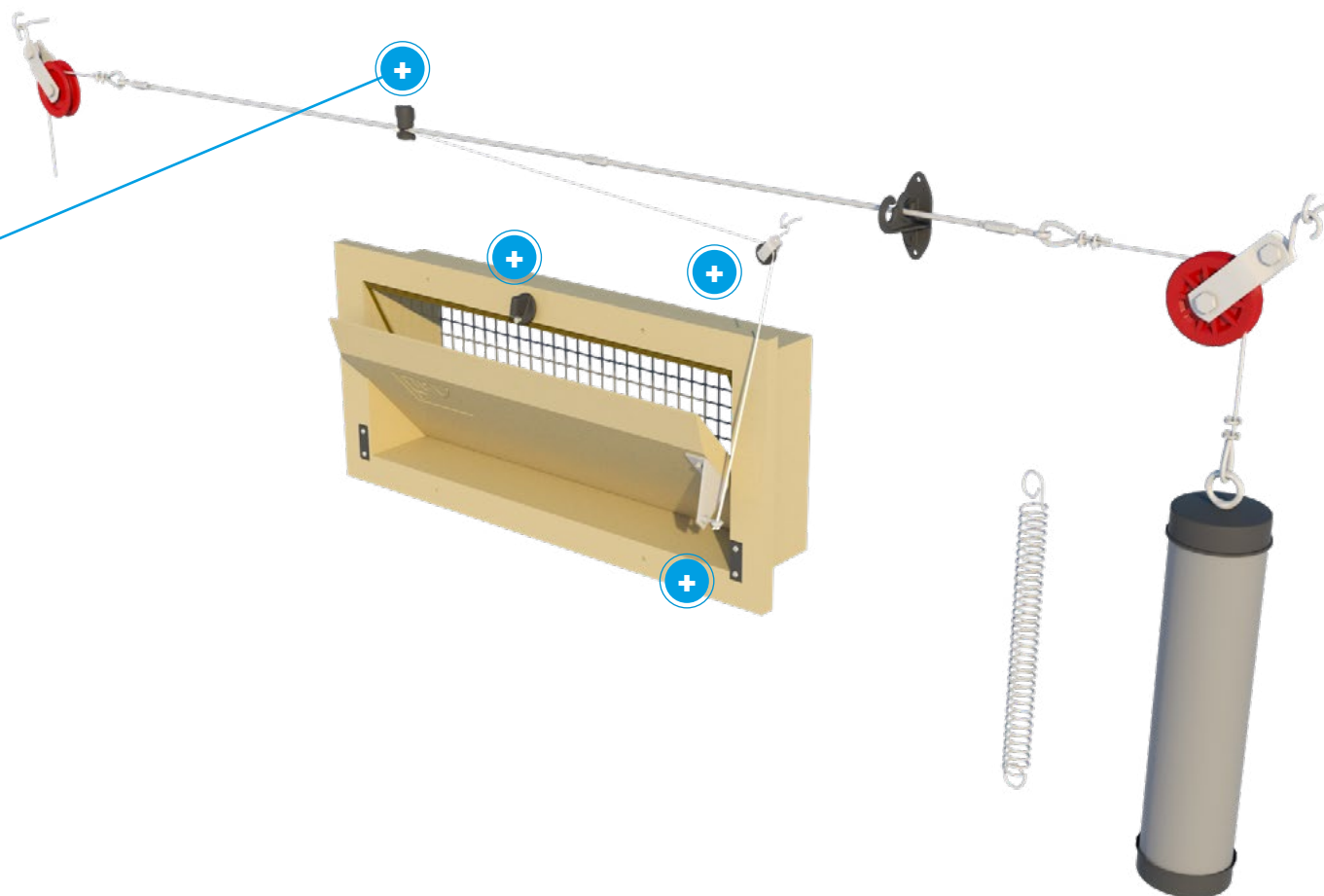

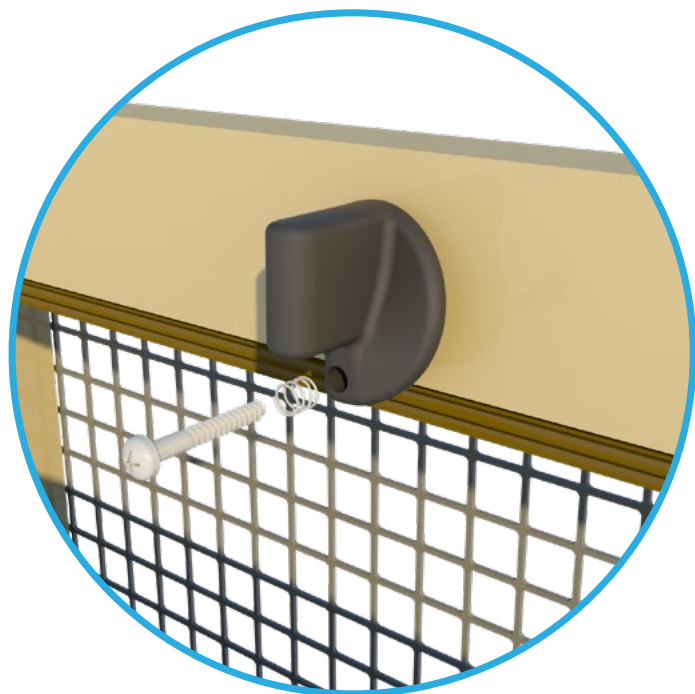

TPI-307

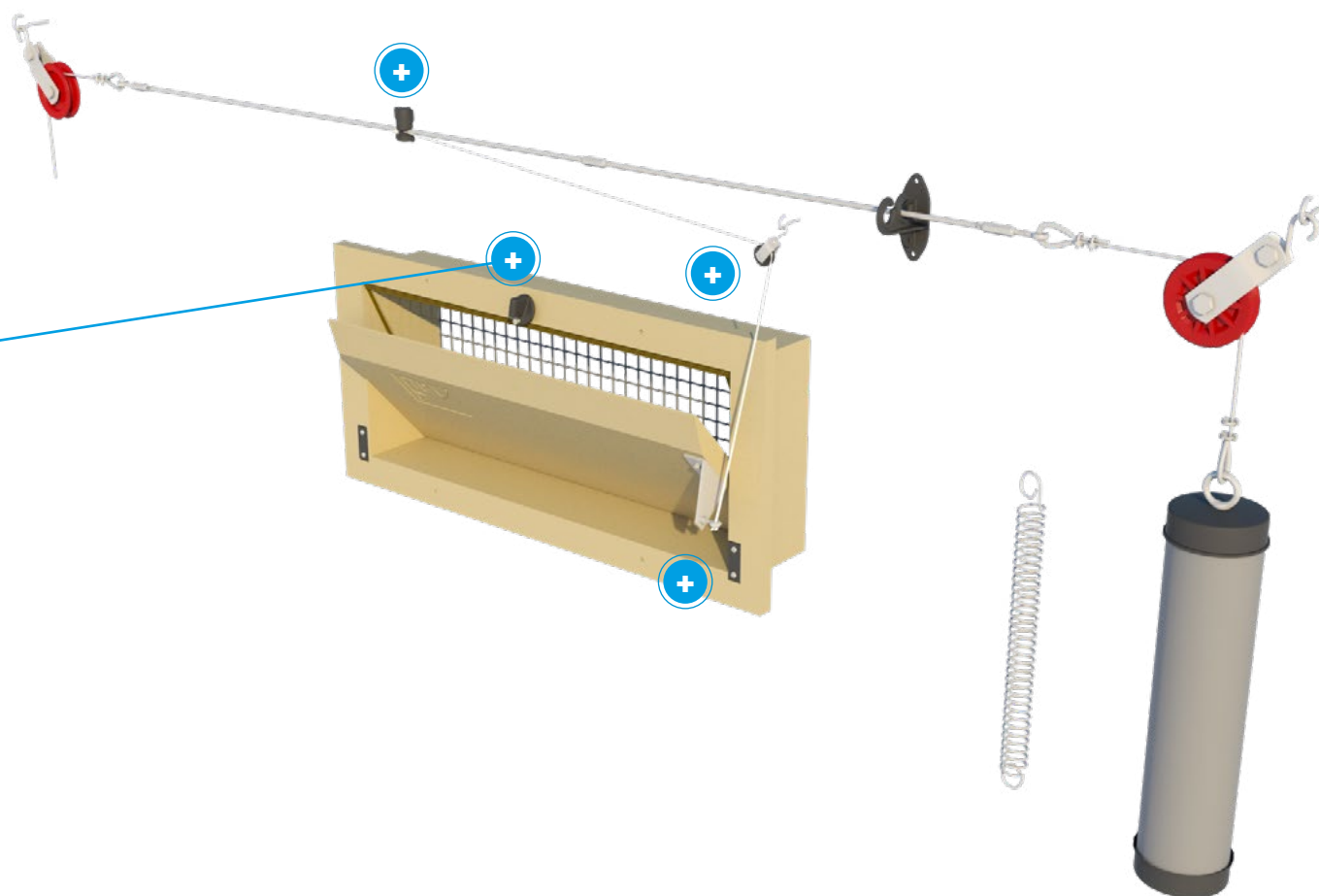

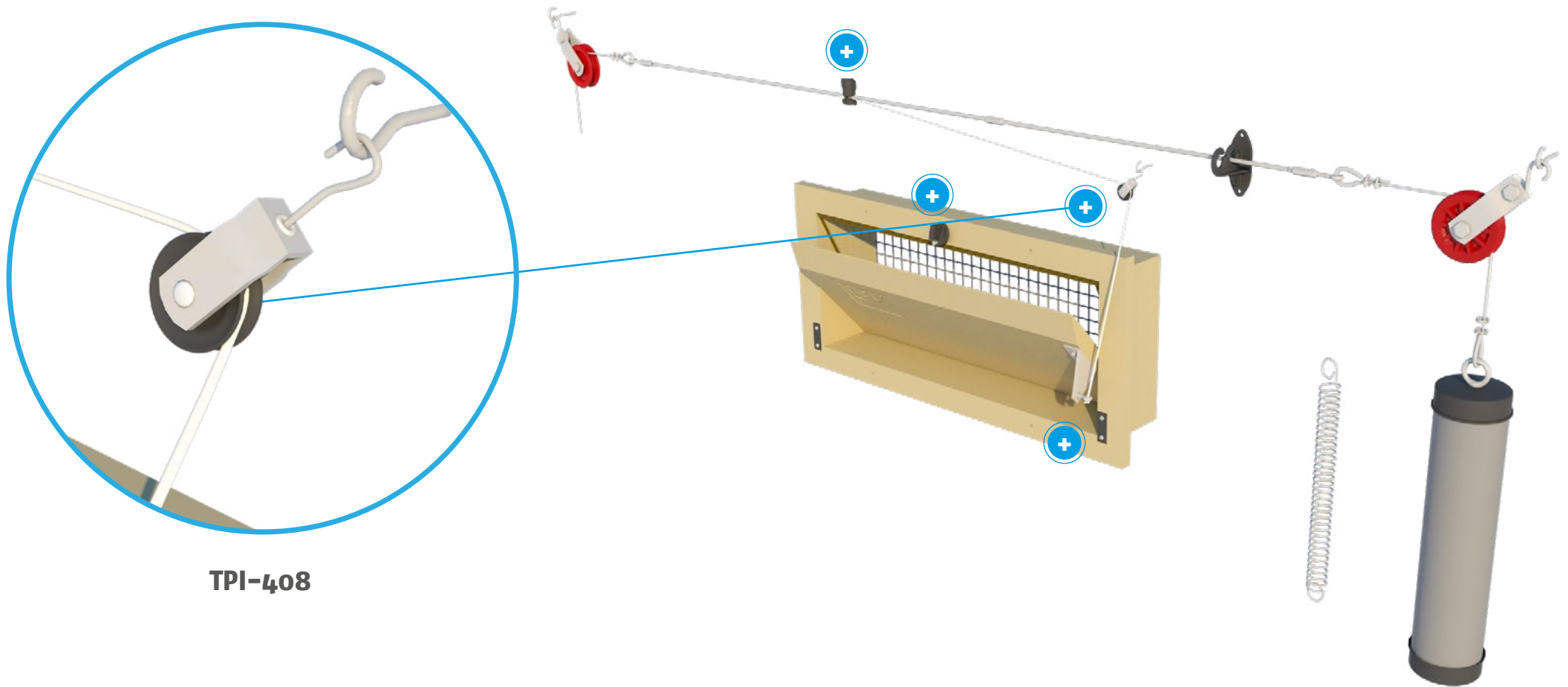

INFO

DATASHEET

ASSEMBLY

MOUNTING

WORKING

MAINTENANCE





TPI-205 (Including TPI 621)

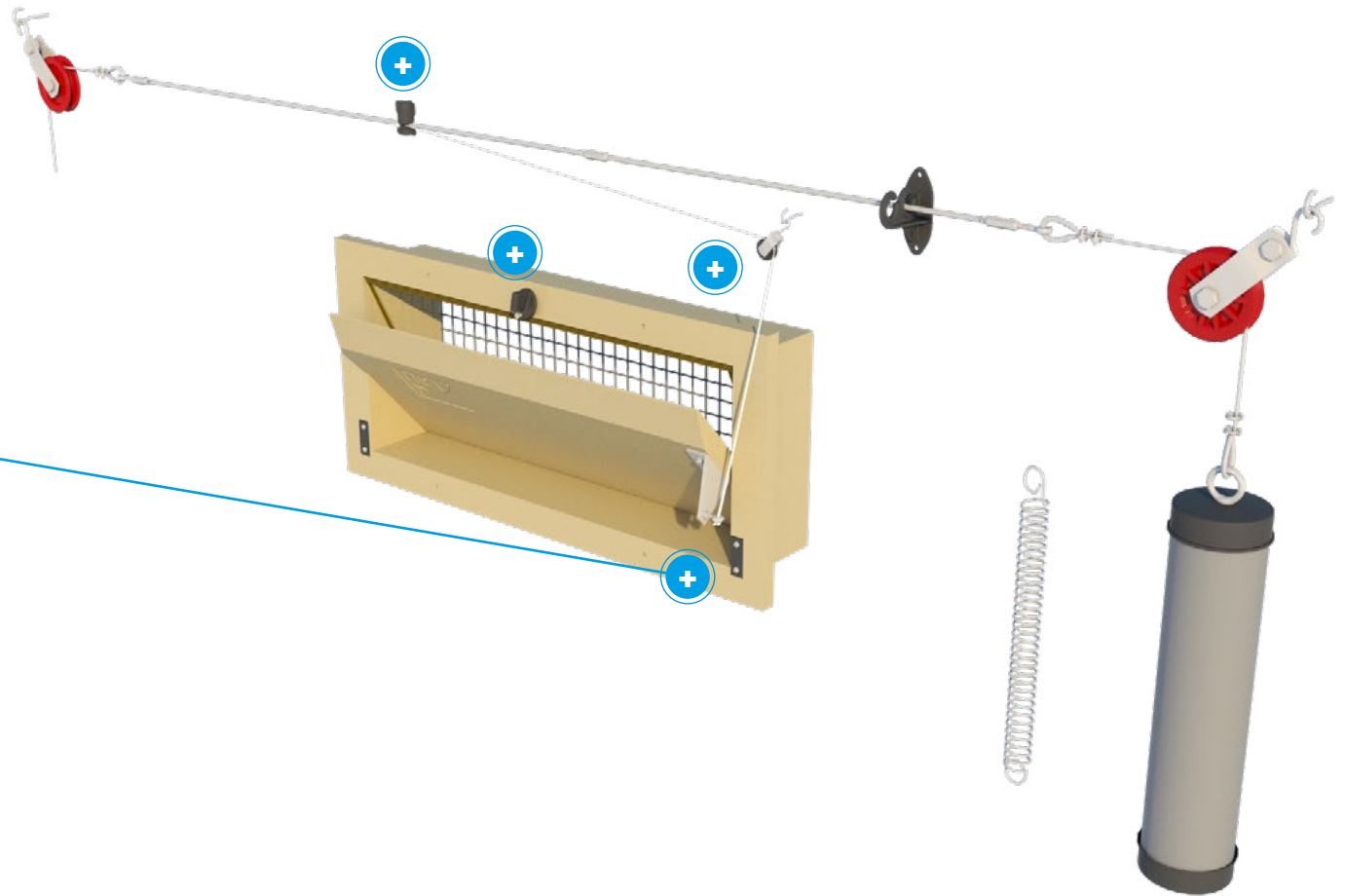

All sizes are in cm and inches

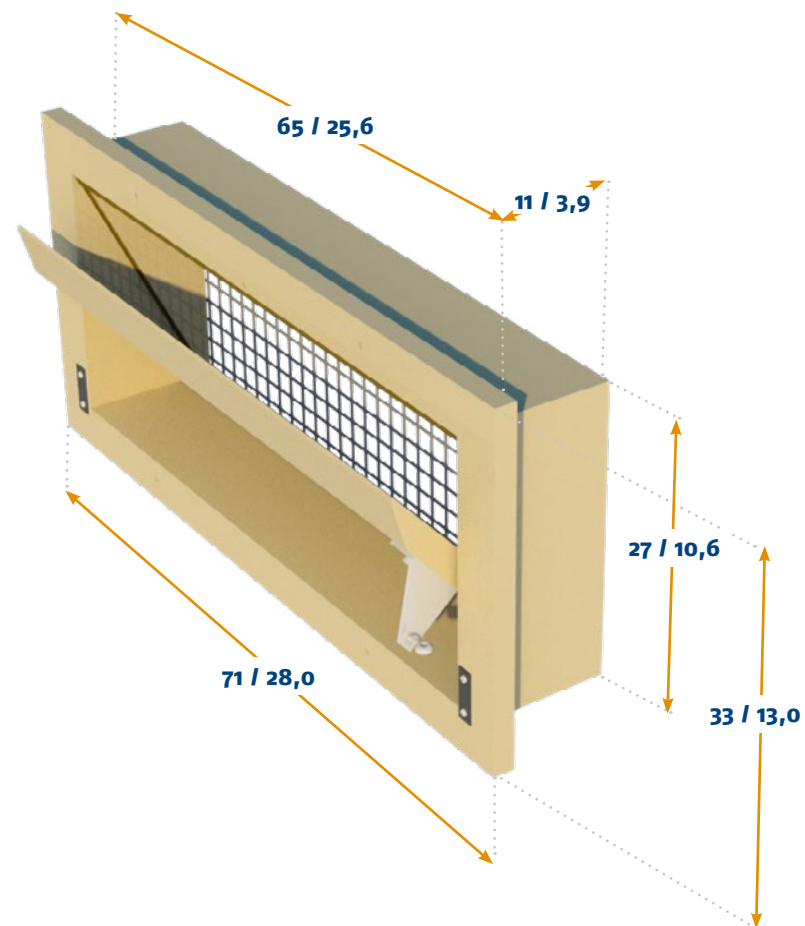
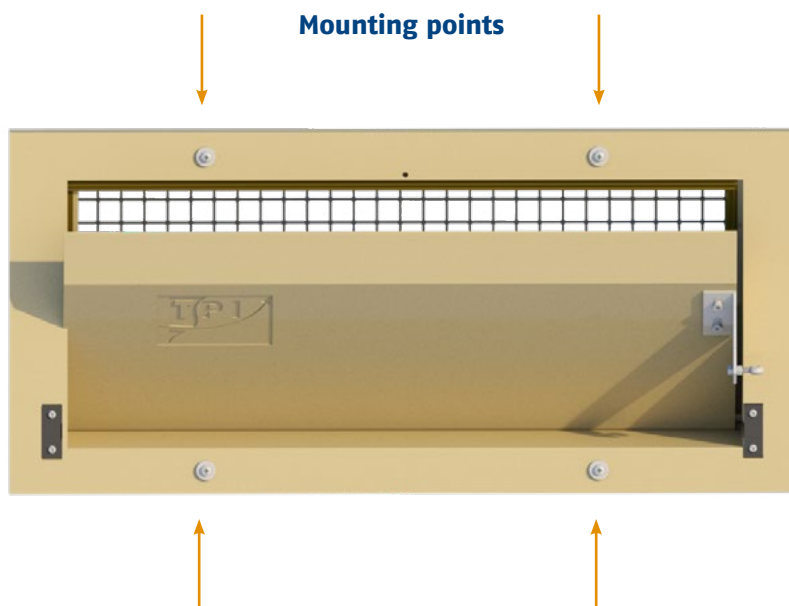

MOUNTING

Mounting type	Wall
Mounting hole size	67 cm / 26,4 inch x 29 cm / 11,4 inch

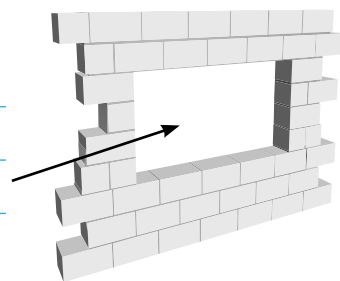

INFO

DATASHEET

ASSEMBLY

MOUNTING

WORKING

MAINTENANCE



AIR FLOW

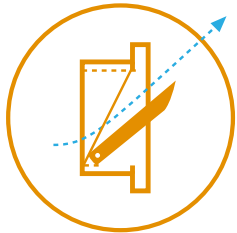

Bottom hinged inlet

This bottom hinged inlet is made to guide air over the inner flap upwards into the house. This inlet is perfectly suitable for colder climates where air is not meant to be directed towards the animals, even during maximum ventilation.

Straight inner flap

This inlet is equipped with a straight inner flap. Straight flaps guide air in a straight upwards or horizontal direction, never downwards. This is ideal for houses where air should not be directed directly towards or over the animals during maximum ventilation.

Working with end-weights or springs

We offer two products which can be used to keep tension on the main cable. A PVC cylinder which can be filled with concrete or sand to act as end-weight, or a spring that holds tension on the cable.

Balanced set-up

When placing the motor winch or actuator we normally suggest to divide the inlets in two groups. It is preferable to place the winch or actuator in the middle to equally divide the forces on the main cable.

(see ventilation concepts page for an example)

Use of closing catches

The closing catch on the inlet can be used to permanently close inlets for example during pre-heating. The closing catches can also be used to close certain inlets while continuing to use others. In that case the used inlets can be opened a bit further. In colder climates this can help to offer better resistance to freezing effects.

Self-closing concept

This inlet is also available as a self-closing version. See the ventilation concepts page for more information.

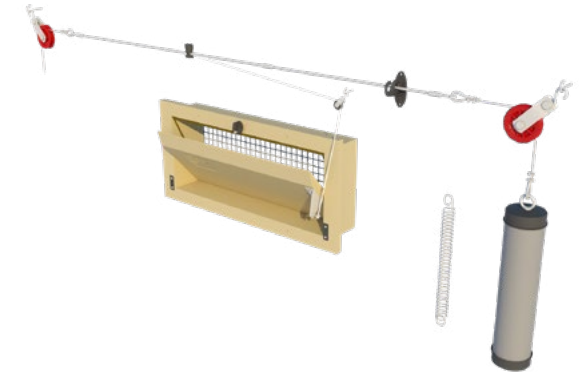

INFO

DATASHEET

ASSEMBLY

MOUNTING

WORKING

MAINTENANCE



135-FR

This inlet has a flange on the backside of the house so it can be built onto the wall instead of being built in the wall. With a bottom hinged and straight inner valve the air is guided upwards during minimum ventilation. Even during maximum ventilation the air is never guided downwards to the animals. The inlet is controlled by means of an aluminum side arm.

(also available in self-closing version. See the ventilation concepts page for more information)

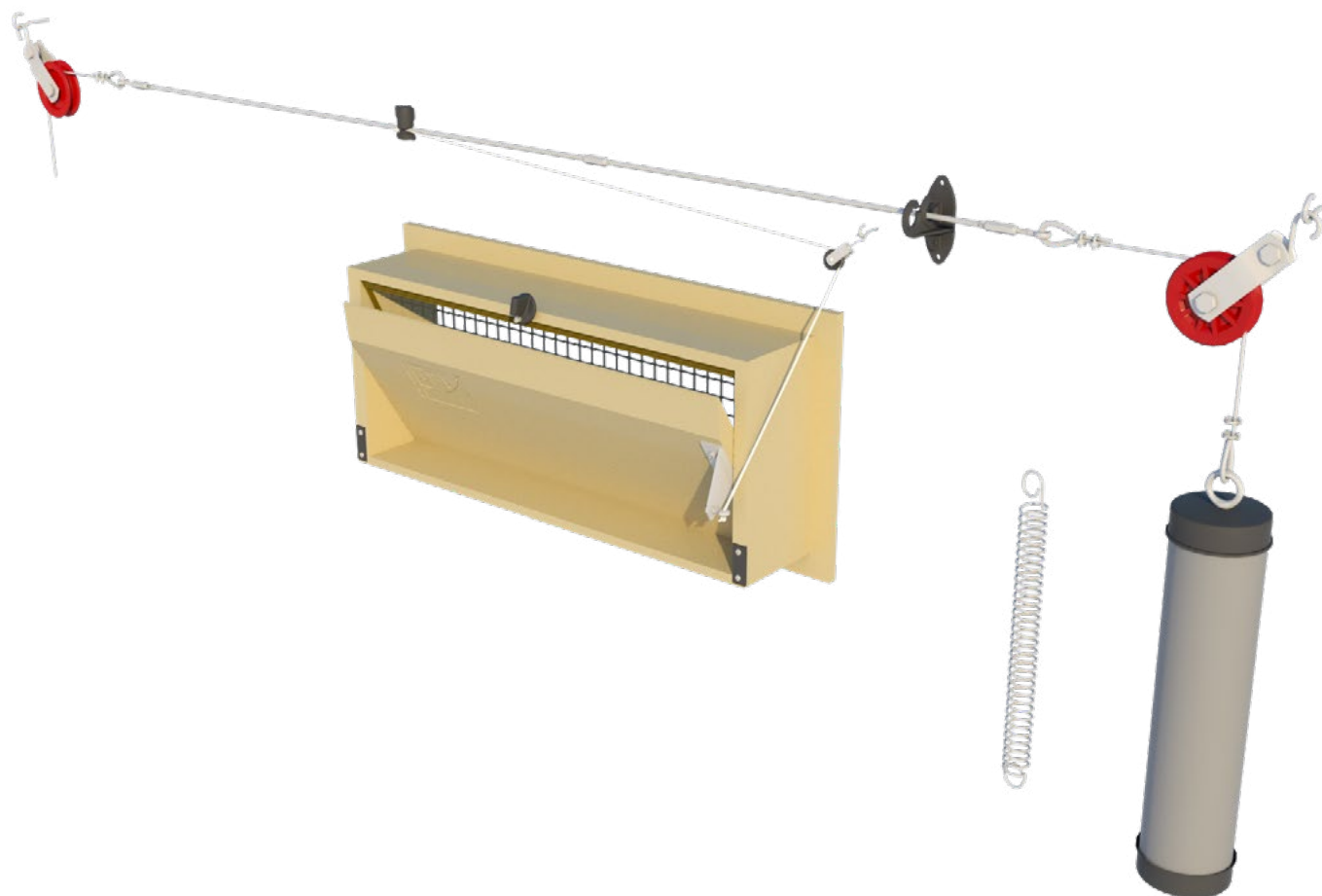

INFO

DATASHEET

ASSEMBLY

MOUNTING

WORKING

MAINTENANCE



CAPACITY

Model	m ³ /h @ 10 Pa	m ³ /h @ 20 Pa	m ³ /h @ 40 Pa
135-FR	1450	2050	2900
	cfm @ 0.05 inH ₂ O	cfm @ 0.1 inH ₂ O	cfm @ 0.15 inH ₂ O
	954	1346	1648

INFORMATION

Run	17 cm / 6.5 inch
Force	2 kg / 19.6 Newton
Number / pallet (1,20 x 0,80 x 2,40m / 47 x 31,5 x 94,5 inch)	48
Weight / per inlet	2,5 kg / 5.50 lbs
Volume / per box	24

OPTIONAL ACCESSORIES

TPI-101	Wire mesh galvanized
TPI-109	Wire mesh synthetic
TPI-204	Connection set
TPI-307	Closing catch + spring
TPI-408	Hanging pulley
TPI-702	Counter flange for inlets in 135/145-series

AIR FLOW

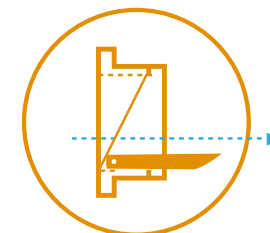
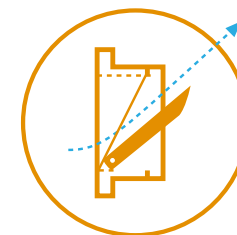



TPI-204

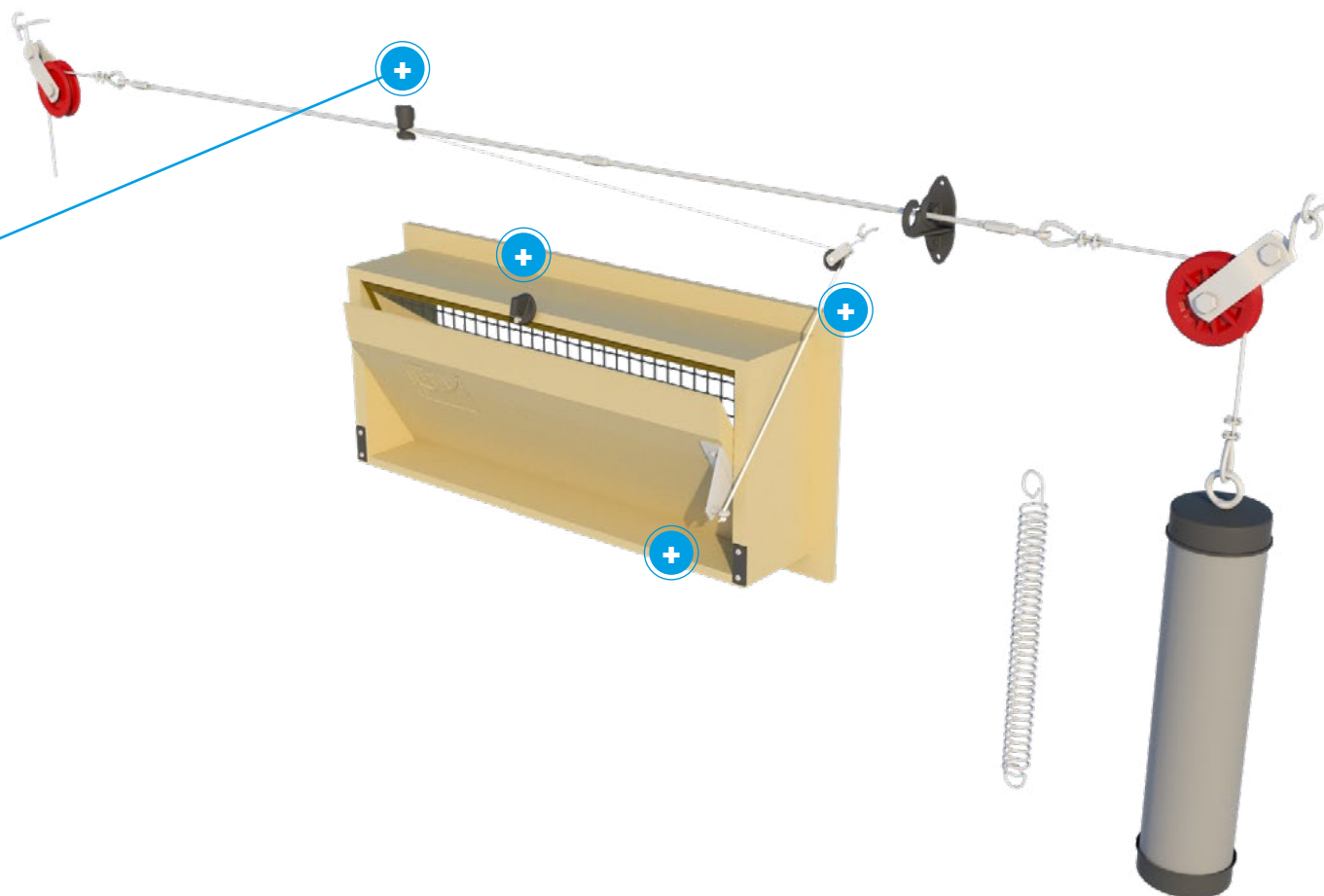

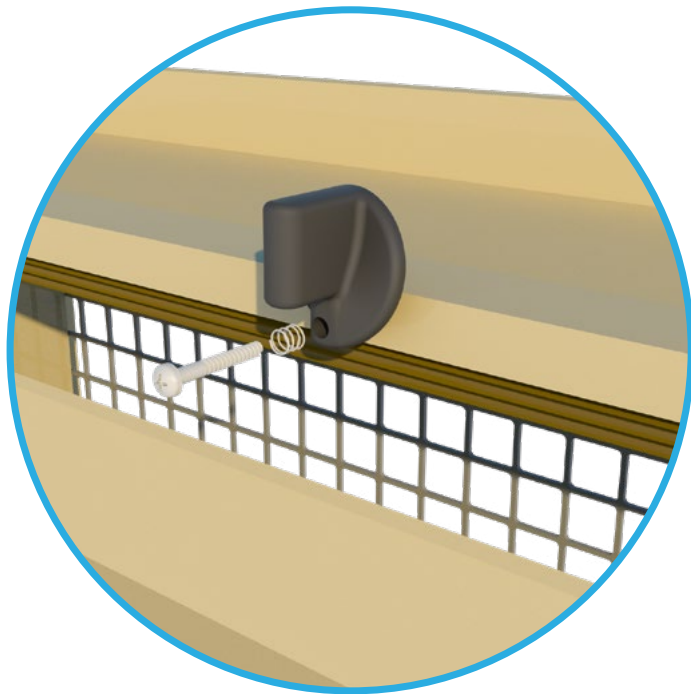

TPI-307

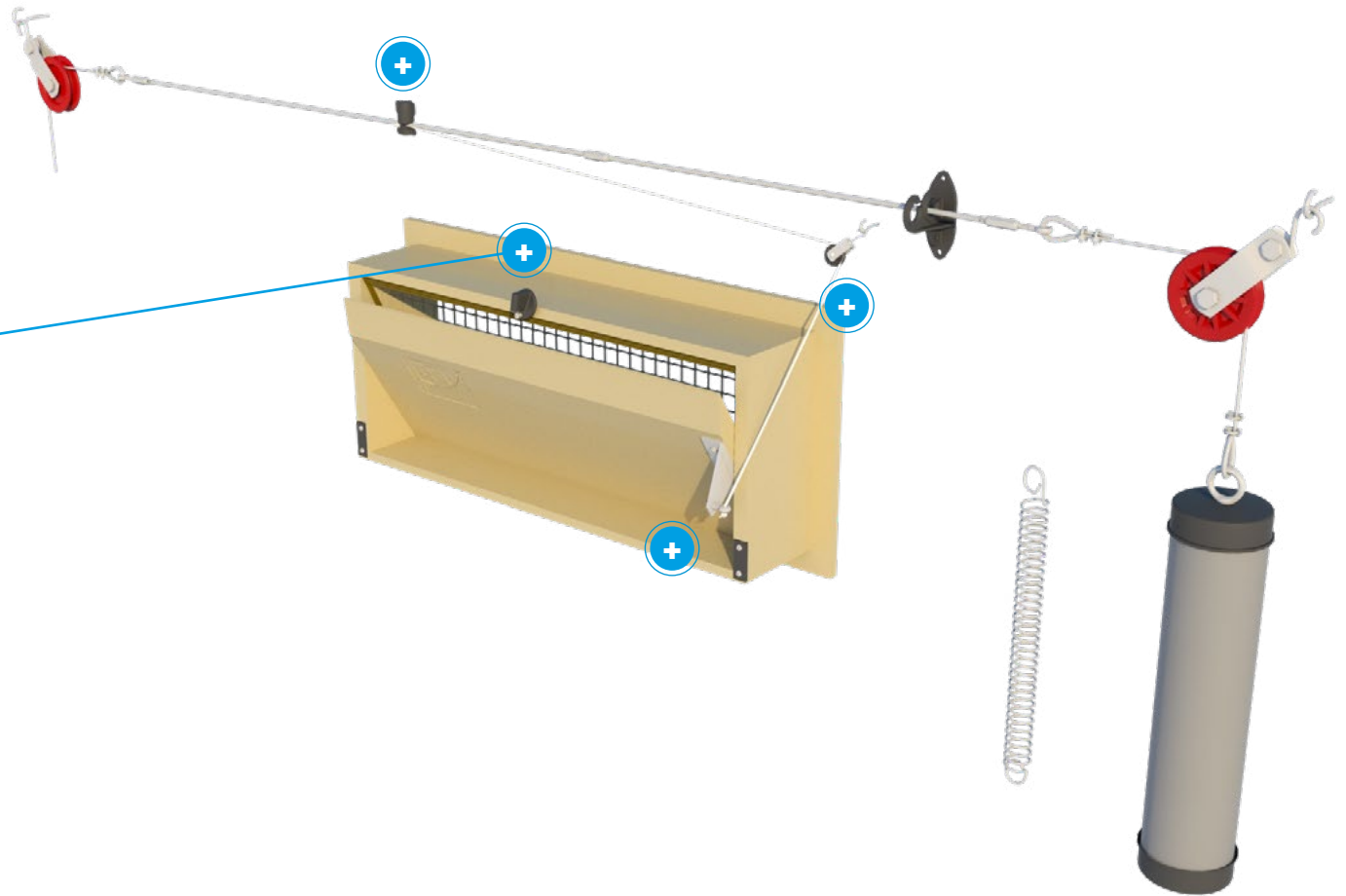

INFO

DATASHEET

ASSEMBLY

MOUNTING

WORKING

MAINTENANCE



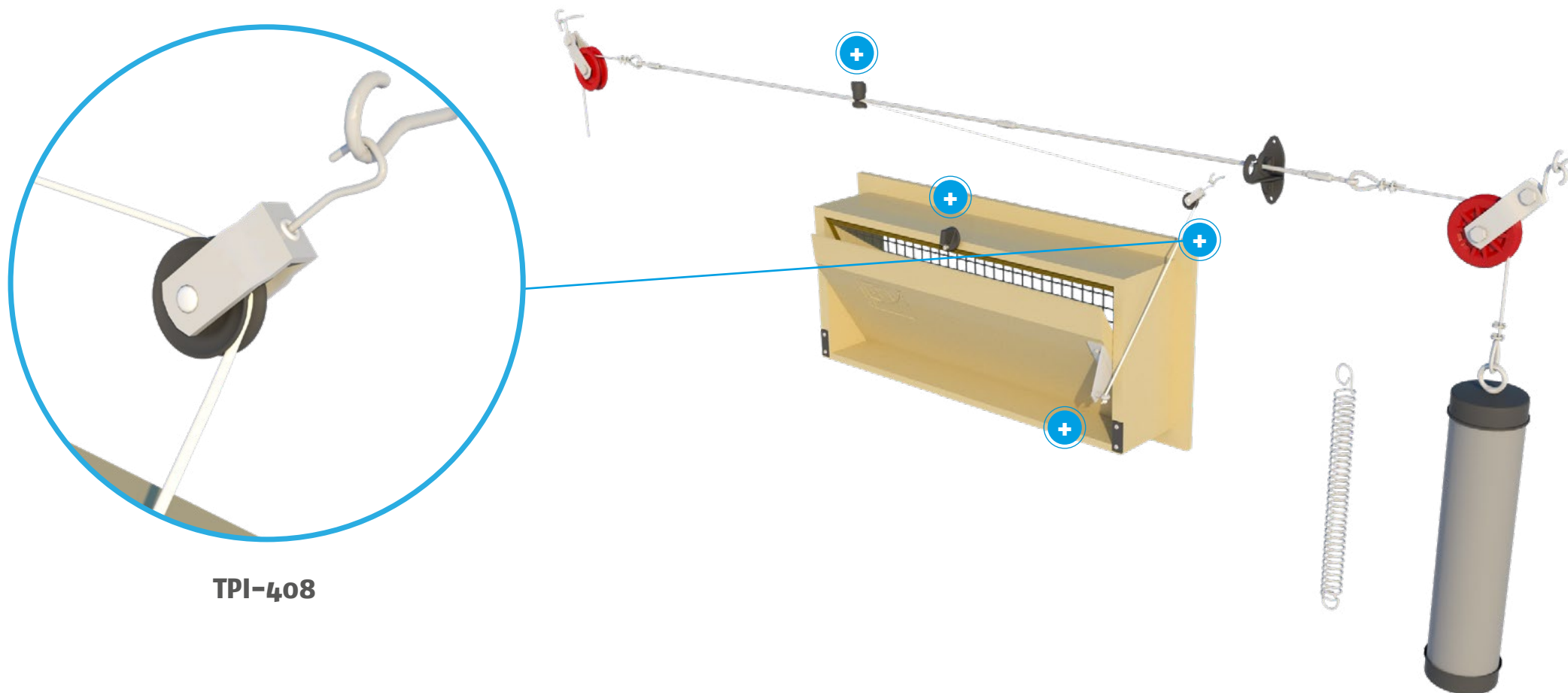

INFO

DATASHEET

ASSEMBLY

MOUNTING

WORKING

MAINTENANCE



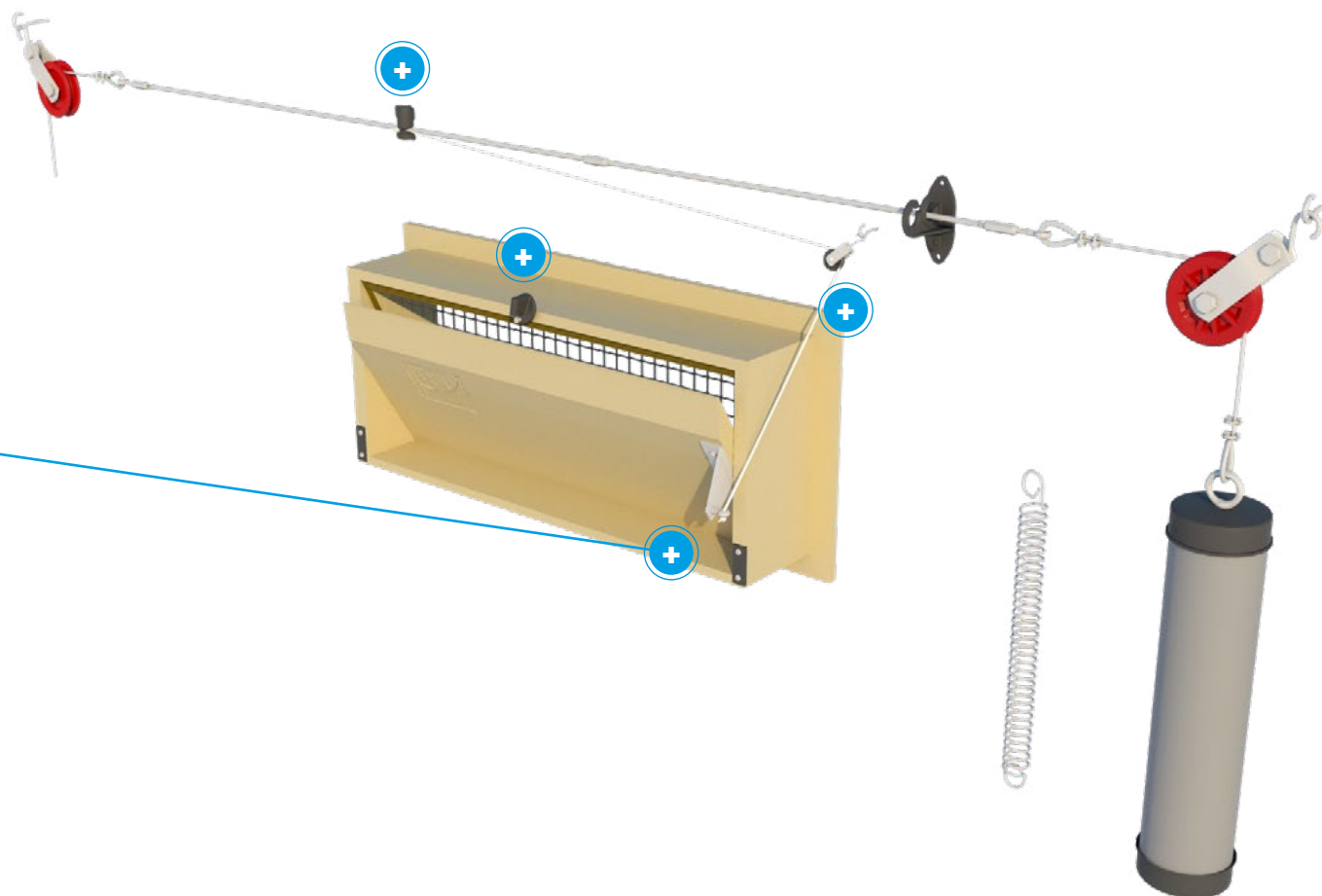
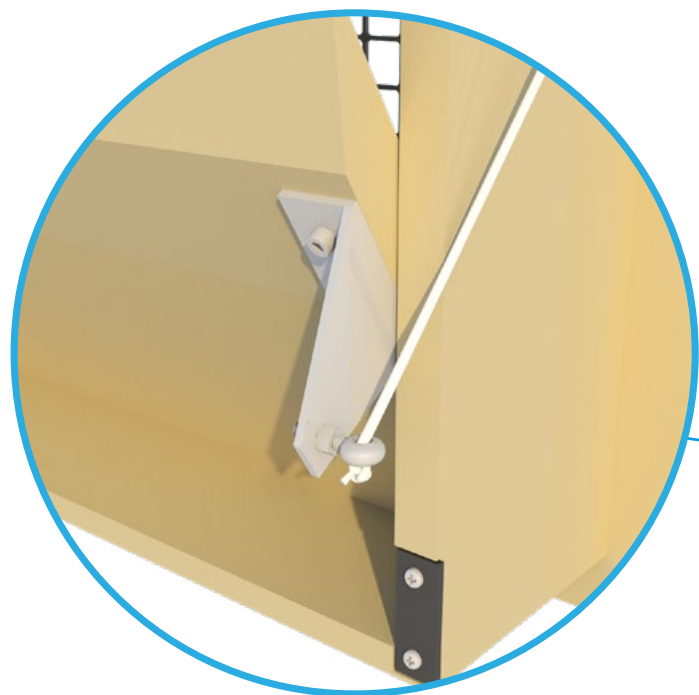

All sizes are in cm and inches

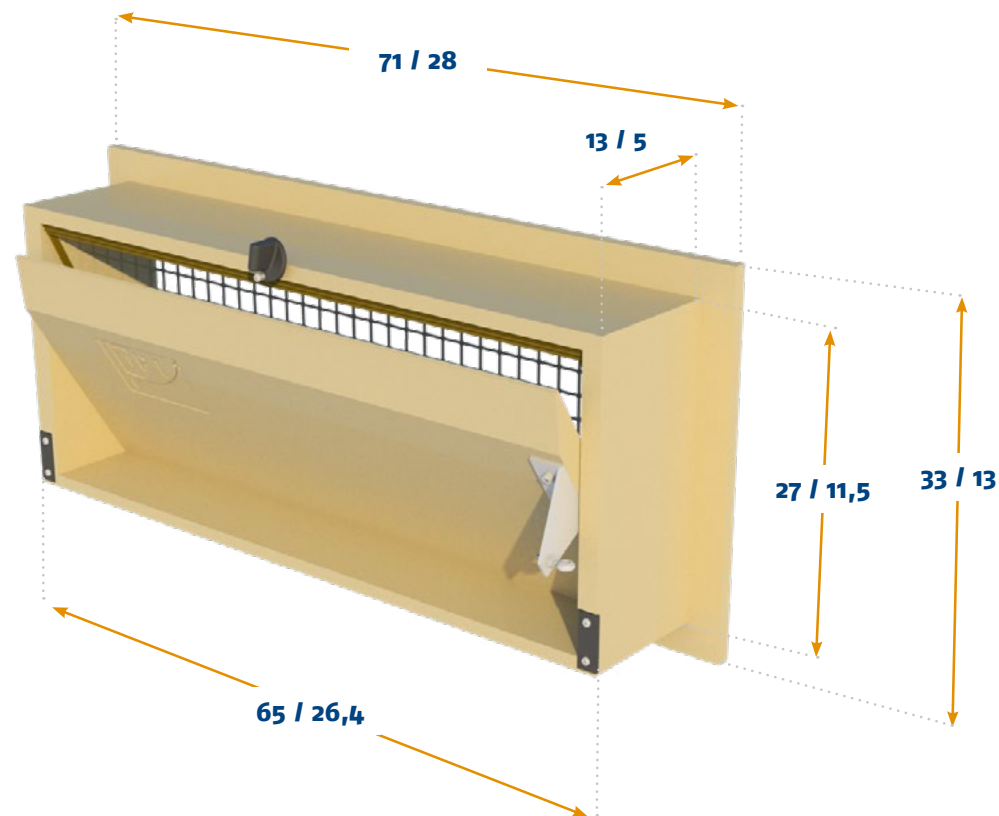
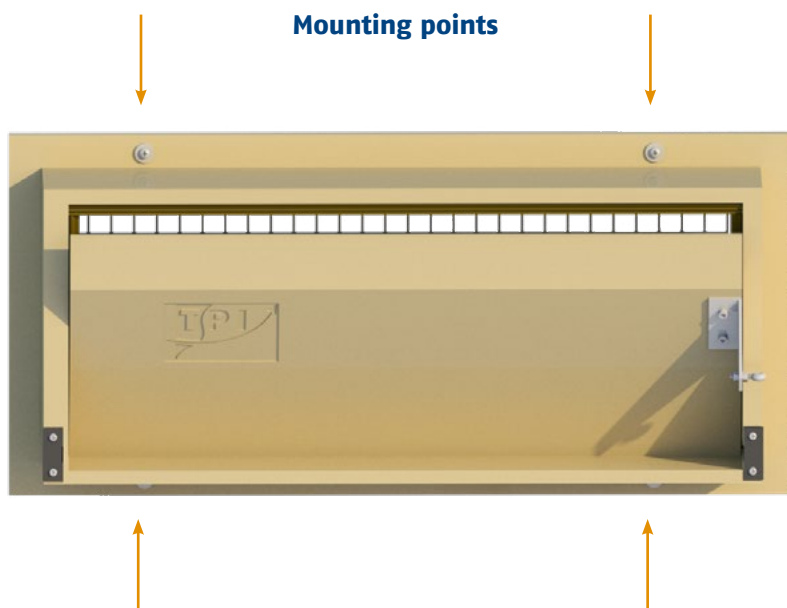

MOUNTING

Mounting type	Wall
Max. hole size in wall	76 cm / 26,4 inch x 29 cm / 11,4 inch

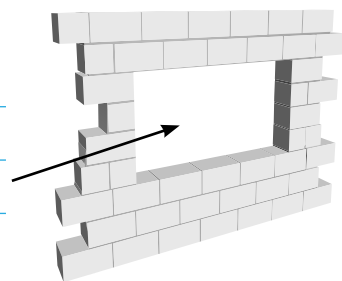

INFO

DATASHEET

ASSEMBLY

MOUNTING

WORKING

MAINTENANCE



AIR FLOW

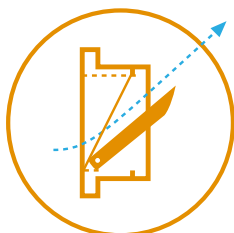

Bottom hinged inlet

This bottom hinged inlet is made to guide air over the inner flap upwards into the house. This inlet is perfectly suitable for colder climates where air is not meant to be directed towards the animals, even during maximum ventilation.

Straight inner flap

This inlet is equipped with a straight inner flap. Straight flaps guide air in a straight upwards or horizontal direction, never downwards. This is ideal for houses where air should not be directed directly towards or over the animals during maximum ventilation.

Working with end-weights or springs

We offer two products which can be used to keep tension on the main cable. A PVC cylinder which can be filled with concrete or sand to act as end-weight, or a spring that holds tension on the cable.

Balanced set-up

When placing the motor winch or actuator we normally suggest to divide the inlets in two groups. It is preferable to place the winch or actuator in the middle to equally divide the forces on the main cable.

(see ventilation concepts page for an example)

Use of closing catches

The closing catch on the inlet can be used to permanently close inlets for example during pre-heating. The closing catches can also be used to close certain inlets while continuing to use others. In that case the used inlets can be opened a bit further. In colder climates this can help to offer better resistance to freezing effects.

Self-closing concept

This inlet is also available as a self-closing version. See the ventilation concepts page for more information.



INFO

DATASHEET

ASSEMBLY

MOUNTING

WORKING

MAINTENANCE



145-VFG

This inlet is suitable for almost all applications. With a middle hinged inner valve the air will be divided and also flows underneath the valve when it is opened over 35%. The inlet is controlled by means of a stainless steel side arm. This inlet is executed with a curved inner valve so when it is opened for maximum ventilation air is also guide downwards to the animals.

(also available in self-closing version. See the ventilation concepts page for more information)

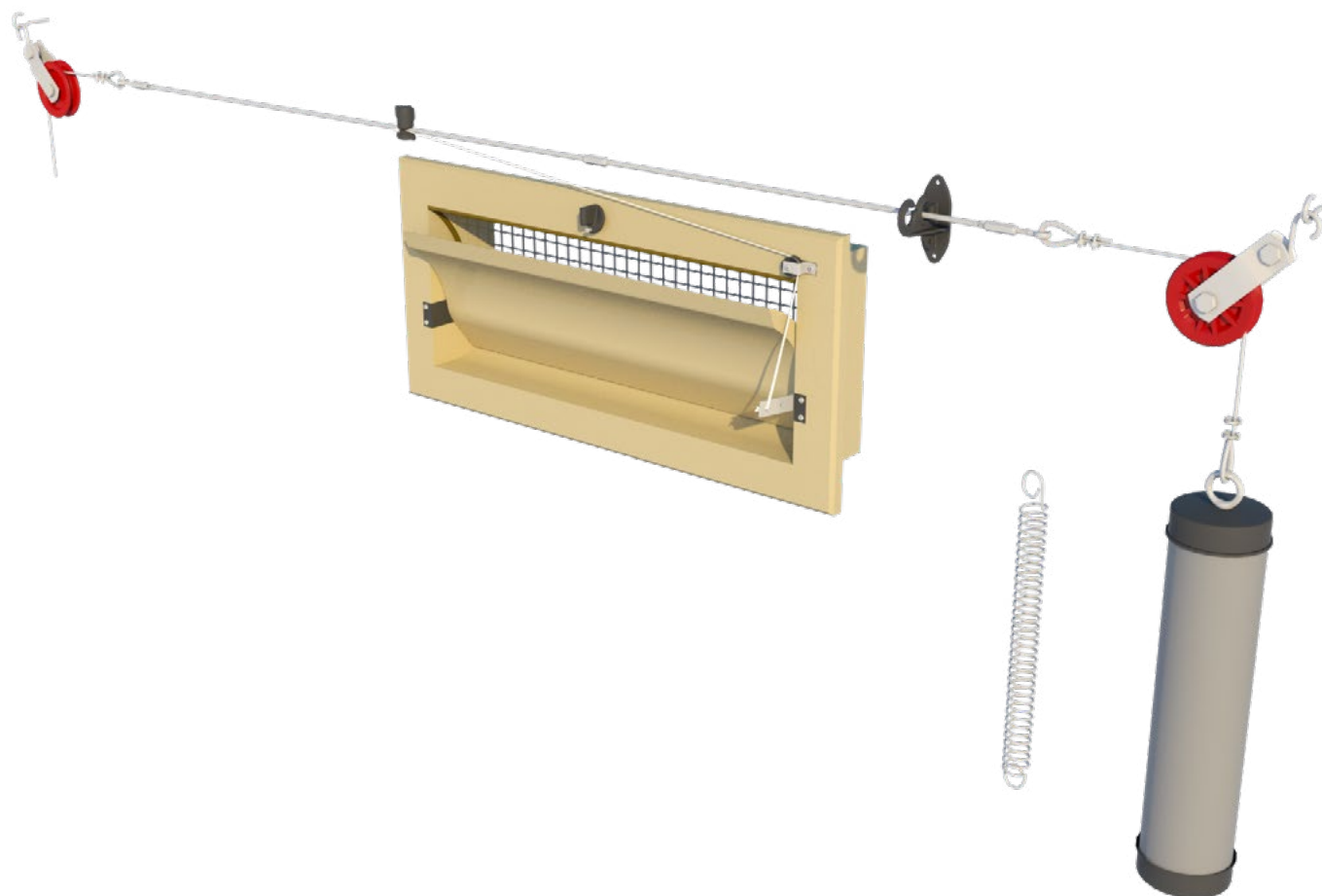

INFO

DATASHEET

ASSEMBLY

MOUNTING

WORKING

MAINTENANCE





145-VFG DATASHEET



CAPACITY

Model	m ³ /h @ 10 Pa	m ³ /h @ 20 Pa	m ³ /h @ 40 Pa
145-VFG	1450	2050	2900
	cfm @ 0.05 inH ₂ O	cfm @ 0.1 inH ₂ O	cfm @ 0.15 inH ₂ O
	954	1346	1648

INFORMATION

Run	11 cm / 4,3 inch
Force	2 kg / 19,6 Newton
Number / pallet (1,20 x 0,80 x 2,40 m / 47 x 31,5 x 94,5 inch)	52
Weight / per inlet	2 kg / 4.4 lbs
Volume / per box	26

OPTIONAL ACCESSORIES

TPI-101	Wire mesh galvanized
TPI-109	Wire mesh synthetic
TPI-205	Connection set
TPI-307	Closing catch + spring
TPI-702	Counter flange for inlets in 135/145-series

AIR FLOW

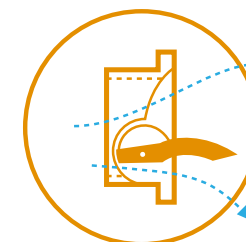
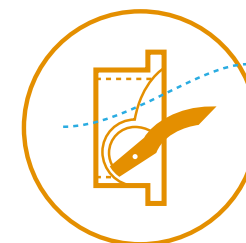

INFO

DATASHEET

ASSEMBLY

MOUNTING

WORKING

MAINTENANCE



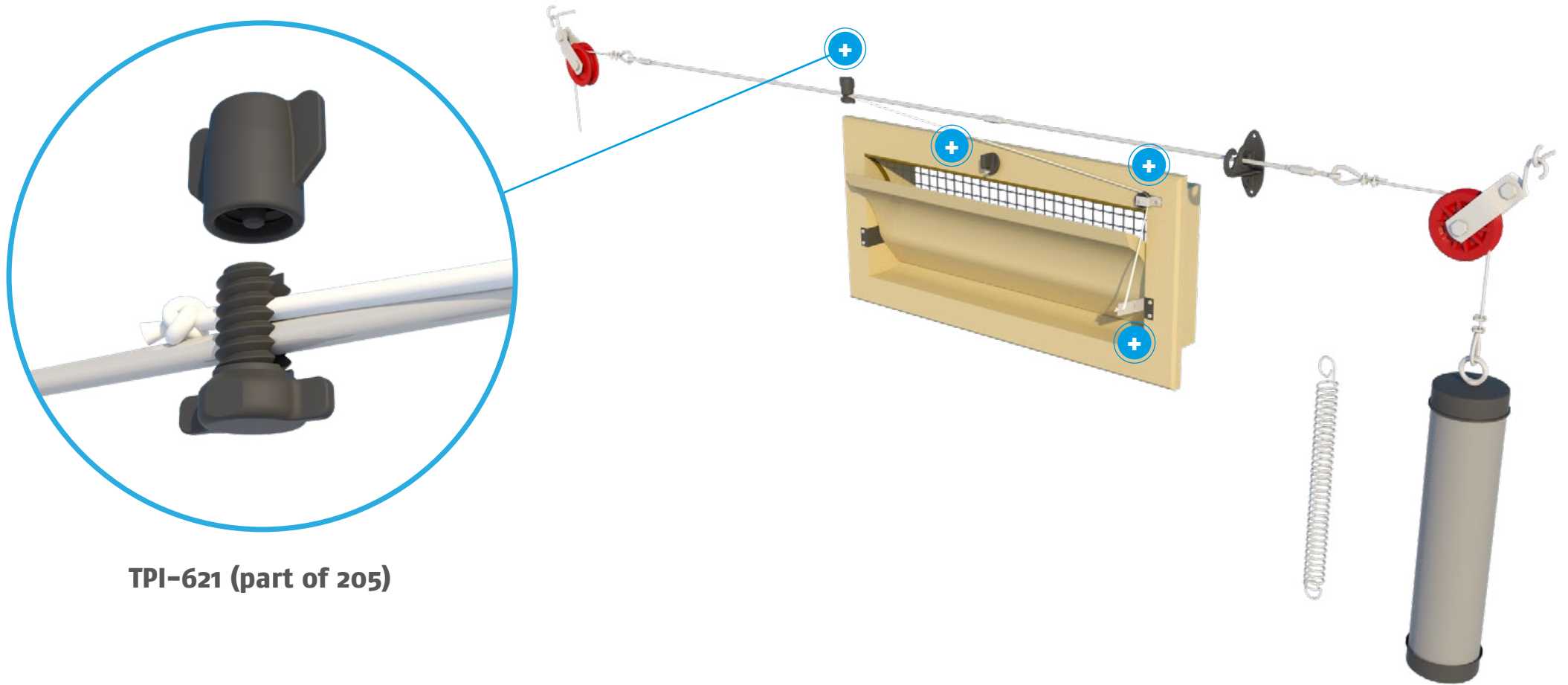

TPI-621 (part of 205)

[INFO](#)

[DATASHEET](#)

[ASSEMBLY](#)

[MOUNTING](#)

[WORKING](#)

[MAINTENANCE](#)



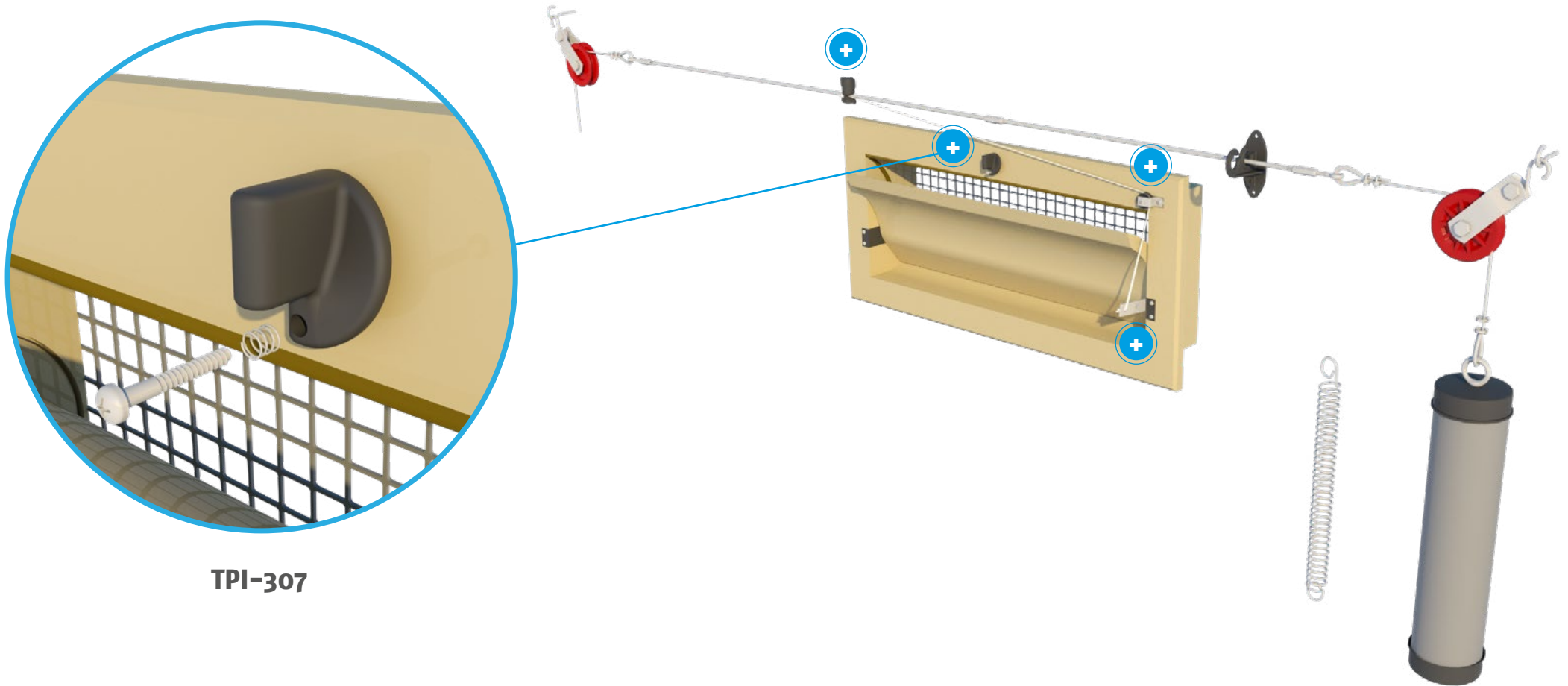

TPI-307

INFO

DATASHEET

ASSEMBLY

MOUNTING

WORKING

MAINTENANCE



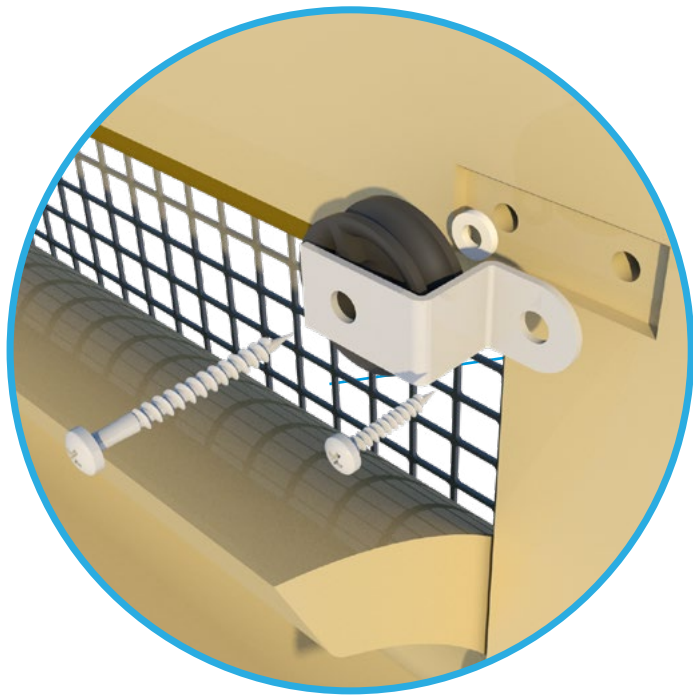

TPI-205

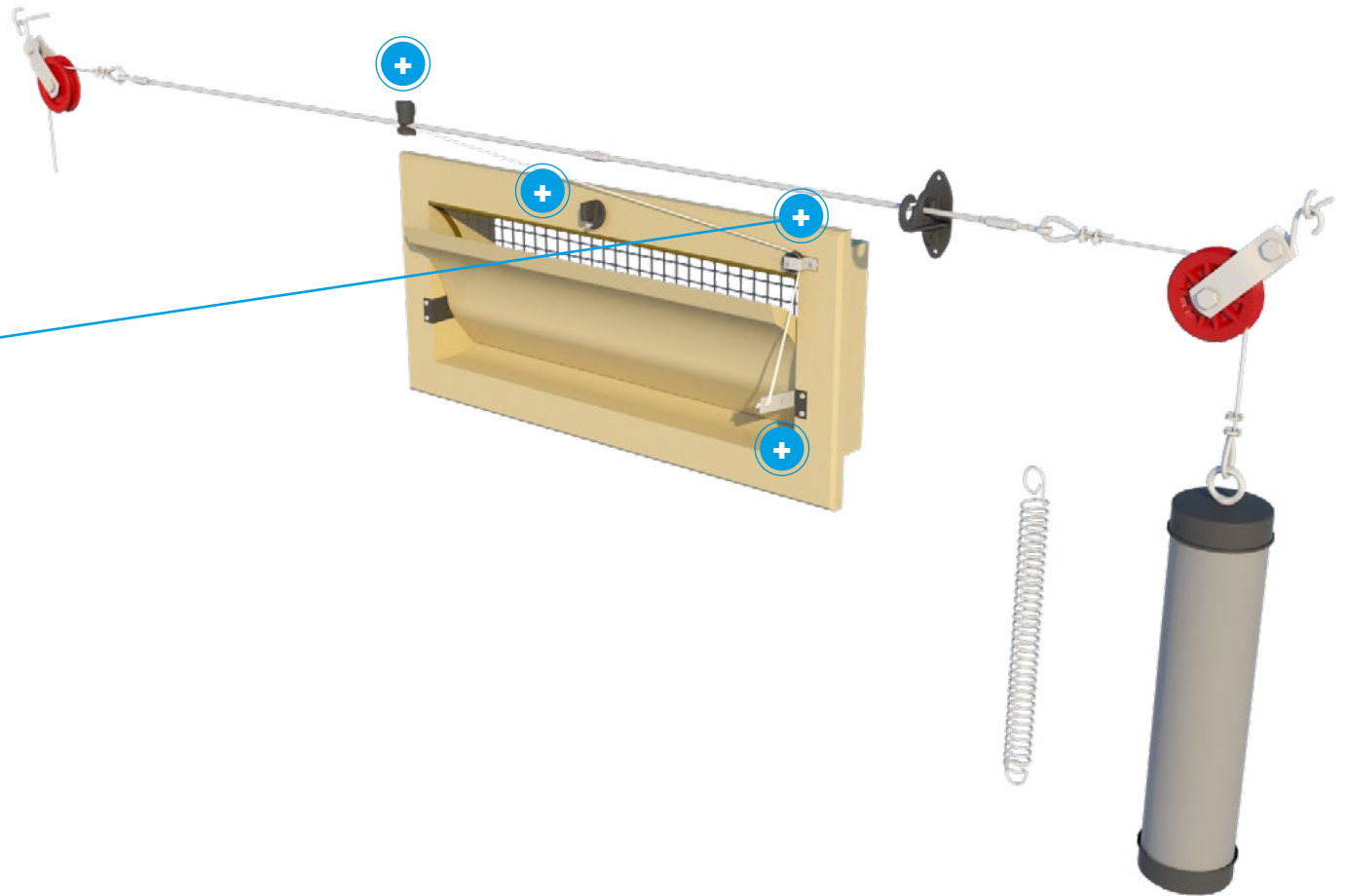

INFO

DATASHEET

ASSEMBLY

MOUNTING

WORKING

MAINTENANCE



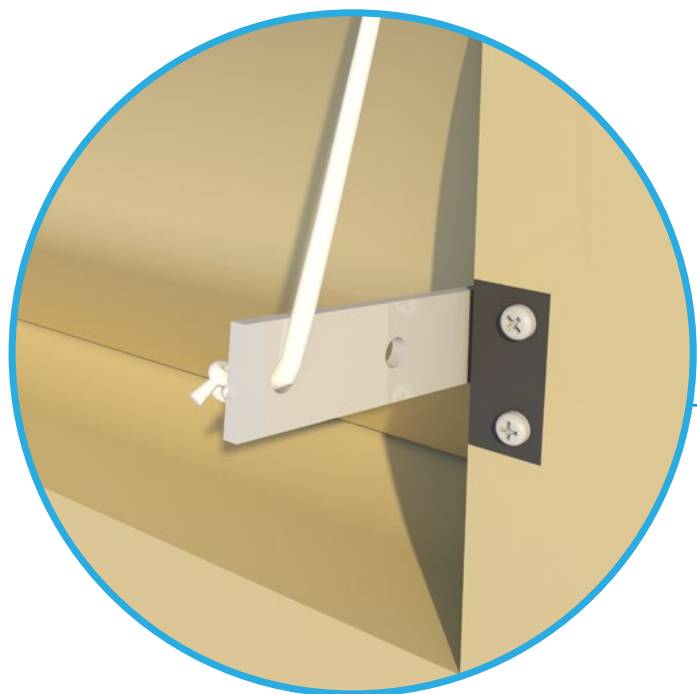

TPI-205 (Including TPI 621)

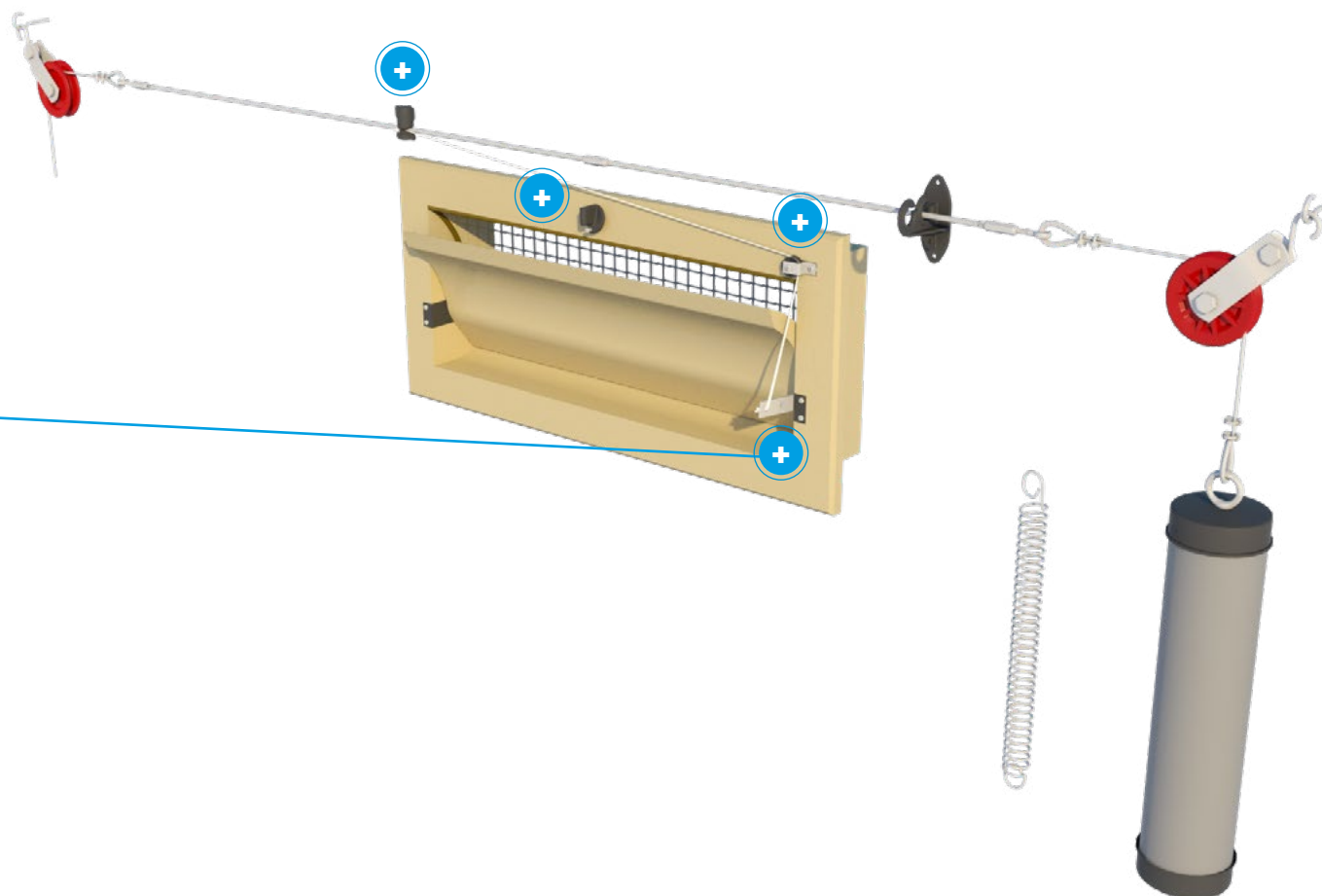

[INFO](#)

[DATASHEET](#)

[ASSEMBLY](#)

[MOUNTING](#)

[WORKING](#)

[MAINTENANCE](#)



All sizes are in cm and inches

Mounting points

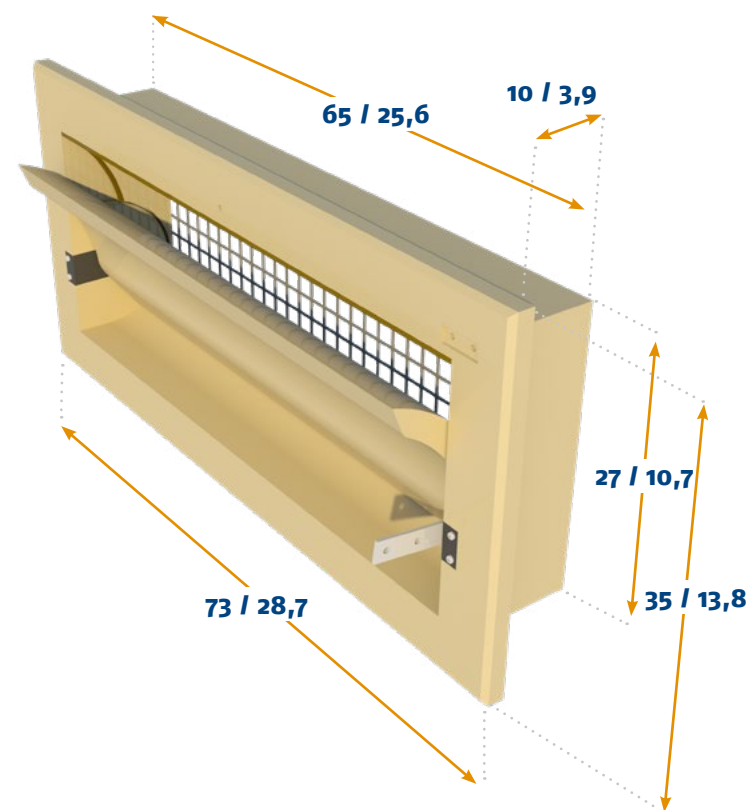
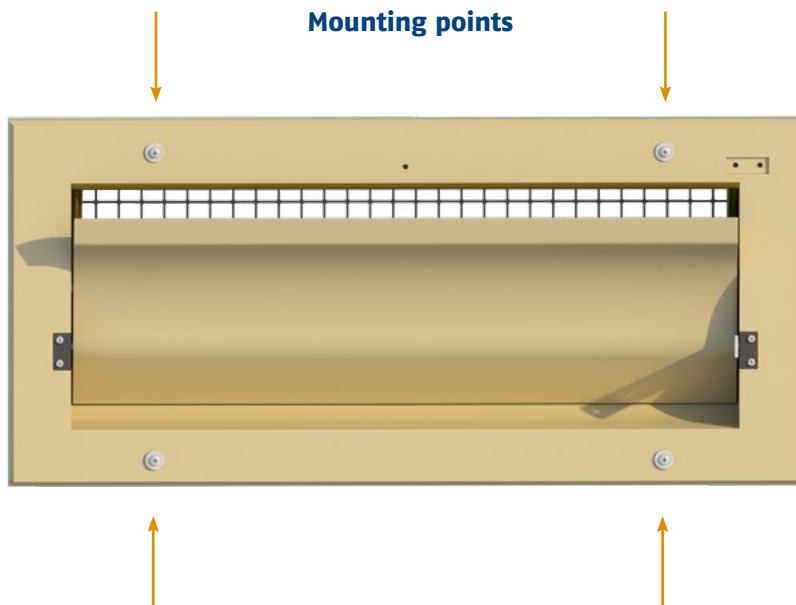

MOUNTING

Mounting type	Wall
Mounting hole size	67 cm / 26,4 inch x 29 cm / 11,5 inch

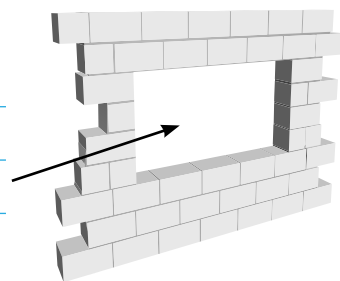

INFO

DATASHEET

ASSEMBLY

MOUNTING

WORKING

MAINTENANCE



AIR FLOW

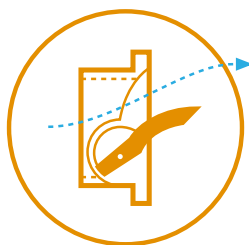

Middle hinged inlet

This middle hinged inlet is made to allow air to also flow underneath the inner flap after opening further than 35%. This helps to guide air downwards to the animals and provide a cooling effect during maximum ventilation.

Curved inner flap

This inlet is equipped with a curved inner flap. Curved flaps guide the air upwards during minimum ventilation, but also downwards after a certain point of opening. This is ideal for houses where air should be directed directly towards or over the animals during maximum ventilation.

Working with end-weights or springs

We offer two products which can be used to keep tension on the main cable. A PVC cylinder which can be filled with concrete or sand to act as end-weight, or a spring that holds tension on the cable.

Balanced set-up

When placing the motor winch or actuator we normally suggest to divide the inlets in two groups. It is preferable to place the winch or actuator in the middle to equally divide the forces on the main cable.

(see ventilation concepts page for an example)

Use of closing catches

The closing catch on the inlet can be used to permanently close inlets for example during pre-heating. The closing catches can also be used to close certain inlets while continuing to use others. In that case the used inlets can be opened a bit further. In colder climates this can help to offer better resistance to freezing effects.

Self-closing concept

This inlet is also available as a self-closing version. See the ventilation concepts page for more information.



INFO

DATASHEET

ASSEMBLY

MOUNTING

WORKING

MAINTENANCE



145-VFG-C

This inlet is suitable for almost all applications. With a middle hinged inner valve the air will be divided and also flows underneath the valve when it is opened over 35%. The inlet is controlled by means of a central plastic control arm. This inlet is executed with a curved inner valve so when it is opened for maximum ventilation air is also guide downwards to the animals.

(also available in self-closing version. See the ventilation concepts page for more information)

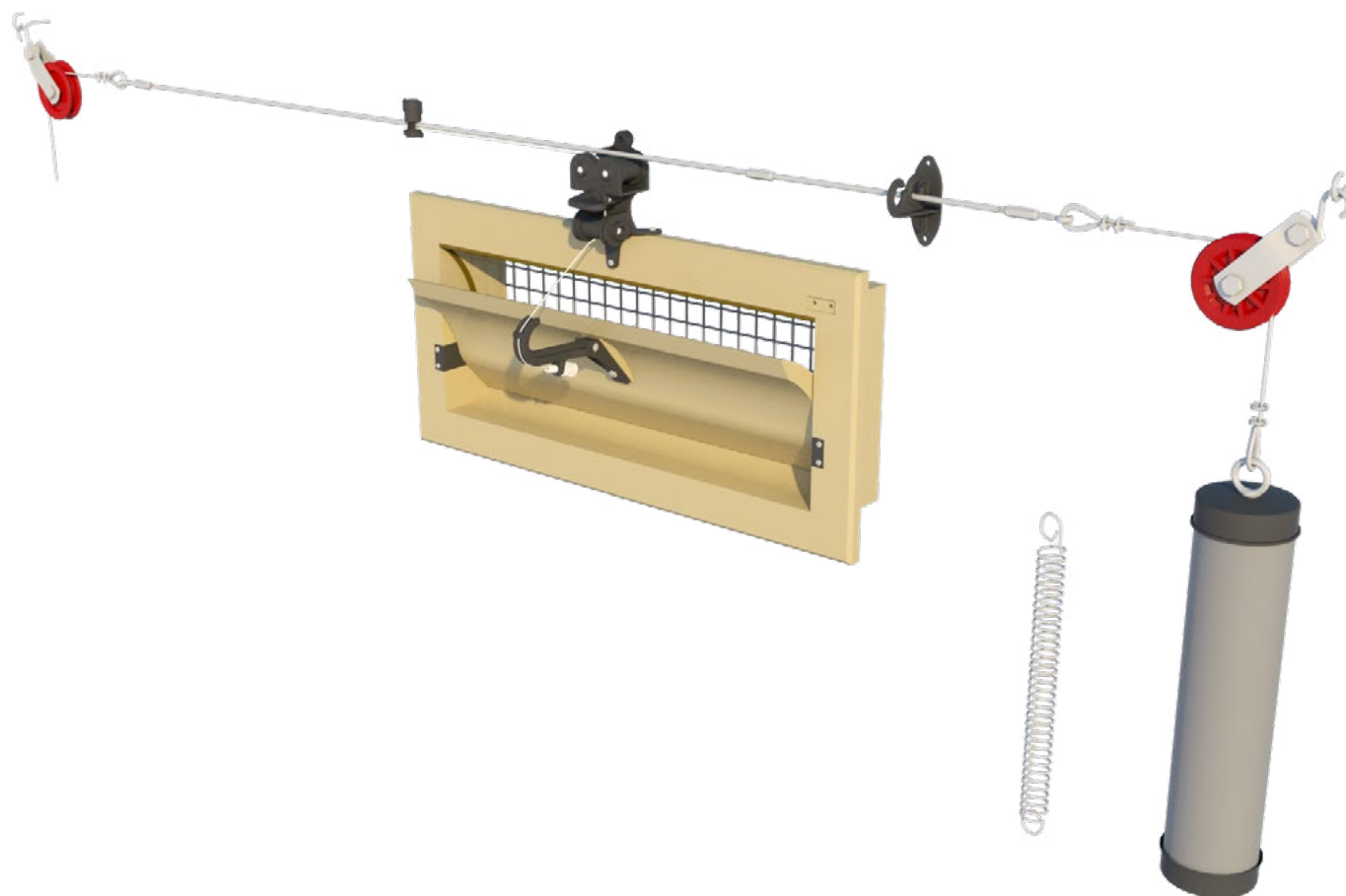

[INFO](#)

[DATASHEET](#)

[ASSEMBLY](#)

[MOUNTING](#)

[WORKING](#)

[MAINTENANCE](#)





145-VFG-C DATASHEET



CAPACITY

Model	m ³ /h @ 10 Pa	m ³ /h @ 20 Pa	m ³ /h @ 40 Pa
145-VFG-C	1450	2050	2900
	cfm @ 0.05 inH ₂ O	cfm @ 0.1 inH ₂ O	cfm @ 0.15 inH ₂ O
	954	1346	1648

INFORMATION

Run	29 cm / 11.4 inch
Force	1 kg / 9.8 Newton
Number / pallet (1,20 x 0.80 x 2,40m / 47 x 31,5 x 94,5 inch)	52
Weight / per inlet	2,0 kg / 4,4 Lbs
Volume / per box	26
Arm position	2

OPTIONAL ACCESSORIES

TPI-101	Wire mesh galvanized
TPI-109	Wire mesh synthetic
TPI-204c	Connection set
TPI-423	Pulley Unit + Closing Catch
TPI-702	Counter flange for inlets in 135/145-series

AIR FLOW

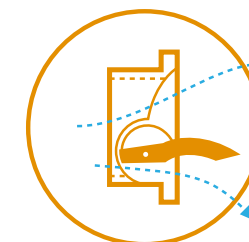
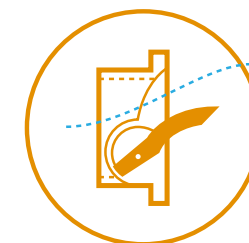

INFO

DATASHEET

ASSEMBLY

MOUNTING

WORKING

MAINTENANCE



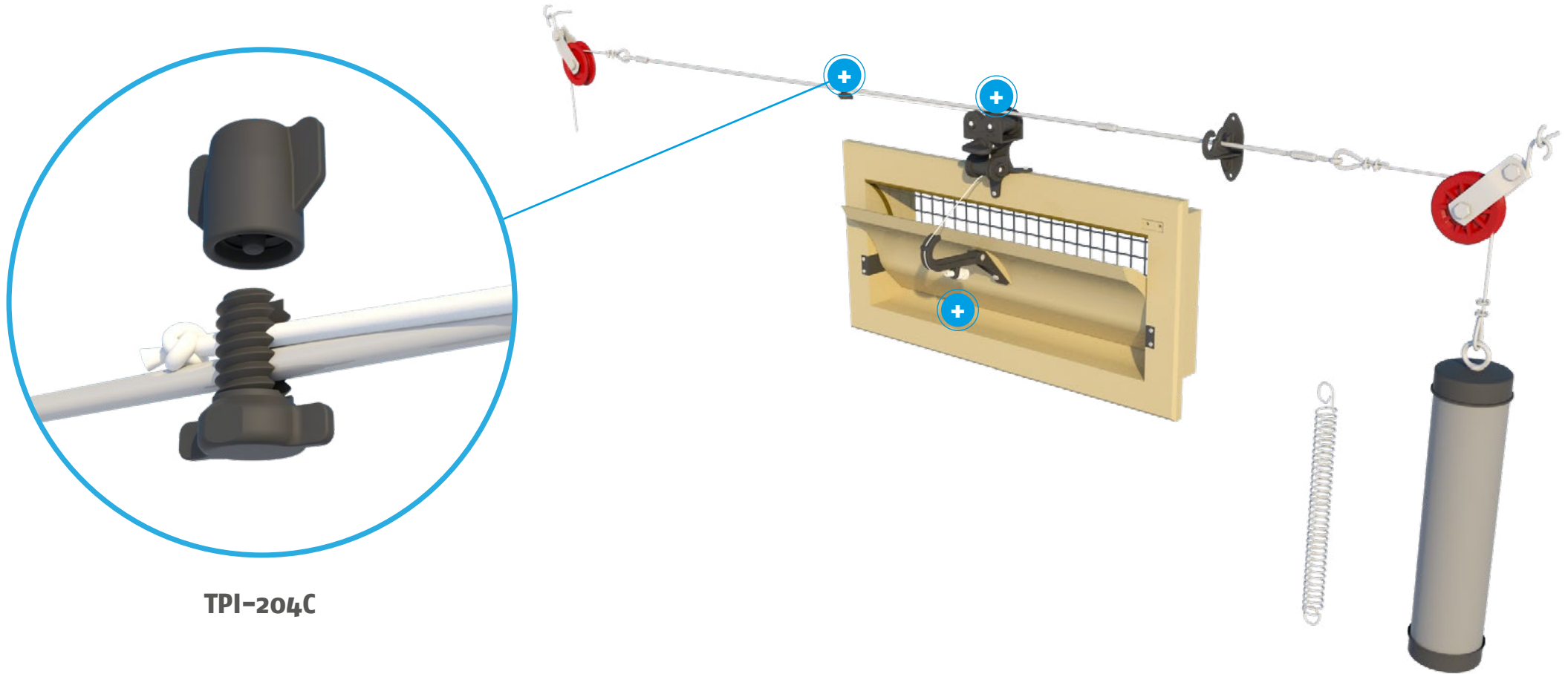

TPI-204C

INFO

DATASHEET

ASSEMBLY

MOUNTING

WORKING

MAINTENANCE



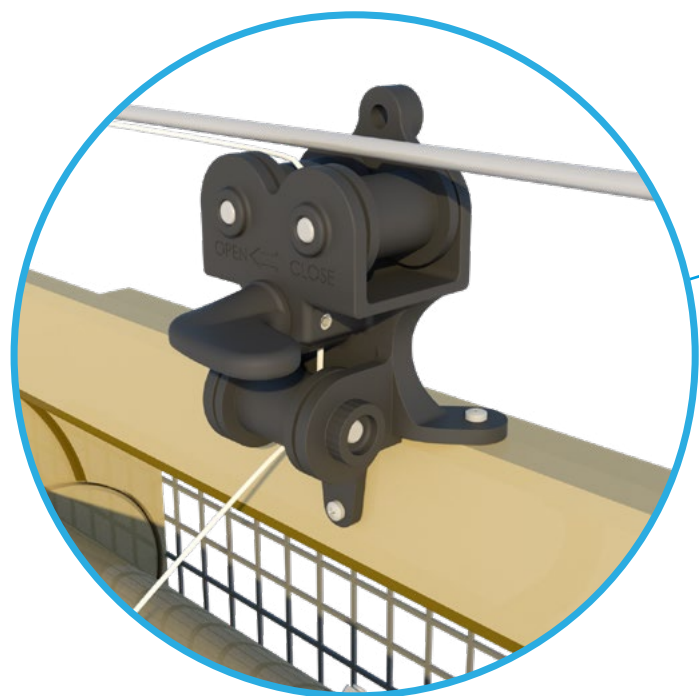

TPI-423

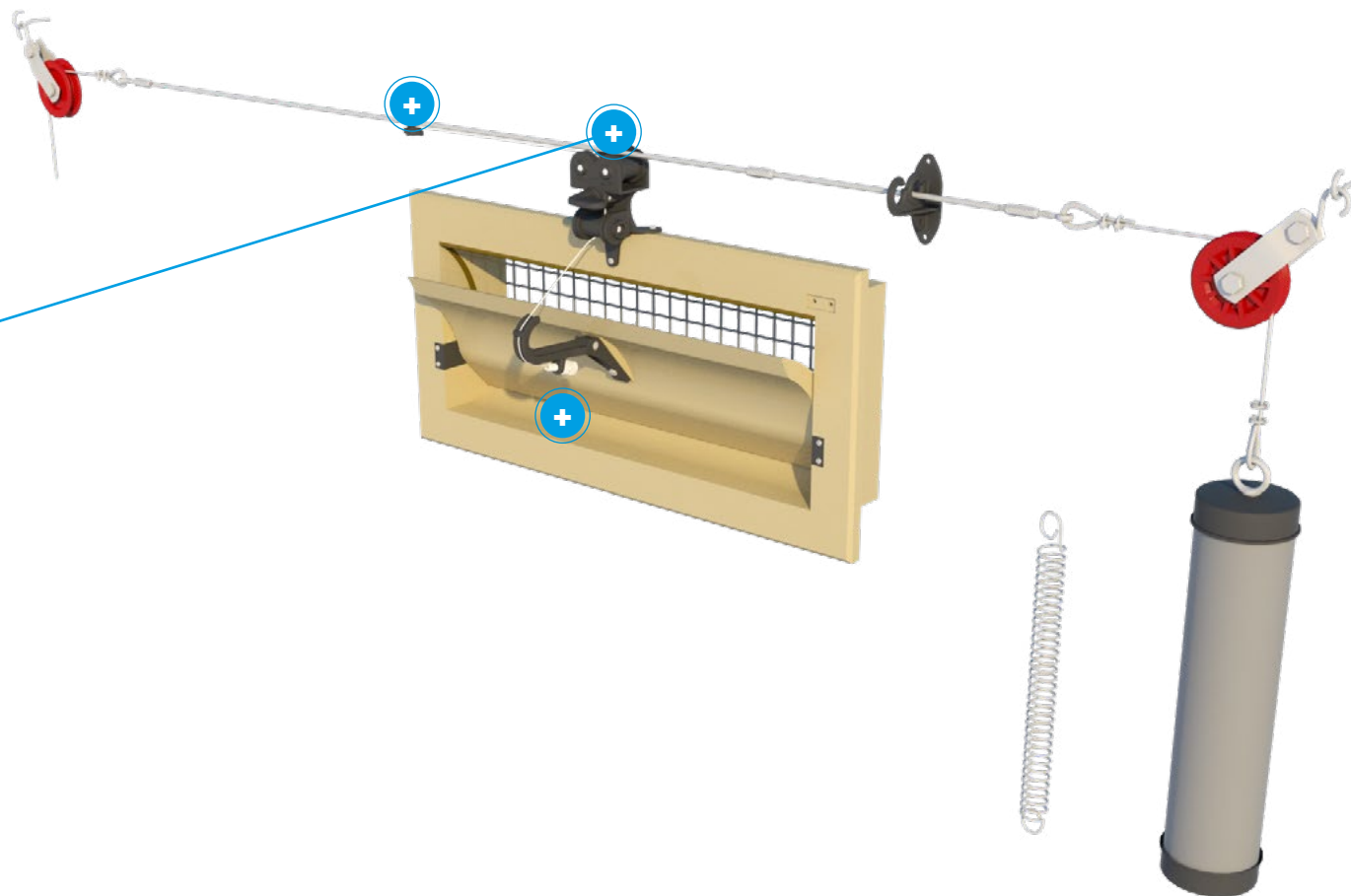

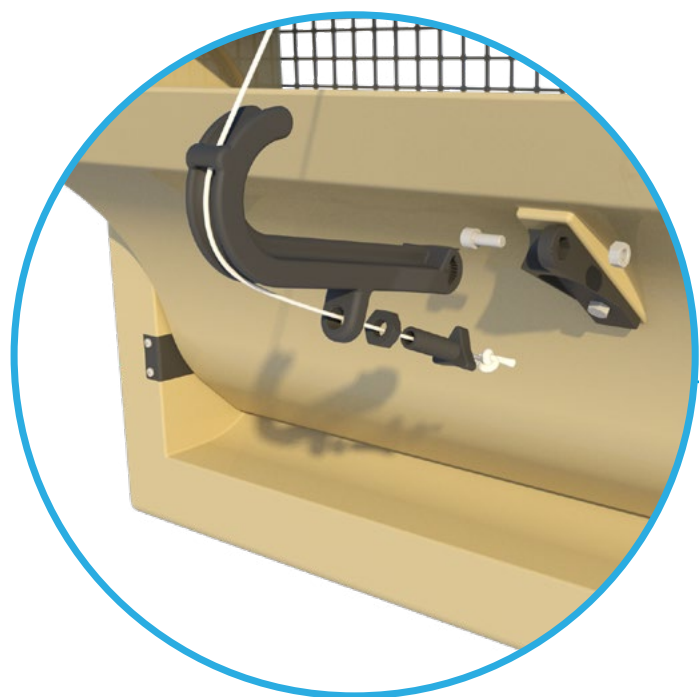

TPI-208 Arm angle position : 2

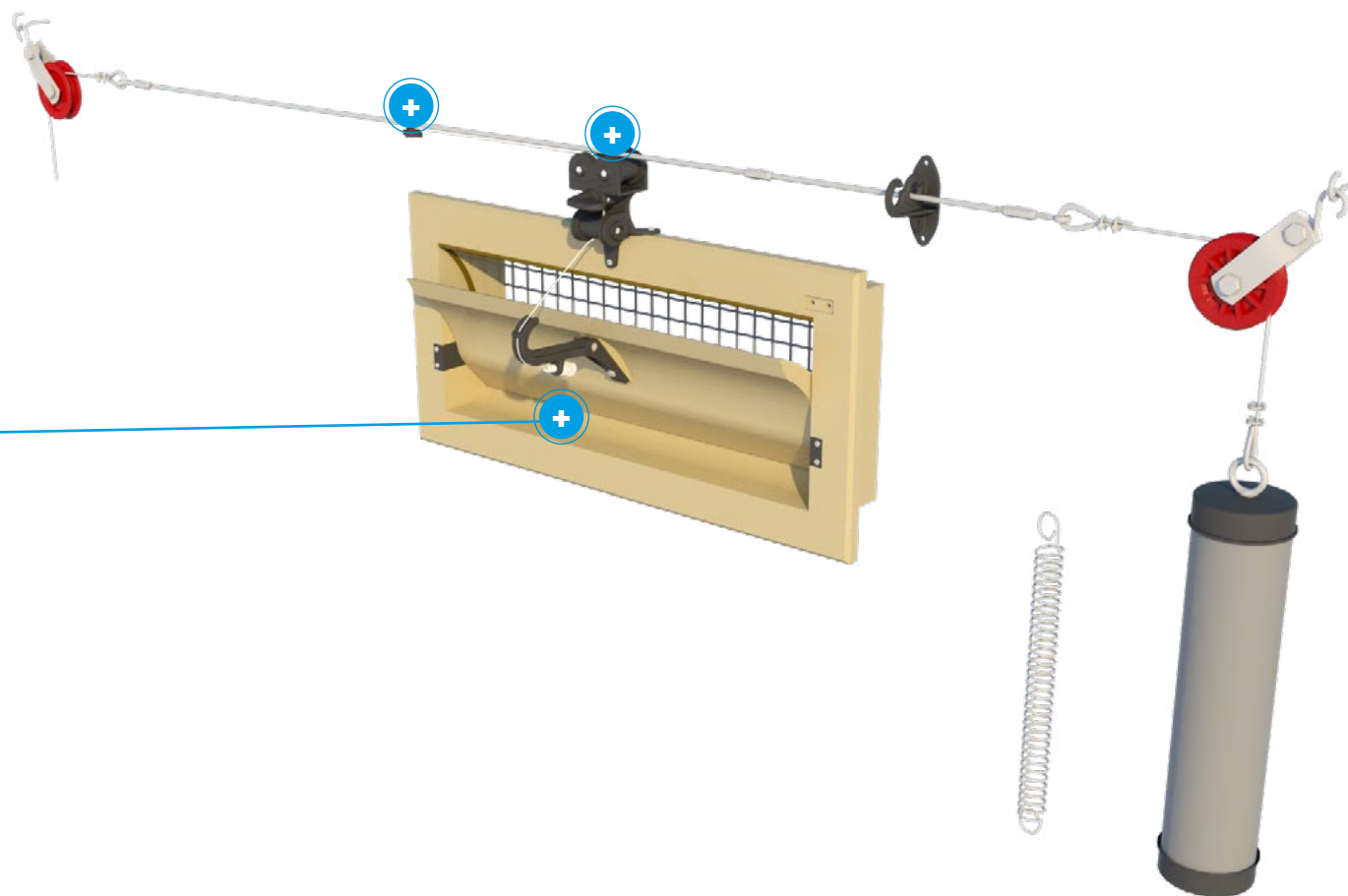

All sizes are in cm and inches

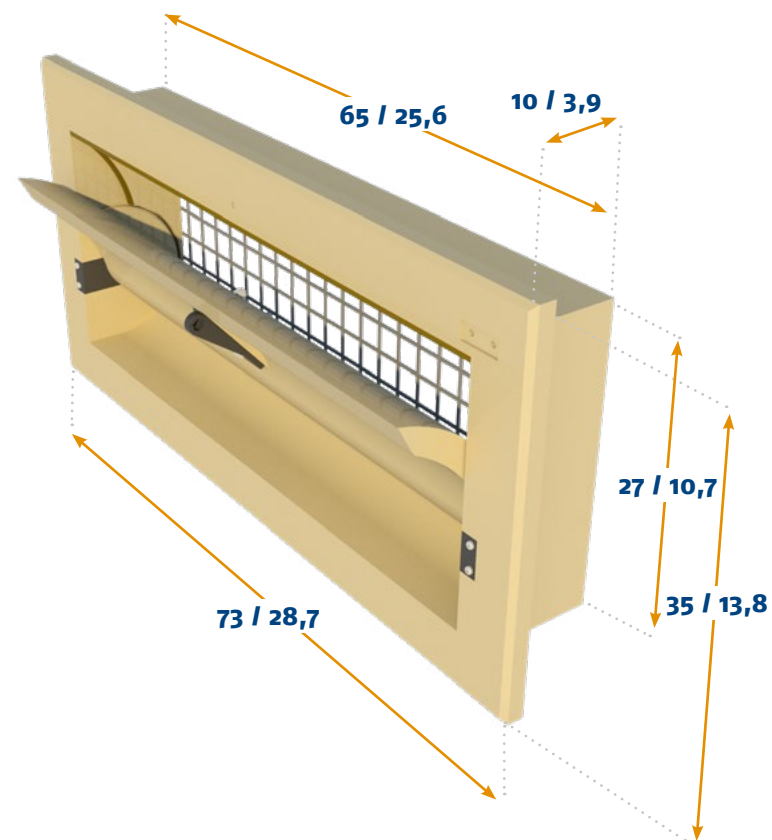
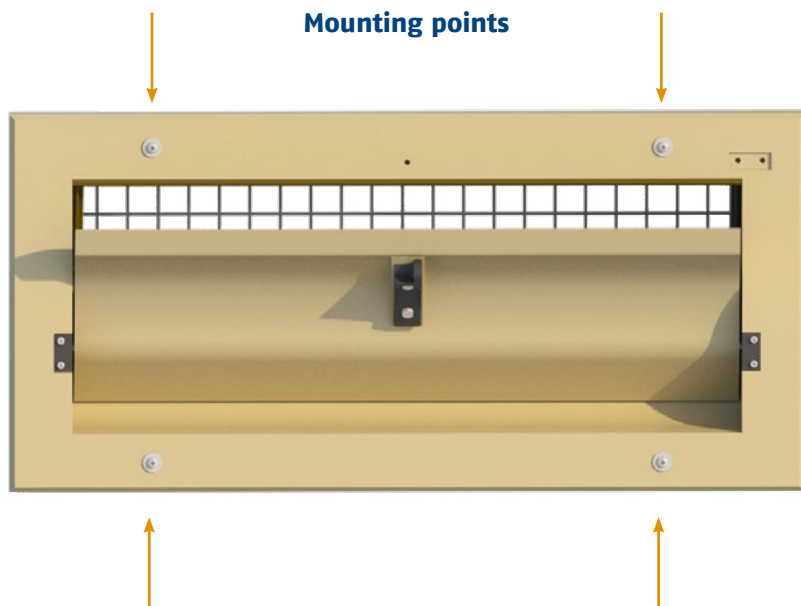

MOUNTING

Mounting type	Wall
Mounting hole size	67 cm / 26,4 inch x 29 cm / 11,5 inch

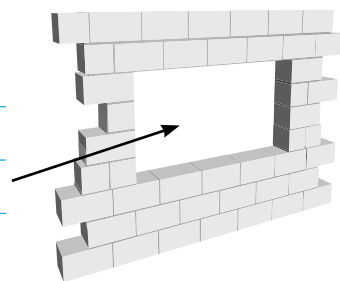

INFO

DATASHEET

ASSEMBLY

MOUNTING

WORKING

MAINTENANCE



AIR FLOW

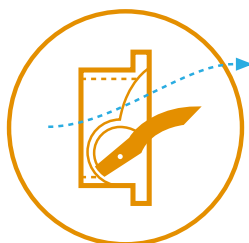

Middle hinged inlet

This middle hinged inlet is made to allow air to also flow underneath the inner flap after opening further then 35%. This helps to guide air downwards to the animals and provide a cooling effect during maximum ventilation.

Curved inner flap

This inlet is equipped with a curved inner flap. Curved flaps guide the air upwards during minimum ventilation, but also downwards after a certain point of opening. This is ideal for houses where air should be directed directly towards or over the animals during maximum ventilation.

Making adjustments

By using the nylon bolt and nut small adjustments can be made to make sure all inlets are closing and opening correctly. The nylon cable clamp and cord can also be used to make small adjustments.

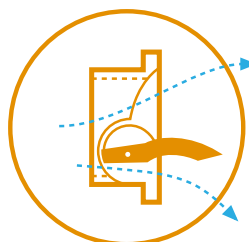

Working with end-weights or springs

We offer two products which can be used to keep tension on the main cable. A PVC cylinder which can be filled with concrete or sand to act as end-weight, or a spring that holds tension on the cable.

Balanced set-up

When placing the motor winch or actuator we normally suggest to divide the inlets in two groups. It is preferable to place the winch or actuator in the middle to equally divide the forces on the main cable.

(see ventilation concepts page for an example)

Use of closing catches

The closing catch on the inlet can be used to permanently close inlets for example during pre-heating. The closing catches can also be used to close certain inlets while continuing to use others. In that case the used inlets can be opened a bit further. In colder climates this can help to offer better resistance to freezing effects.

Self-closing concept

This inlet is also available as a self-closing version. See the ventilation concepts page for more information.

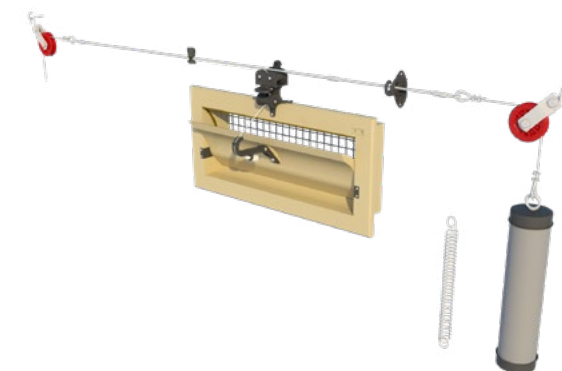

INFO

DATASHEET

ASSEMBLY

MOUNTING

WORKING

MAINTENANCE



145-VFR

This inlet is suitable for almost all applications. With a middle hinged inner valve the air will be divided and also flows underneath the valve when it is opened over 35%. The inlet is controlled by means of a stainless steel side arm. This inlet is executed with a straight inner valve so even when it is opened for maximum ventilation air is not guided downwards to the animals.

(also available in self-closing version. See the ventilation concepts page for more information)

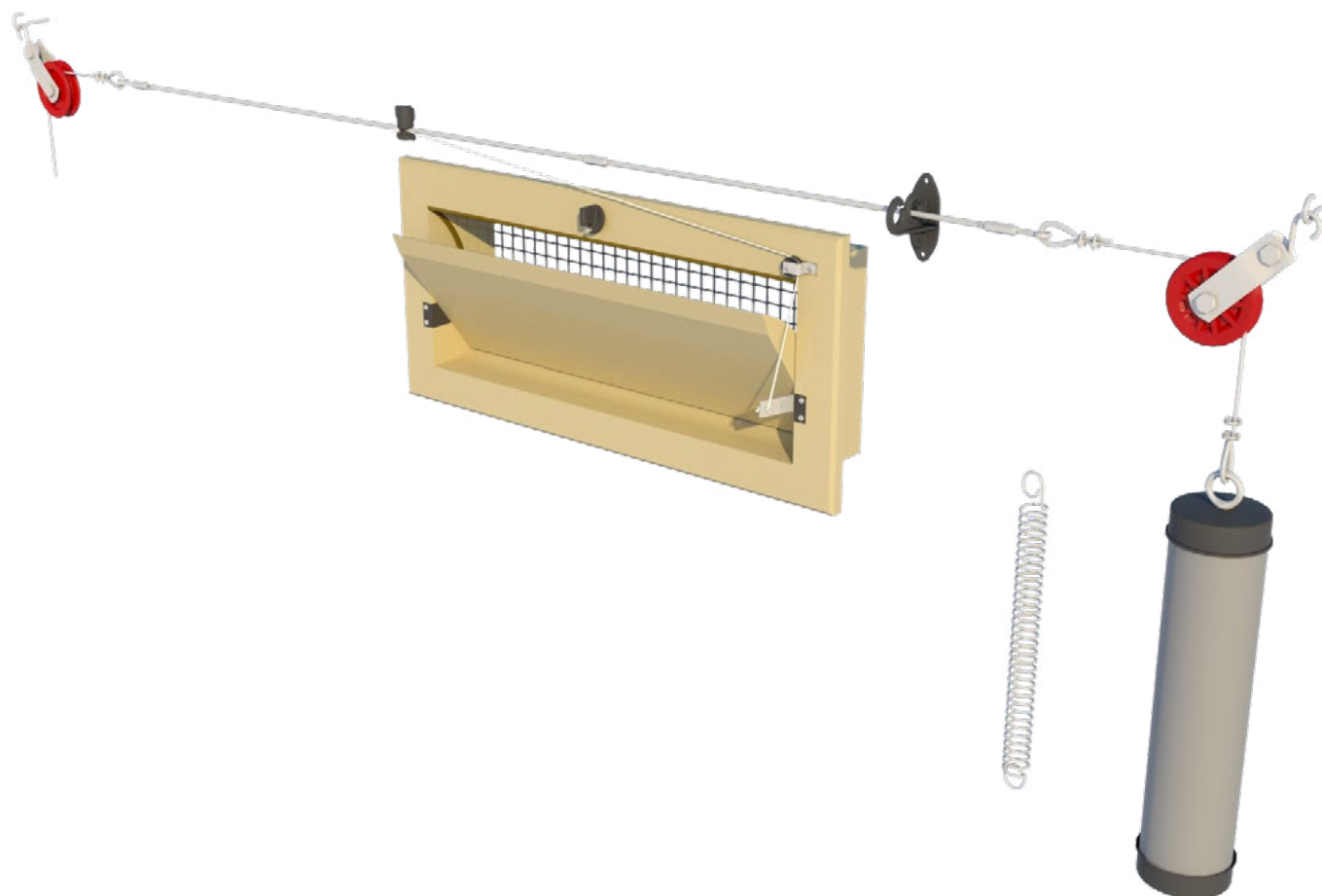

INFO

DATASHEET

ASSEMBLY

MOUNTING

WORKING

MAINTENANCE





145-VFR DATASHEET



CAPACITY

Model	m ³ /h @ 10 Pa	m ³ /h @ 20 Pa	m ³ /h @ 40 Pa
145-VFR	1450	2050	2900
	cfm @ 0.05 inH ₂ O	cfm @ 0.1 inH ₂ O	cfm @ 0.15 inH ₂ O
	954	1346	1648

INFORMATION

Run	11 cm / 4.3 inch
Force	2 kg / 19.6 Newton
Number / pallet (1,20 x 0,80 x 2,40m / 47 x 31,5 x 94,5inch)	52
Weight / per inlet	2,0 kg / 4.4 lbs
Volume / per box	26

OPTIONAL ACCESSORIES

TPI-101	Wire mesh galvanized
TPI-109	Wire mesh synthetic
TPI-205	Connection set
TPI-307	Closing catch + spring
TPI-702	Counter flange for inlets in 135/145-series

AIR FLOW

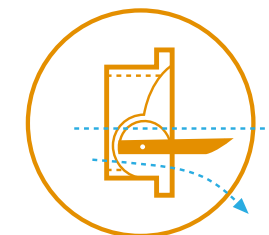
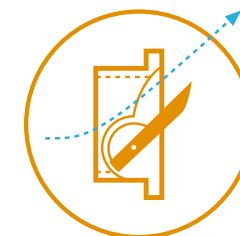
[INFO](#)[DATASHEET](#)[ASSEMBLY](#)[MOUNTING](#)[WORKING](#)[MAINTENANCE](#)

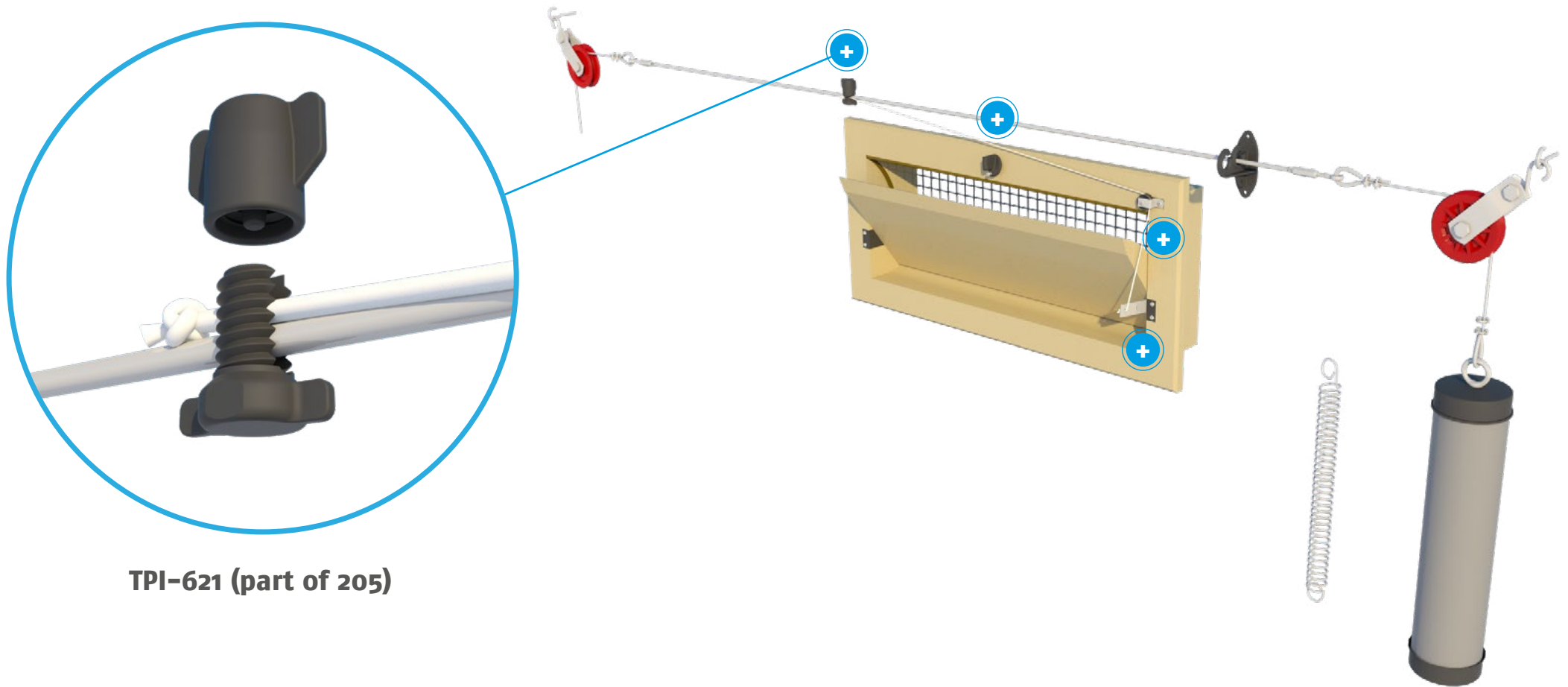

TPI-621 (part of 205)

INFO

DATASHEET

ASSEMBLY

MOUNTING

WORKING

MAINTENANCE





TPI-307

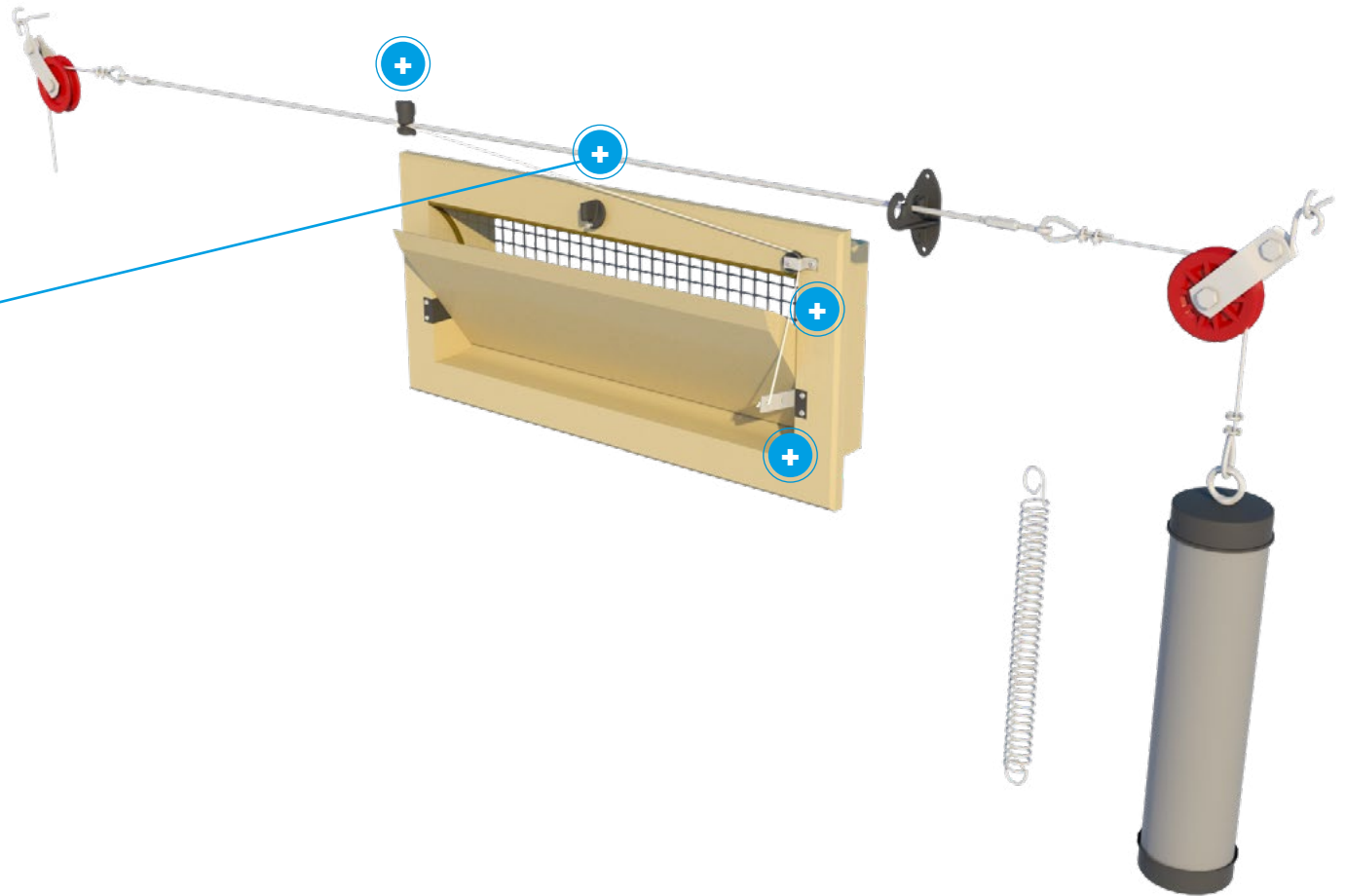

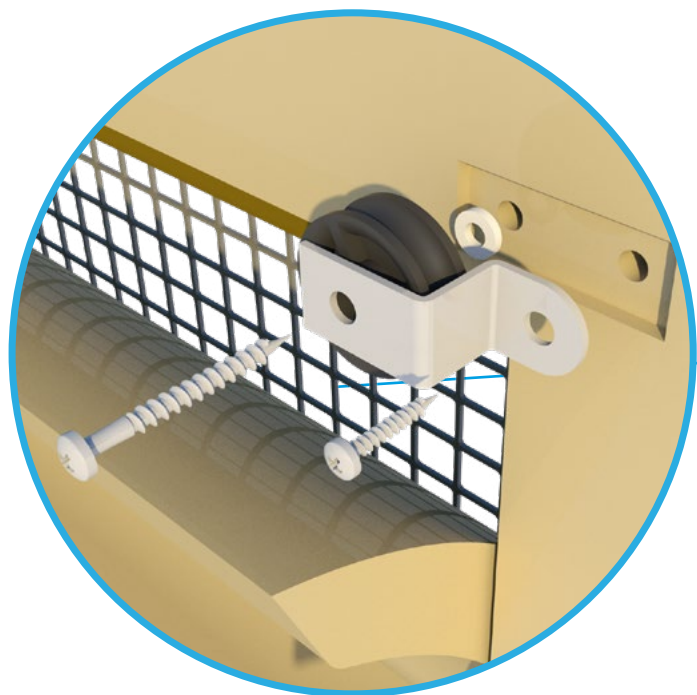

TPI-205

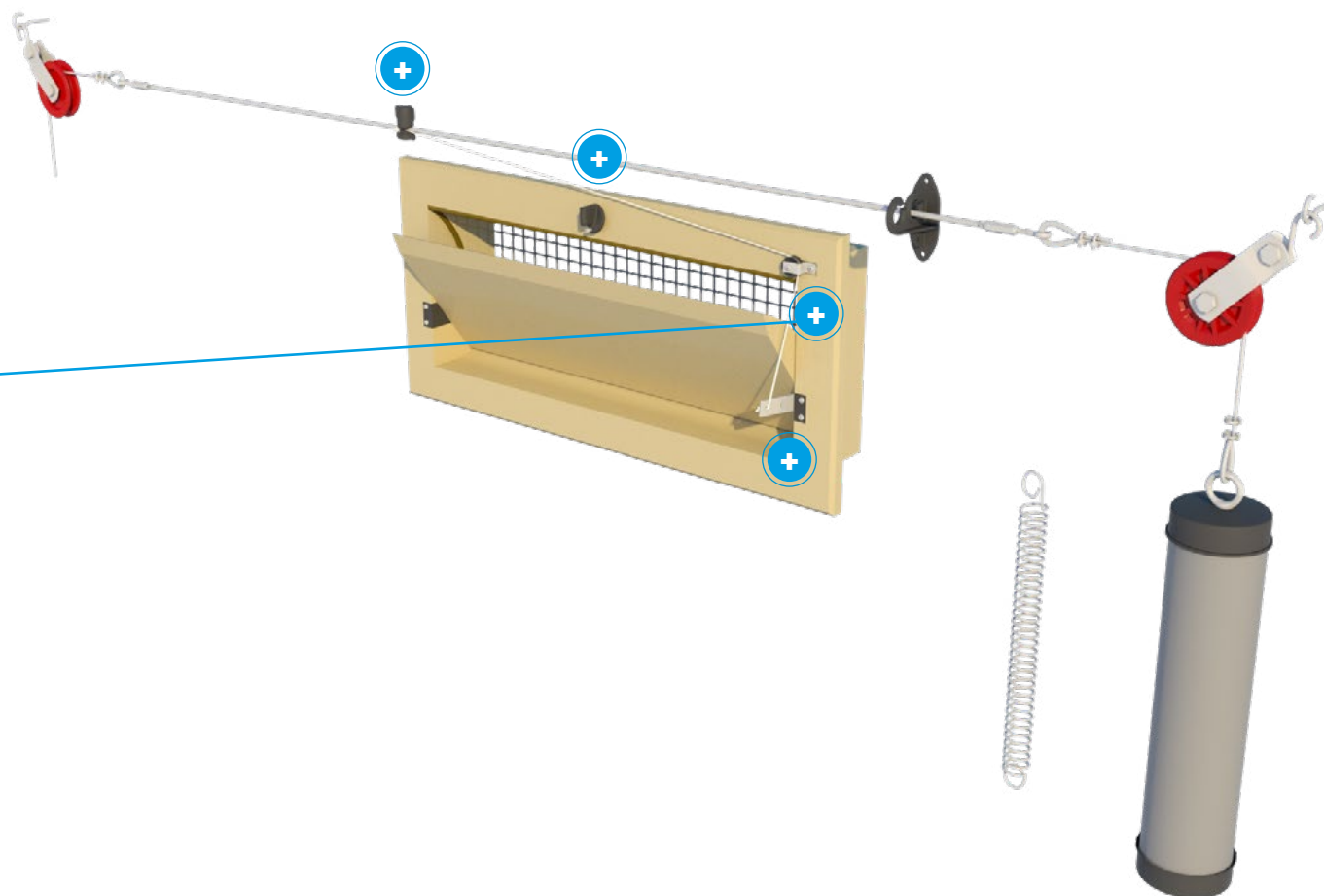

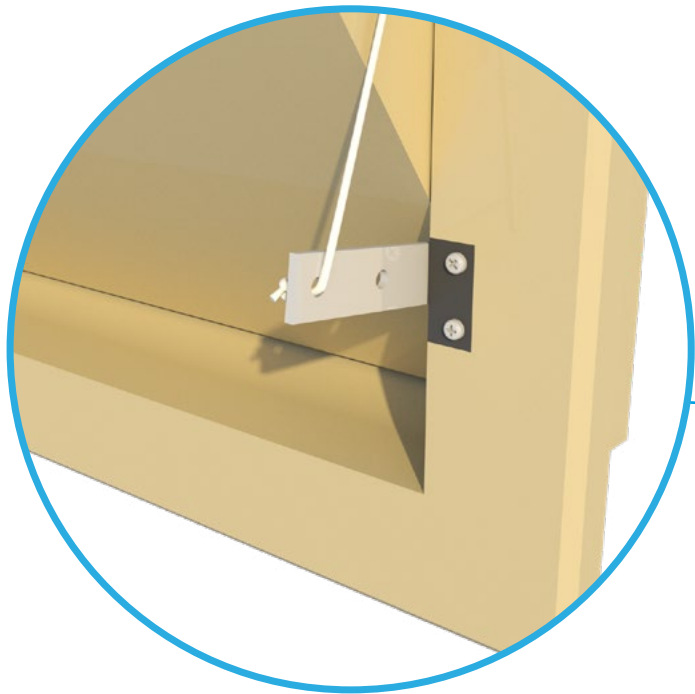

TPI-205 (Including TPI 621)

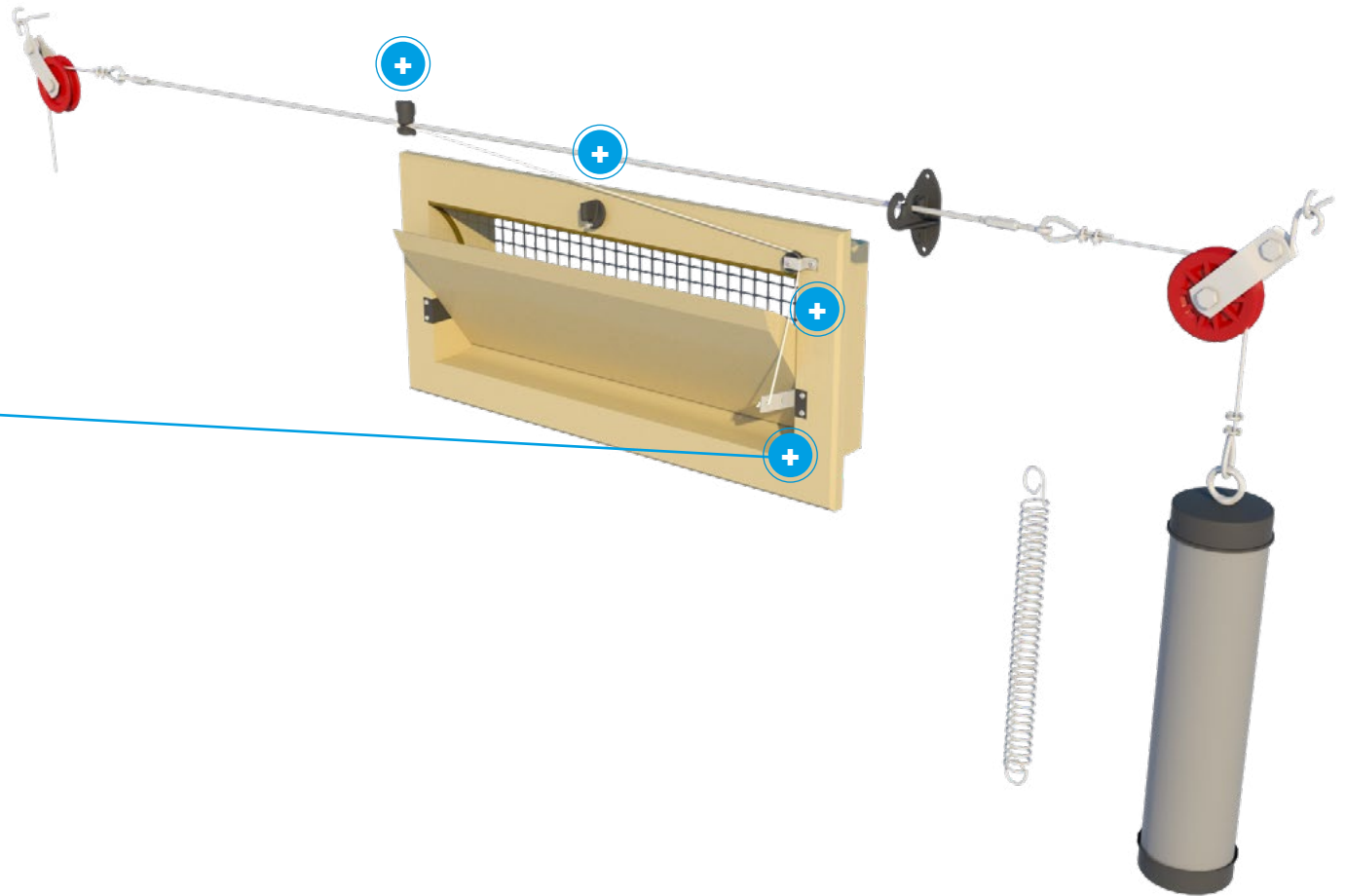

[INFO](#)

[DATASHEET](#)

[ASSEMBLY](#)

[MOUNTING](#)

[WORKING](#)

[MAINTENANCE](#)



All sizes are in cm and inches

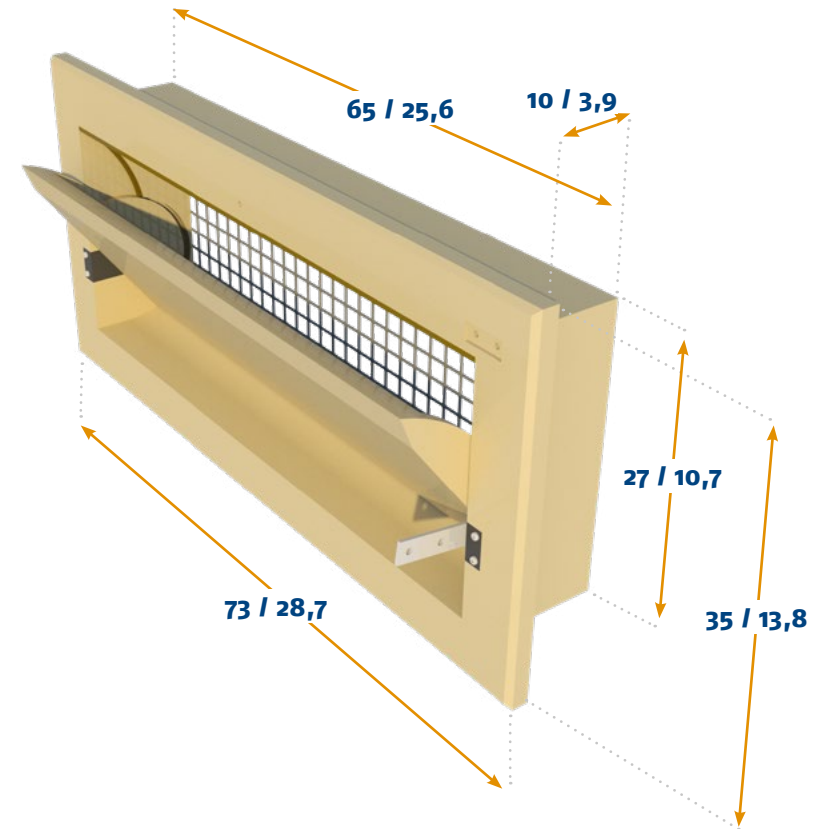
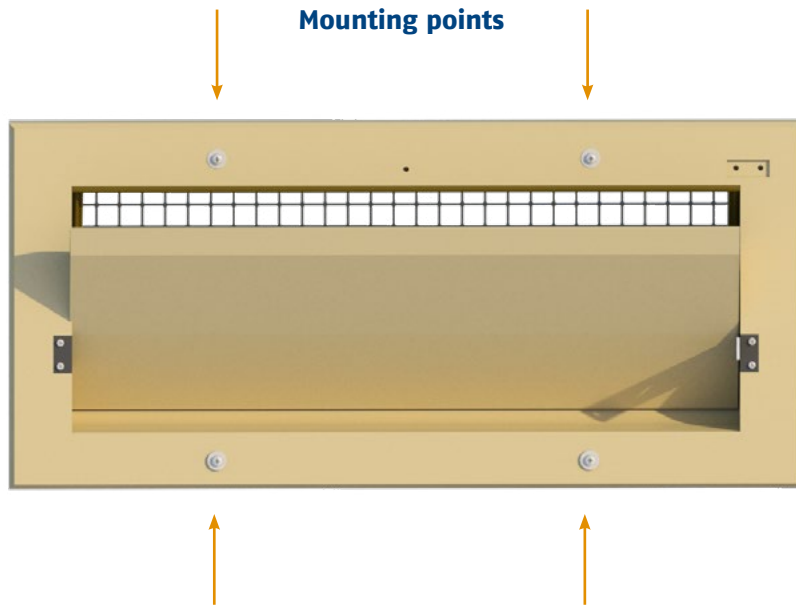

MOUNTING

Mounting type	Wall
Max. hole size in wall	67 cm / 26,4 inch x 29 cm / 11,5 inch

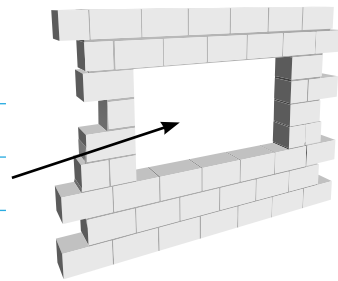

[INFO](#)

[DATASHEET](#)

[ASSEMBLY](#)

[MOUNTING](#)

[WORKING](#)

[MAINTENANCE](#)



AIR FLOW

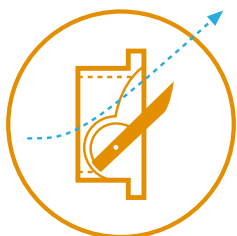

Middle hinged inlet

This middle hinged inlet is made to allow air to also flow underneath the inner flap after opening further than 35%. This helps to guide air downwards to the animals and provide a cooling effect during maximum ventilation.

Straight inner flap

This inlet is equipped with a straight inner flap. Straight flaps guide air in a straight upwards or horizontal direction, never downwards. This is ideal for houses where air should not be directed directly towards or over the animals during maximum ventilation.

Working with end-weights or springs

We offer two products which can be used to keep tension on the main cable. A PVC cylinder which can be filled with concrete or sand to act as end-weight, or a spring that holds tension on the cable.

Balanced set-up

When placing the motor winch or actuator we normally suggest to divide the inlets in two groups. It is preferable to place the winch or actuator in the middle to equally divide the forces on the main cable.

(see ventilation concepts page for an example)

Use of closing catches

The closing catch on the inlet can be used to permanently close inlets for example during pre-heating. The closing catches can also be used to close certain inlets while continuing to use others. In that case the used inlets can be opened a bit further. In colder climates this can help to offer better resistance to freezing effects.

Self-closing concept

This inlet is also available as a self-closing version. See the ventilation concepts page for more information.

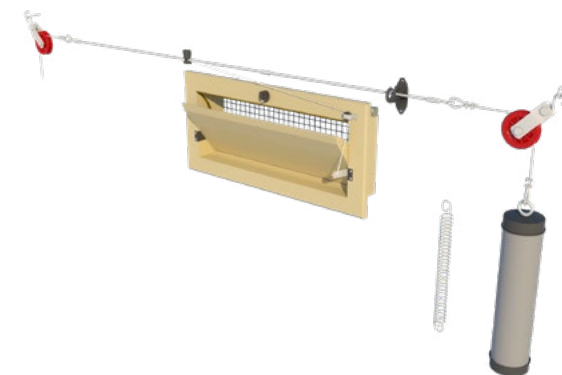

INFO

DATASHEET

ASSEMBLY

MOUNTING

WORKING

MAINTENANCE



145-VFR-C

This inlet is suitable for almost all applications. With a middle hinged inner valve the air will be divided and also flows underneath the valve when it is opened over 35%. The inlet is controlled by means of a central plastic control arm. This inlet is executed with a straight inner valve so even when it is opened for maximum ventilation air is not guided downwards to the animals.

(also available in self-closing version. See the ventilation concepts page for more information)

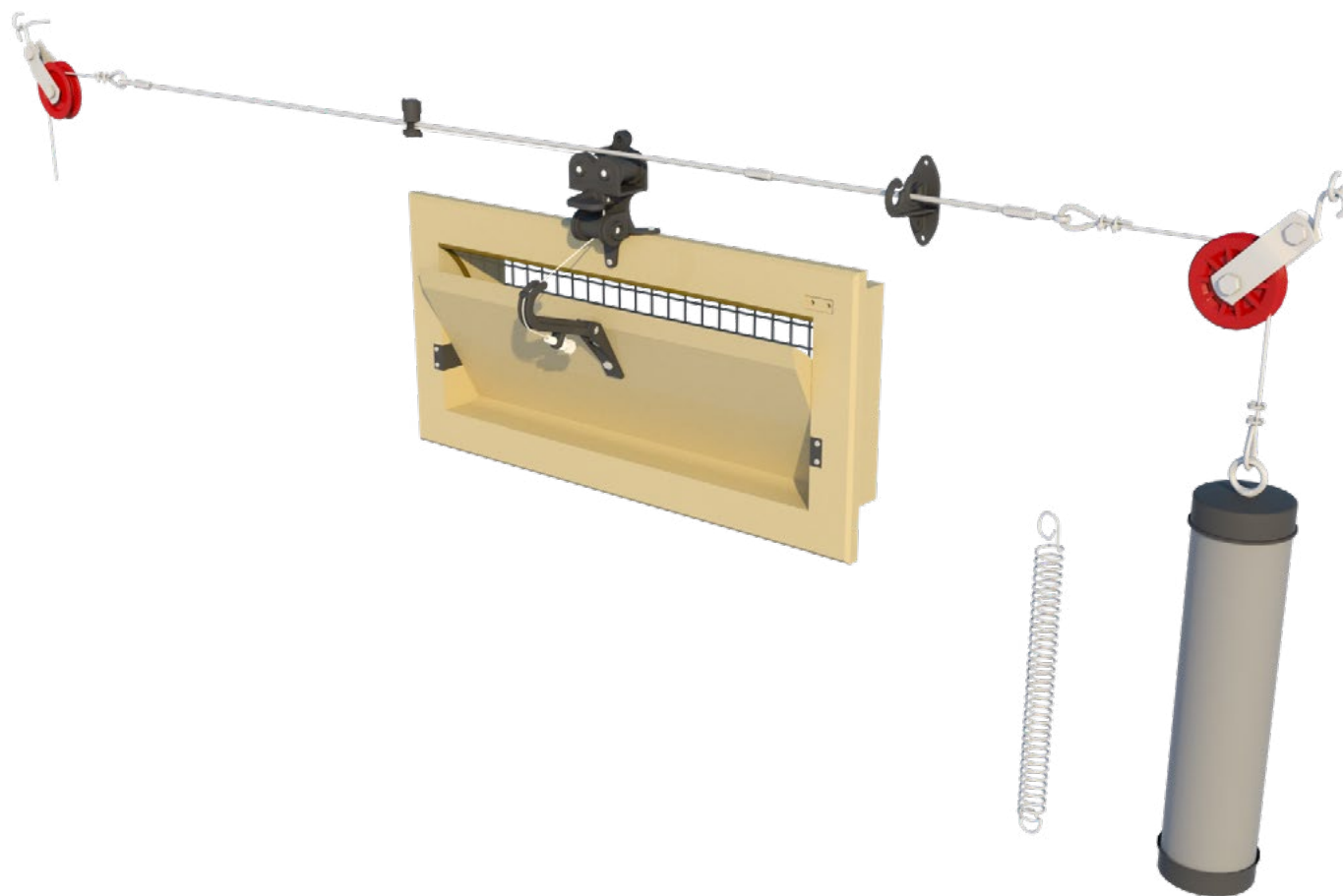

INFO

DATASHEET

ASSEMBLY

MOUNTING

WORKING

MAINTENANCE





145-VFR-C DATASHEET



CAPACITY

Model	m ³ /h @ 10 Pa	m ³ /h @ 20 Pa	m ³ /h @ 40 Pa
145-VFR-C	1450	2050	2900
	cfm @ 0.05 inH ₂ O	cfm @ 0.1 inH ₂ O	cfm @ 0.15 inH ₂ O
	954	1346	1648

INFORMATION

Run	27 cm / 10.6 inch
Force	1 kg / 9.8 Newton
Number / pallet (1,20 x 0,80 x 2,40m / 47 x 31,5 x 94,5inch)	52
Weight / per inlet	2,0 kg / 4.4 lbs
Volume / per box	26
Arm position	2

OPTIONAL ACCESSORIES

TPI-101	Wire mesh galvanized
TPI-109	Wire mesh synthetic
TPI-204c	Connection set
TPI-423	Pulley Unit + Closing Catch
TPI-702	Counter flange for inlets in 135/145-series

AIR FLOW

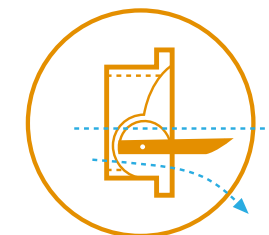
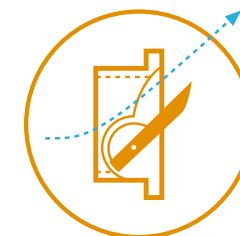
[INFO](#)[DATASHEET](#)[ASSEMBLY](#)[MOUNTING](#)[WORKING](#)[MAINTENANCE](#)



TPI-204C

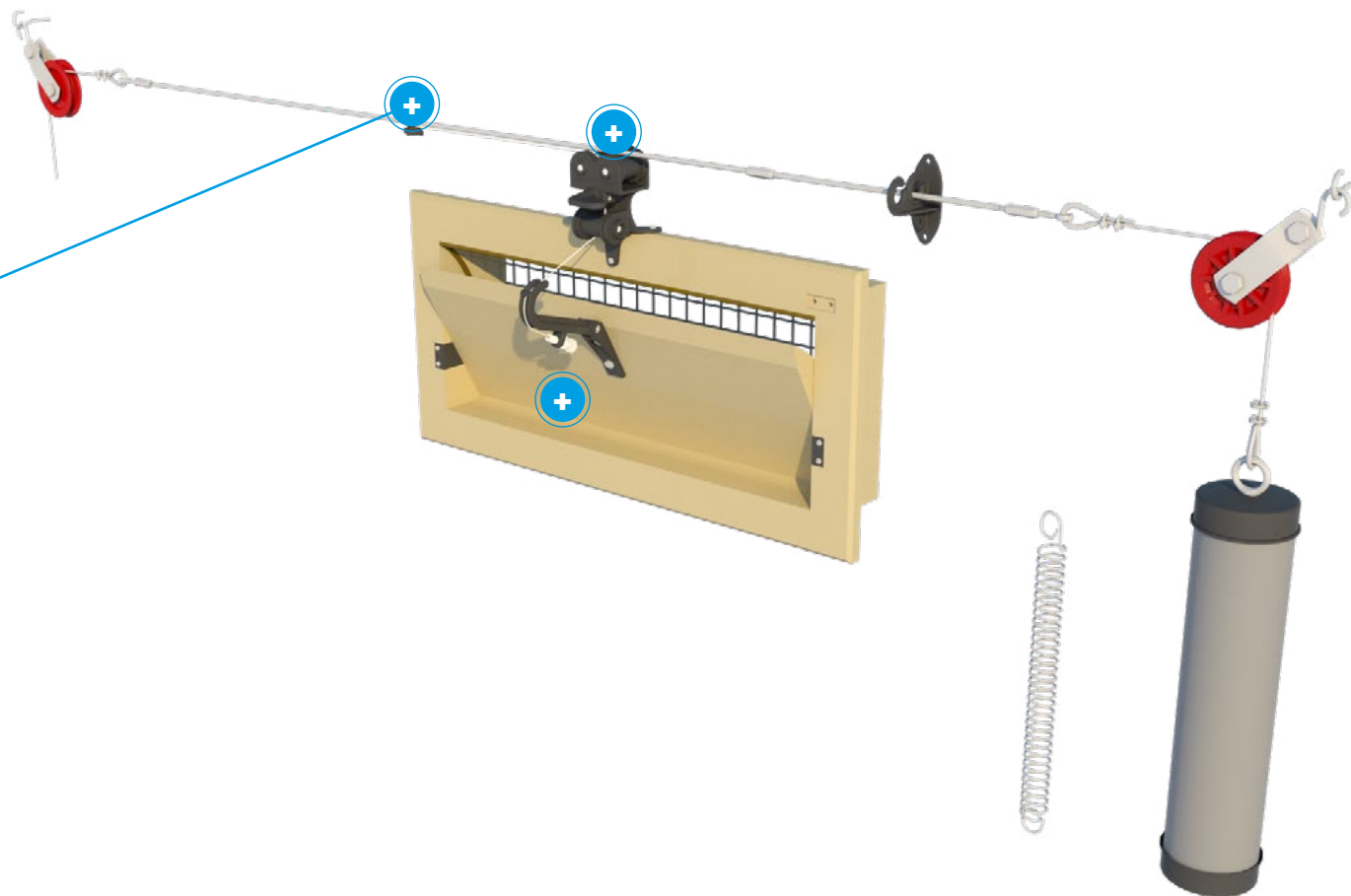

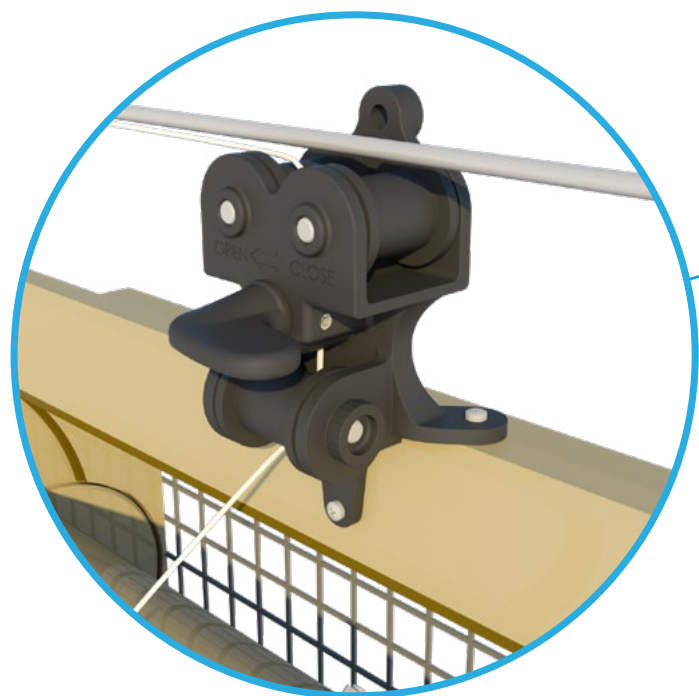

TPI-423

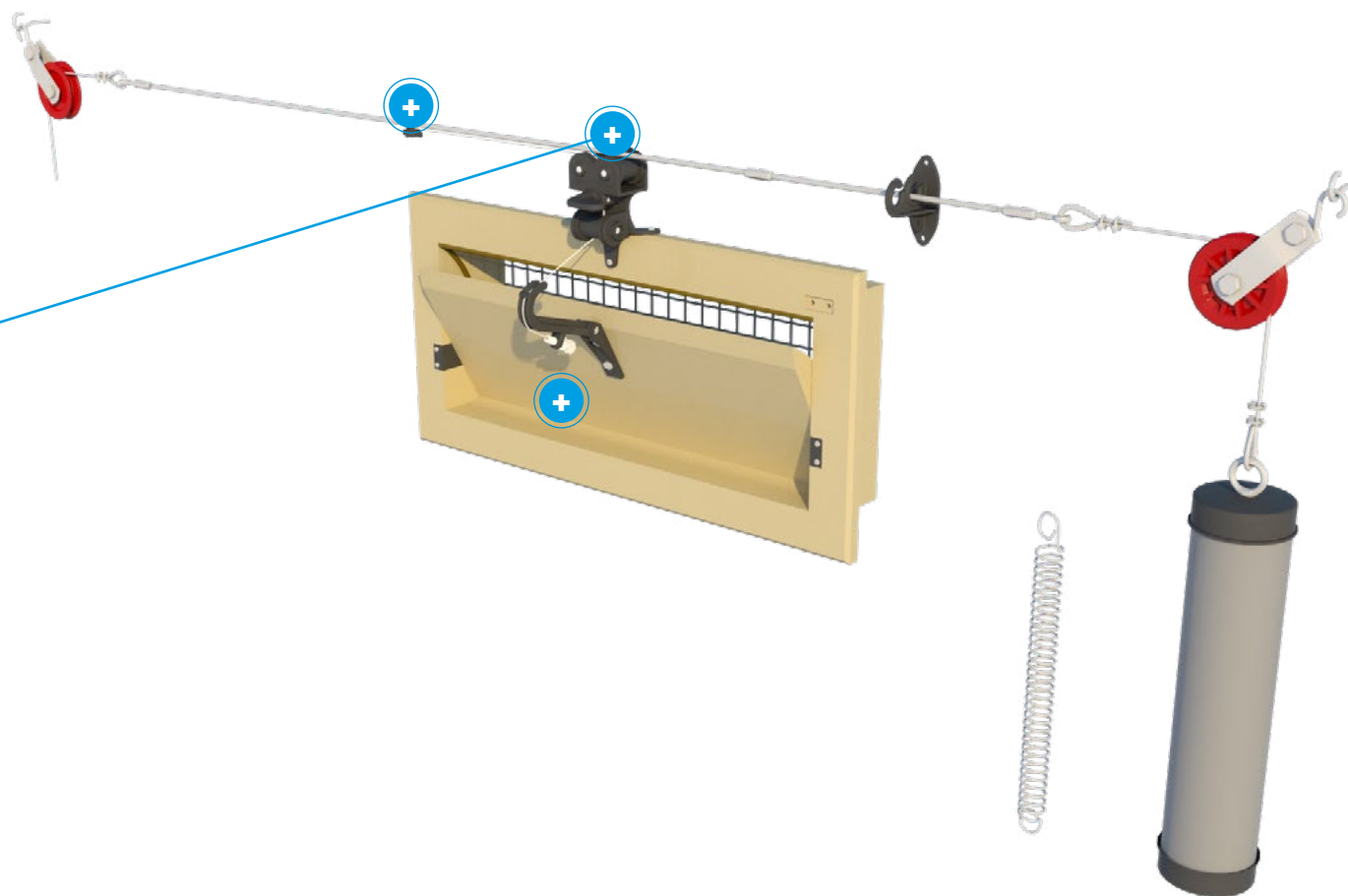

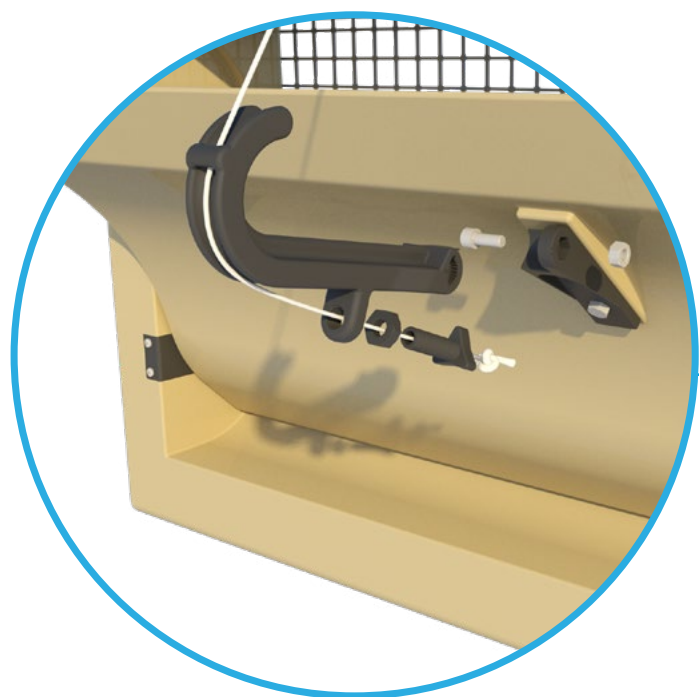

TPI-208 Arm angle position : 2

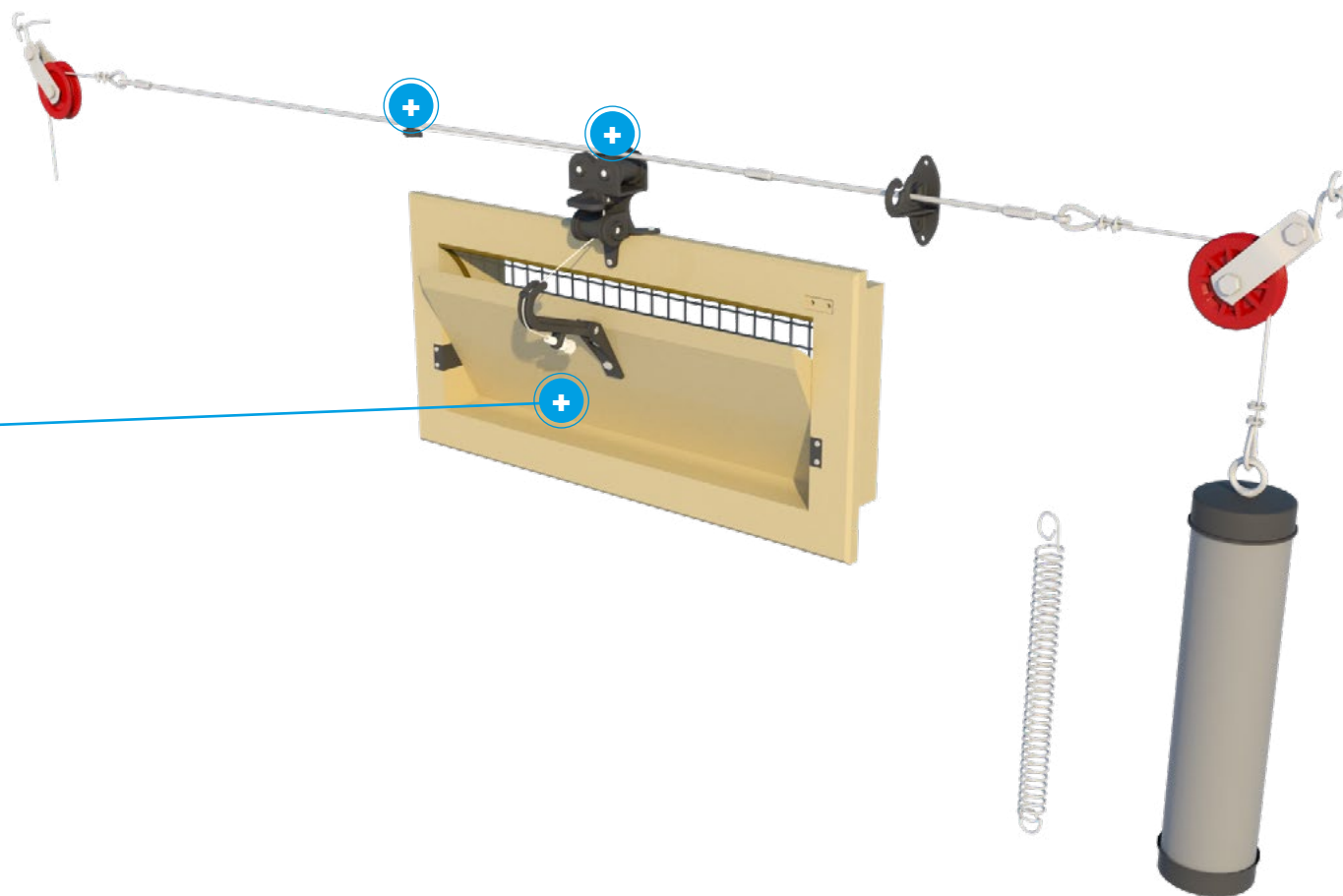

All sizes are in cm and inches

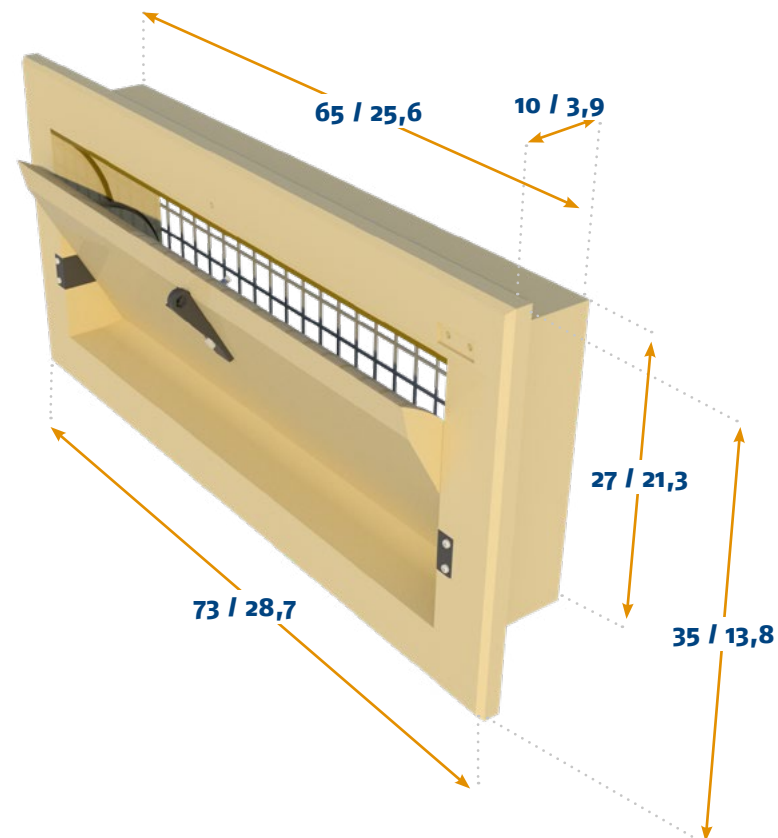
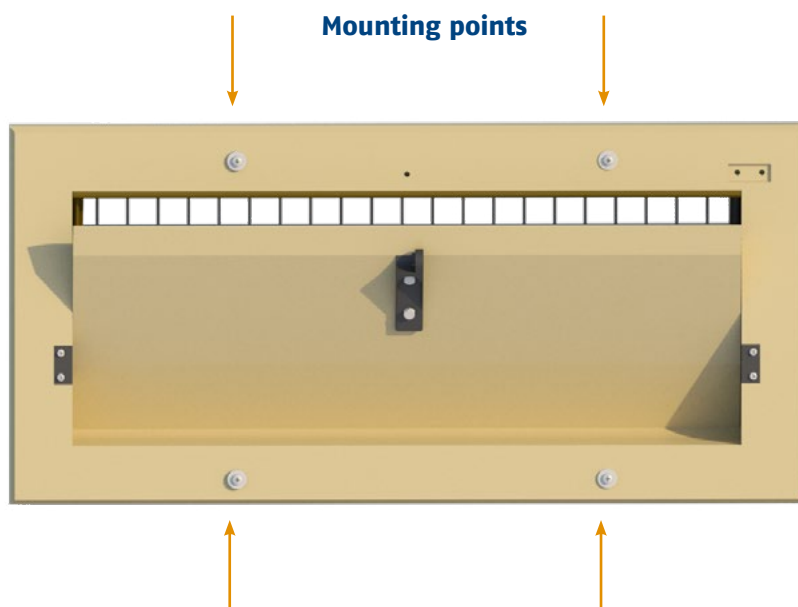

MOUNTING

Mounting type	Wall
Max. hole size in wall	67 cm / 26,4 inch x 29 cm / 11,5 inch

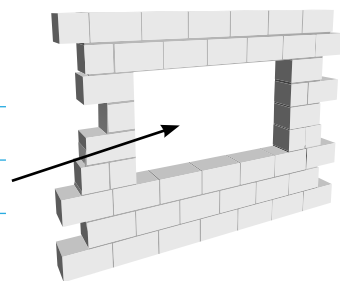

[INFO](#)

[DATASHEET](#)

[ASSEMBLY](#)

[MOUNTING](#)

[WORKING](#)

[MAINTENANCE](#)



AIR FLOW

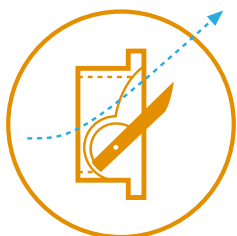

Middle hinged inlet

This middle hinged inlet is made to allow air to also flow underneath the inner flap after opening further then 35%. This helps to guide air downwards to the animals and provide a cooling effect during maximum ventilation.

Straight inner flap

This inlet is equipped with a straight inner flap. Straight flaps guide air in a straight upwards or horizontal direction, never downwards. This is ideal for houses where air should not be directed directly towards or over the animals during maximum ventilation.

Making adjustments

By using the nylon bolt and nut small adjustments can be made to make sure all inlets are closing and opening correctly. The nylon cable clamp and cord can also be used to make small adjustments.

Working with end-weights or springs

We offer two products which can be used to keep tension on the main cable. A PVC cylinder which can be filled with concrete or sand to act as end-weight, or a spring that holds tension on the cable.

Balanced set-up

When placing the motor winch or actuator we normally suggest to divide the inlets in two groups. It is preferable to place the winch or actuator in the middle to equally divide the forces on the main cable.

(see ventilation concepts page for an example)

Use of closing catches

The closing catch on the inlet can be used to permanently close inlets for example during pre-heating. The closing catches can also be used to close certain inlets while continuing to use others. In that case the used inlets can be opened a bit further. In colder climates this can help to offer better resistance to freezing effects.

Self-closing concept

This inlet is also available as a self-closing version. See the ventilation concepts page for more information.

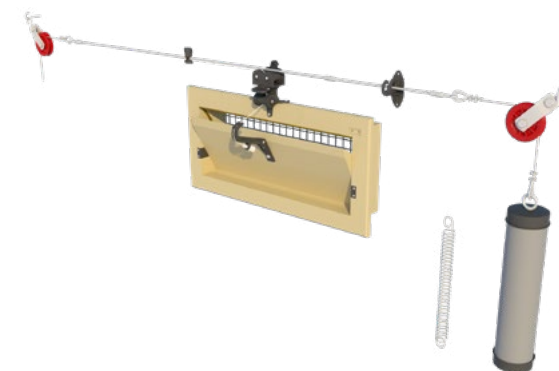

INFO

DATASHEET

ASSEMBLY

MOUNTING

WORKING

MAINTENANCE



145-VFGD

This inlet consists of two single model 145 inlets built on top of each other. With two middle hinged inner valves the air will be divided and also flows underneath the valves when they are opened over 35%. The inlet is controlled by means of two stainless steel side arms connected by a stainless steel rod. This inlet is executed with curved inner valves so when it is opened for maximum ventilation air is also guided downwards to the animals.

(also available in self-closing version. See the ventilation concepts page for more information)



INFO

DATASHEET

ASSEMBLY

MOUNTING

WORKING

MAINTENANCE





145-VFGD DATASHEET



CAPACITY

Model	m ³ /h @ 10 Pa	m ³ /h @ 20 Pa	m ³ /h @ 40 Pa
	cfm @ 0.05 inH ₂ O	cfm @ 0.1 inH ₂ O	cfm @ 0.15 inH ₂ O
145-VFGD	2900	4100	4800
	1908	2693	3296

INFORMATION

Run	11 cm / 4.3 inch
Force	4 kg / 39.2 Newton
Number / pallet (1,20 x 0,80 x 2,40m / 47 x 31,5 x 94,5inch)	28
Weight / per inlet	3,9 kg / 8.6 lbs
Volume / per box	14

OPTIONAL ACCESSORIES

TPI-101 (*2)	Wire mesh galvanized
TPI-109 (*2)	Wire mesh synthetic
TPI-220	Connection set
TPI-307 (*2)	Closing catch + spring
TPI-702	Counter flange for inlets in 135/145-series

AIR FLOW

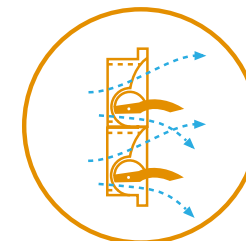
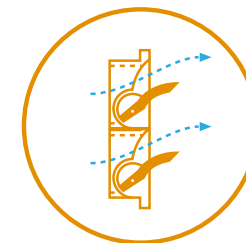

INFO

DATASHEET

ASSEMBLY

MOUNTING

WORKING

MAINTENANCE



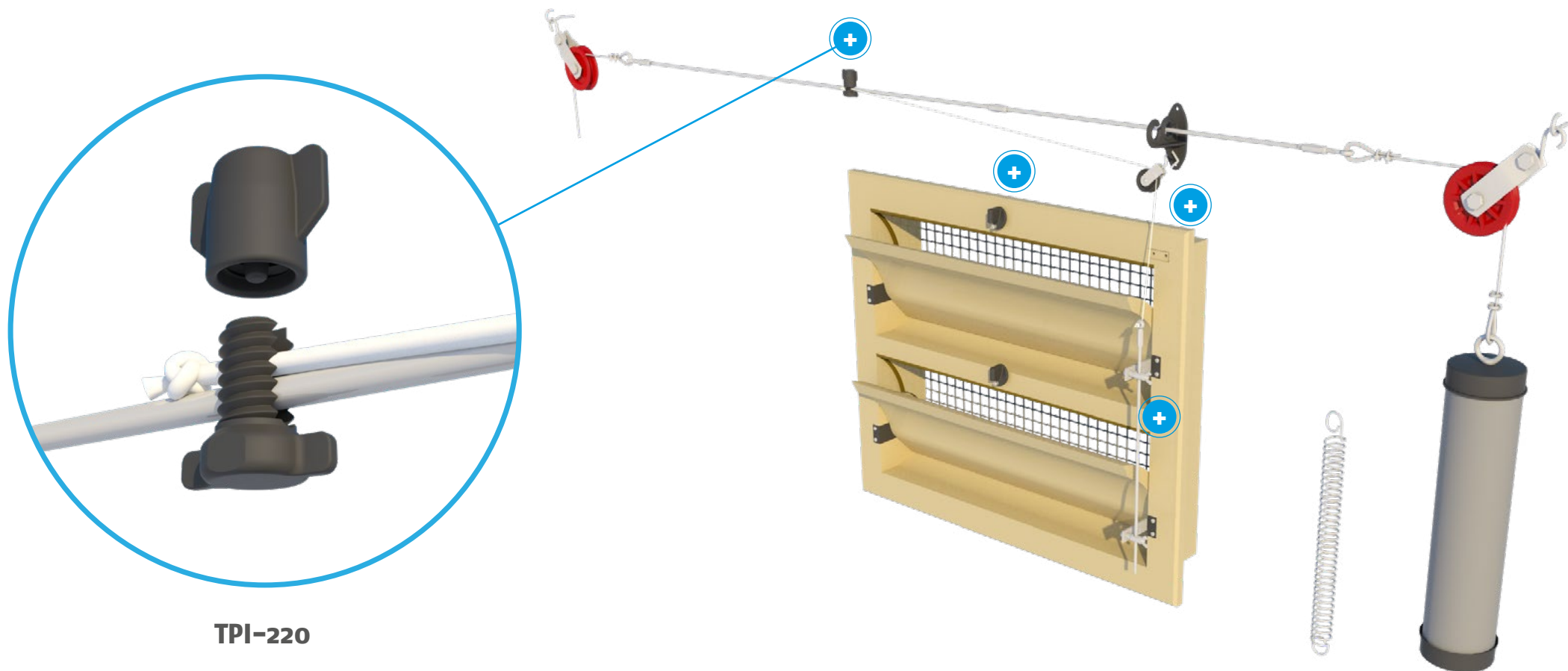

TPI-220

INFO

DATASHEET

ASSEMBLY

MOUNTING

WORKING

MAINTENANCE



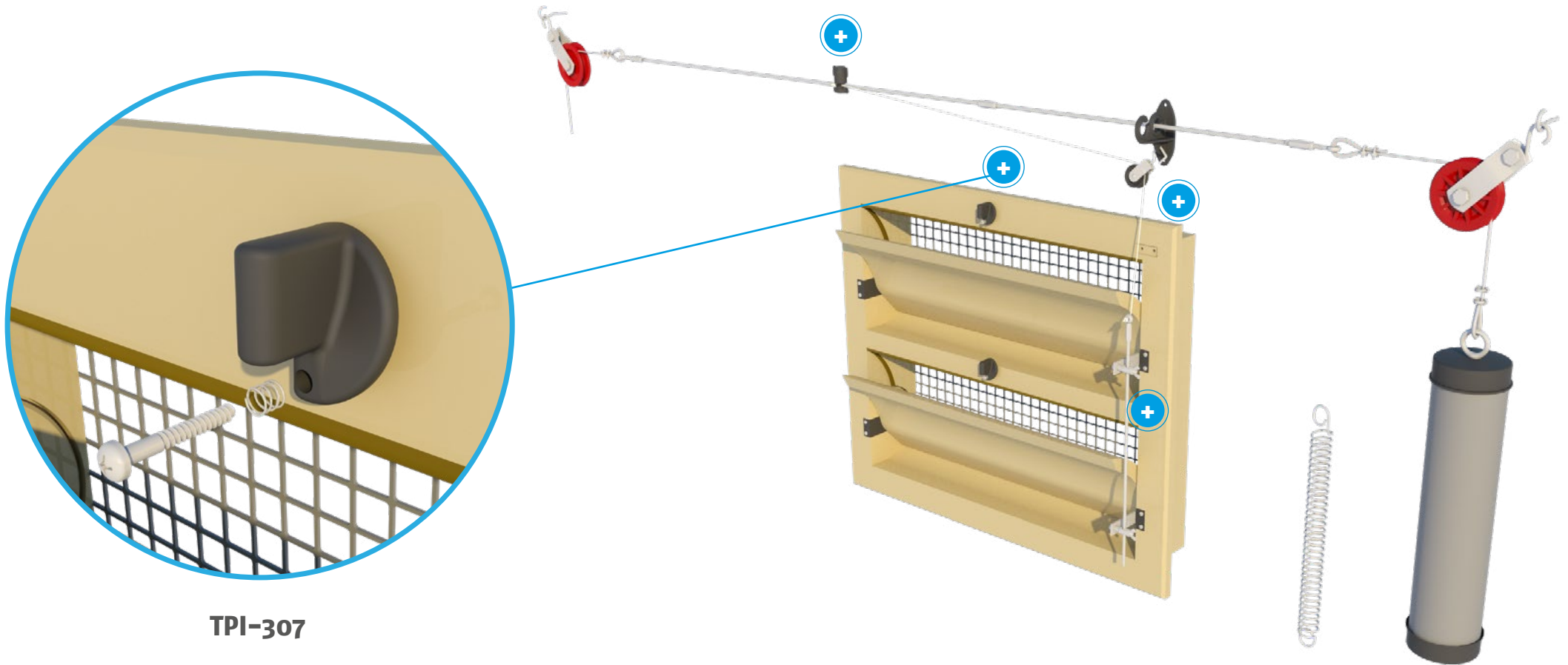

TPI-307

INFO

DATASHEET

ASSEMBLY

MOUNTING

WORKING

MAINTENANCE



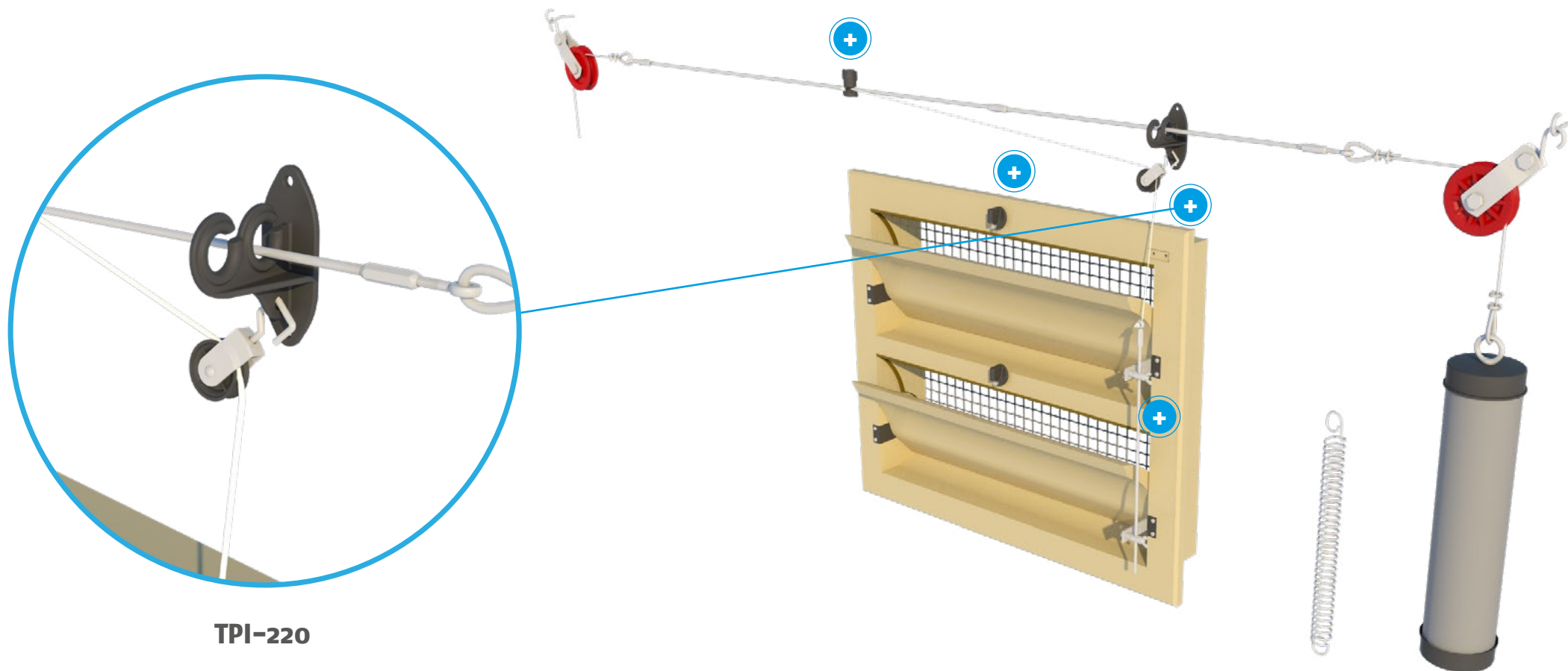

INFO

DATASHEET

ASSEMBLY

MOUNTING

WORKING

MAINTENANCE



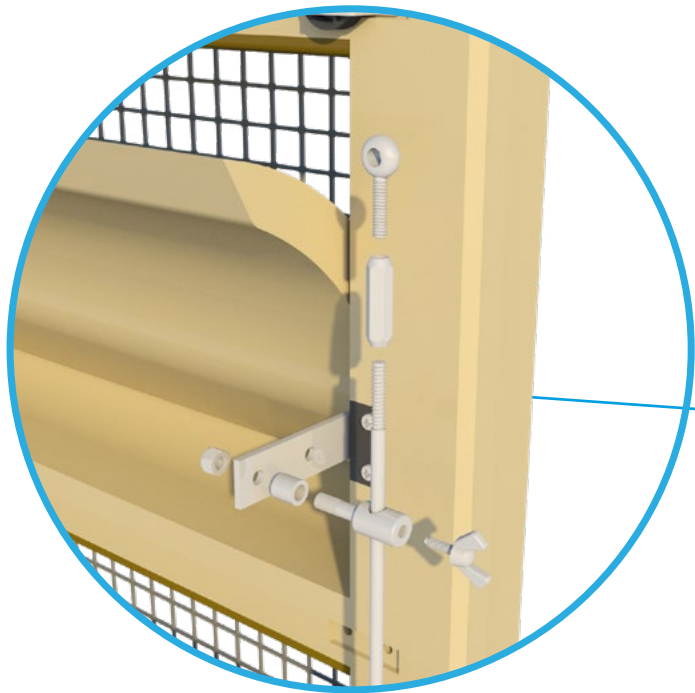

TPI-220

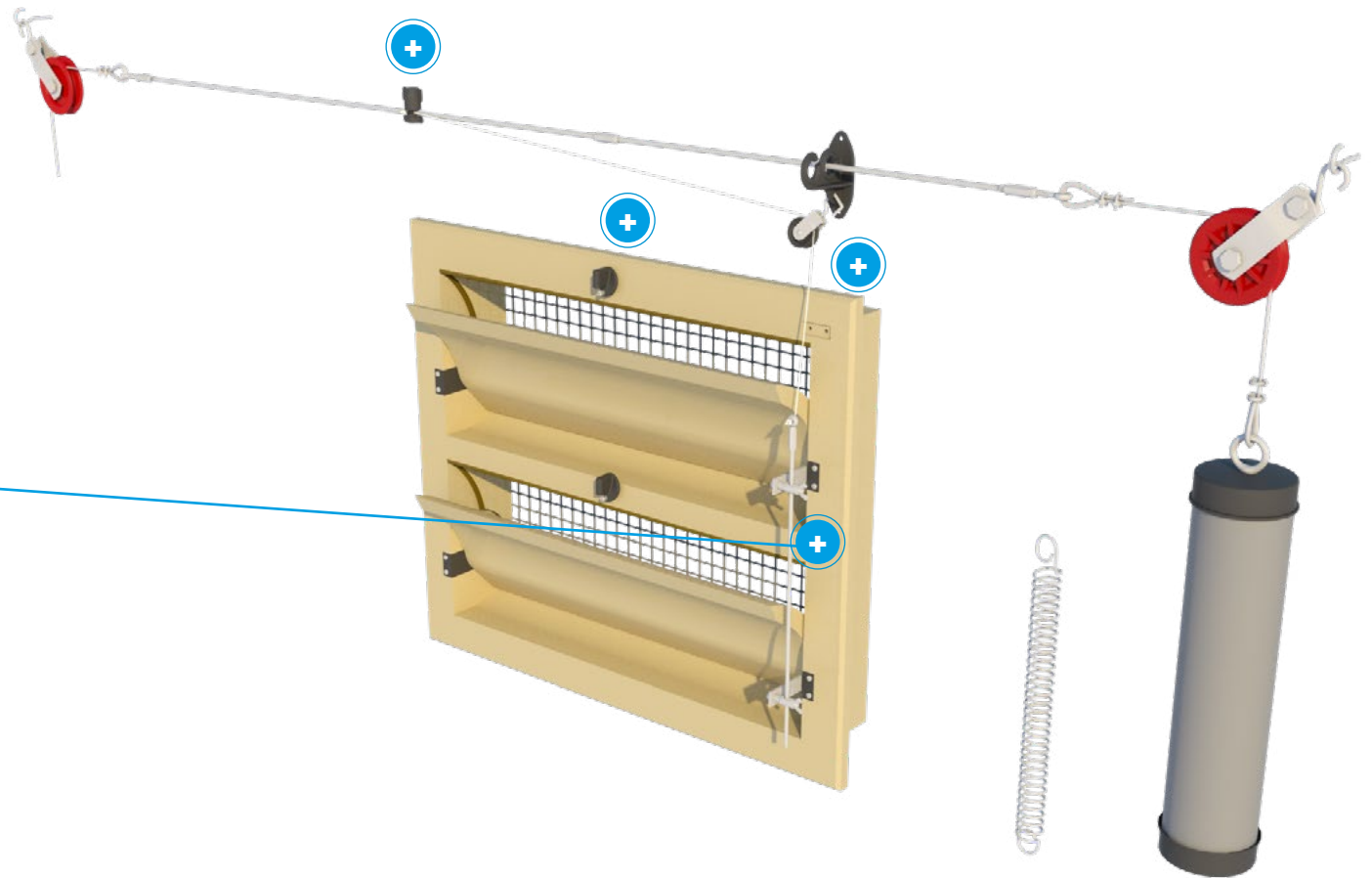

INFO

DATASHEET

ASSEMBLY

MOUNTING

WORKING

MAINTENANCE



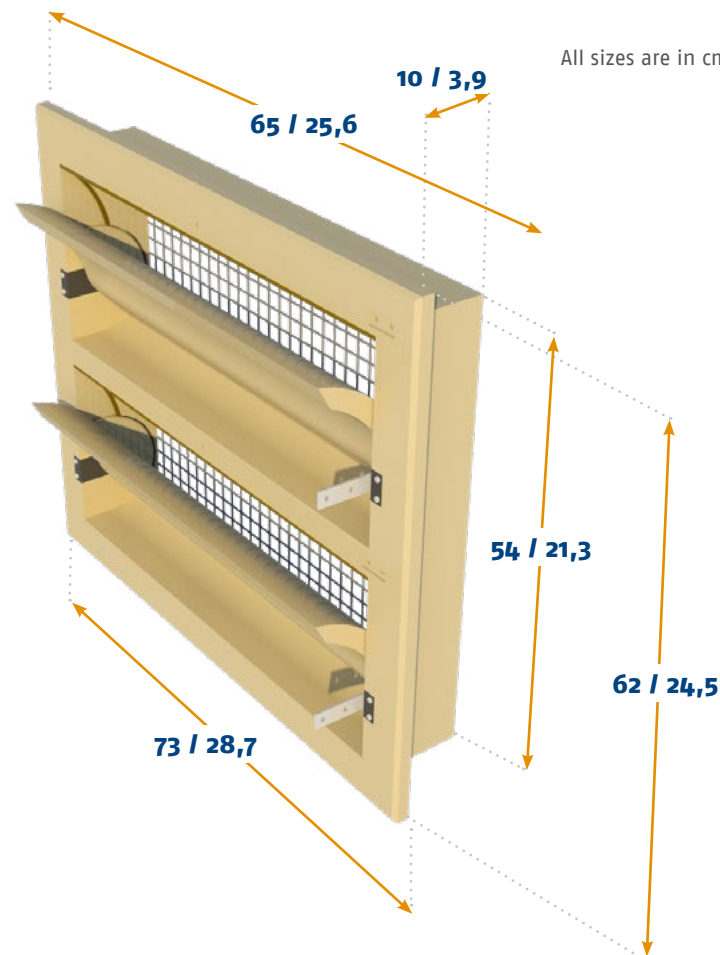
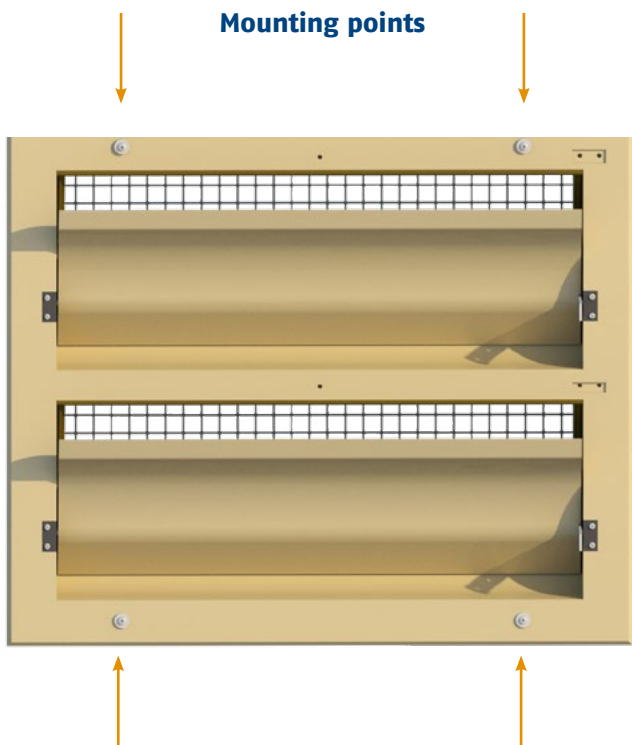

MOUNTING	
Mounting type	Wall
Mounting hole size	67 cm / 26,4 inch x 56 cm / 22,1 inch

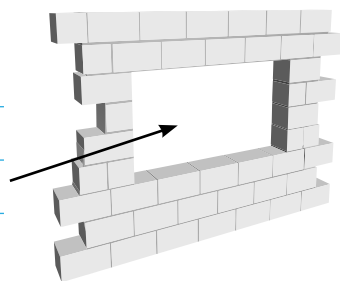

AIR FLOW

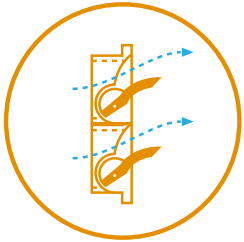

Middle hinged inlet

This middle hinged inlet is made to allow air to also flow underneath the inner flap after opening further then 35%. This helps to guide air downwards to the animals and provide a cooling effect during maximum ventilation.

Curved inner flap

This inlet is equipped with a curved inner flap. Curved flaps guide the air upwards during minimum ventilation, but also downwards after a certain point of opening. This is ideal for houses where air should be directed directly towards or over the animals during maximum ventilation.

Making adjustments

By using the nylon bolt and nut small adjustments can be made to make sure all inlets are closing and opening correctly. The nylon cable clamp and cord can also be used to make small adjustments.

Working with end-weights or springs

We offer two products which can be used to keep tension on the main cable. A PVC cylinder which can be filled with concrete or sand to act as end-weight, or a spring that holds tension on the cable.

Balanced set-up

When placing the motor winch or actuator we normally suggest to divide the inlets in two groups. It is preferable to place the winch or actuator in the middle to equally divide the forces on the main cable.

(see ventilation concepts page for an example)

Use of closing catches

The closing catch on the inlet can be used to permanently close inlets for example during pre-heating. The closing catches can also be used to close certain inlets while continuing to use others. In that case the used inlets can be opened a bit further. In colder climates this can help to offer better resistance to freezing effects.

Self-closing concept

This inlet is also available as an self-closing version. See the ventilation concepts page for more information.

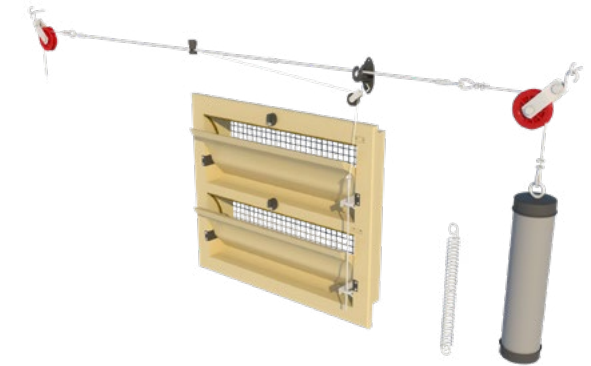

INFO

DATASHEET

ASSEMBLY

MOUNTING

WORKING

MAINTENANCE



145-VFRD

This inlet consists of two single model 145 inlets built on top of each other. With two middle hinged inner valves the air will be divided and also flows underneath the valves when they are opened over 35%. The inlet is controlled by means of two stainless steel side arms connected by a stainless steel rod. This inlet is executed with straight inner valves so even when it is opened for maximum ventilation air is not guided downwards to the animals.

(also available in self-closing version. See the ventilation concepts page for more information)

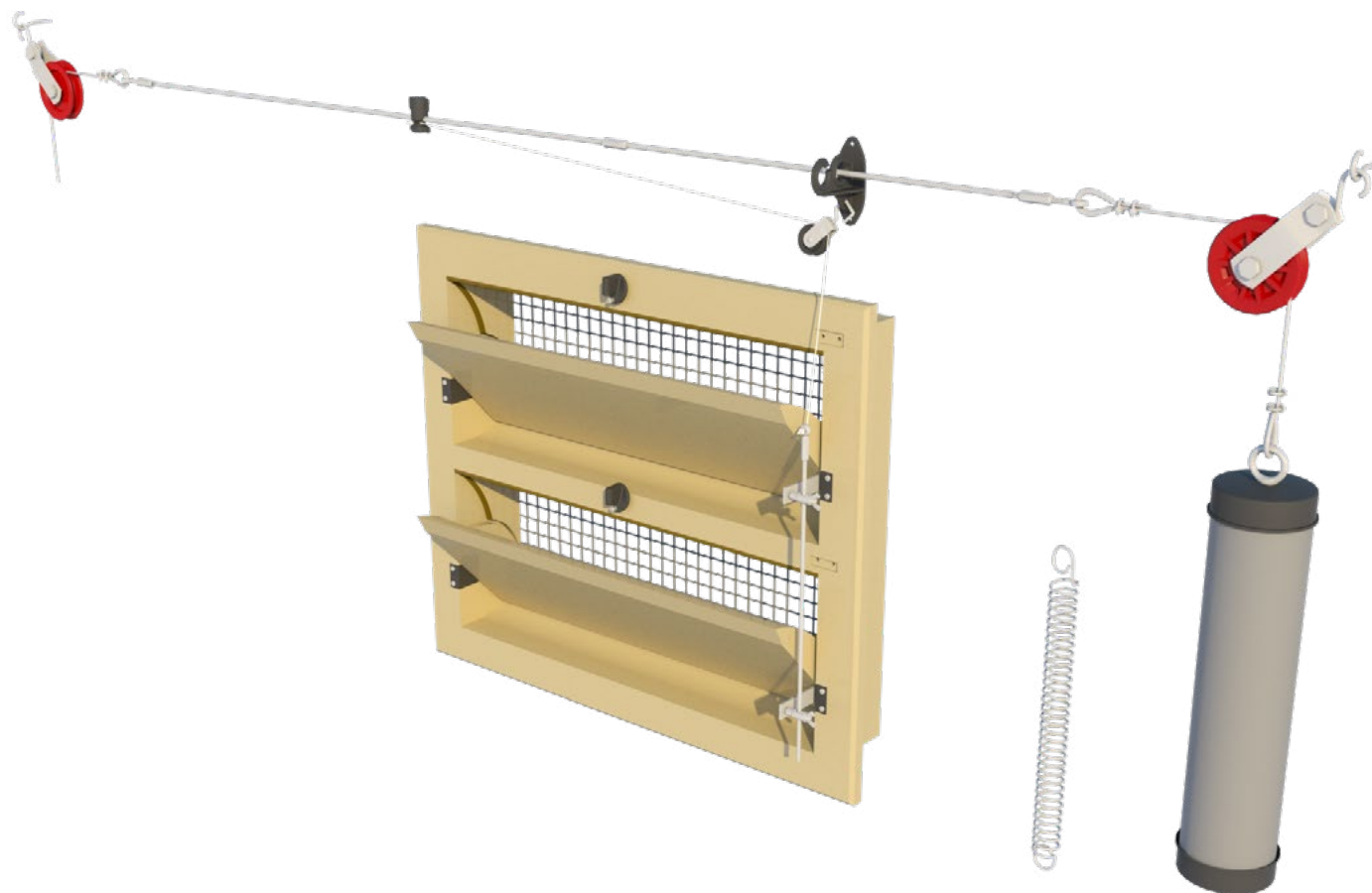

INFO

DATASHEET

ASSEMBLY

MOUNTING

WORKING

MAINTENANCE





145-VFRD DATASHEET



CAPACITY

Model	m ³ /h @ 10 Pa	m ³ /h @ 20 Pa	m ³ /h @ 40 Pa
145-VFRD	2900	4100	4800
	cfm @ 0.05 inH ₂ O	cfm @ 0.1 inH ₂ O	cfm @ 0.15 inH ₂ O
	1908	2693	3296

INFORMATION

Run	11 cm / 4.1 inch
Force	4 kg / 39.2 Newton
Number / pallet (1,20 x 0,80 x 2,40m / 47 x 31,5 x 94,5inch)	28
Weight / per inlet	3,9 kg / 8.6 lbs
Volume / per box	14

OPTIONAL ACCESSORIES

TPI-101 (*2)	Wire mesh galvanized
TPI-109 (*2)	Wire mesh synthetic
TPI-220	Connection set
TPI-307 (*2)	Closing catch + spring
TPI-702	Counter flange for inlets in 135/145-series

AIR FLOW

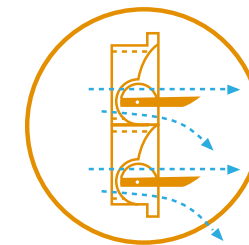
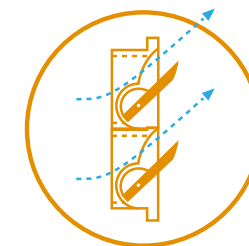

INFO

DATASHEET

ASSEMBLY

MOUNTING

WORKING

MAINTENANCE





TPI-220

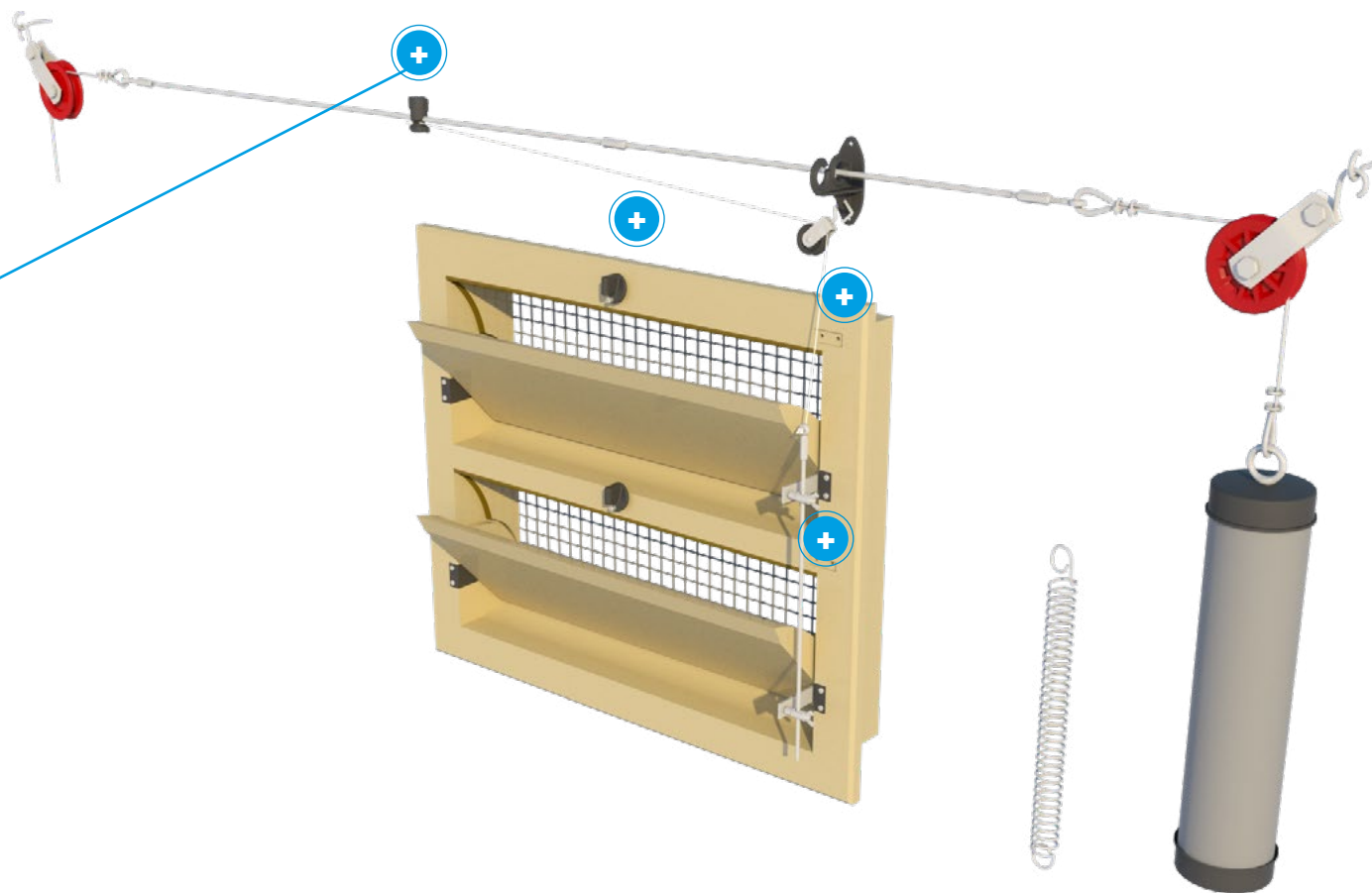

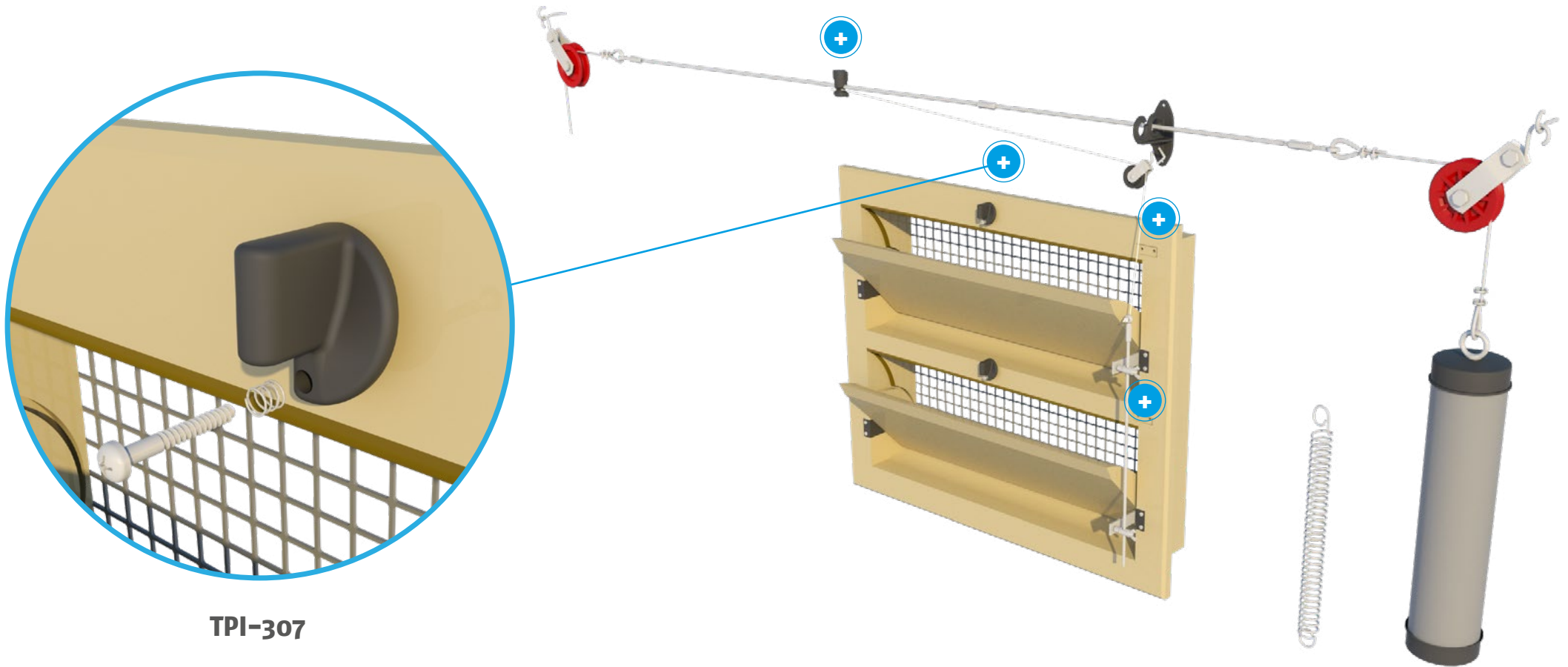

TPI-307

INFO

DATASHEET

ASSEMBLY

MOUNTING

WORKING

MAINTENANCE



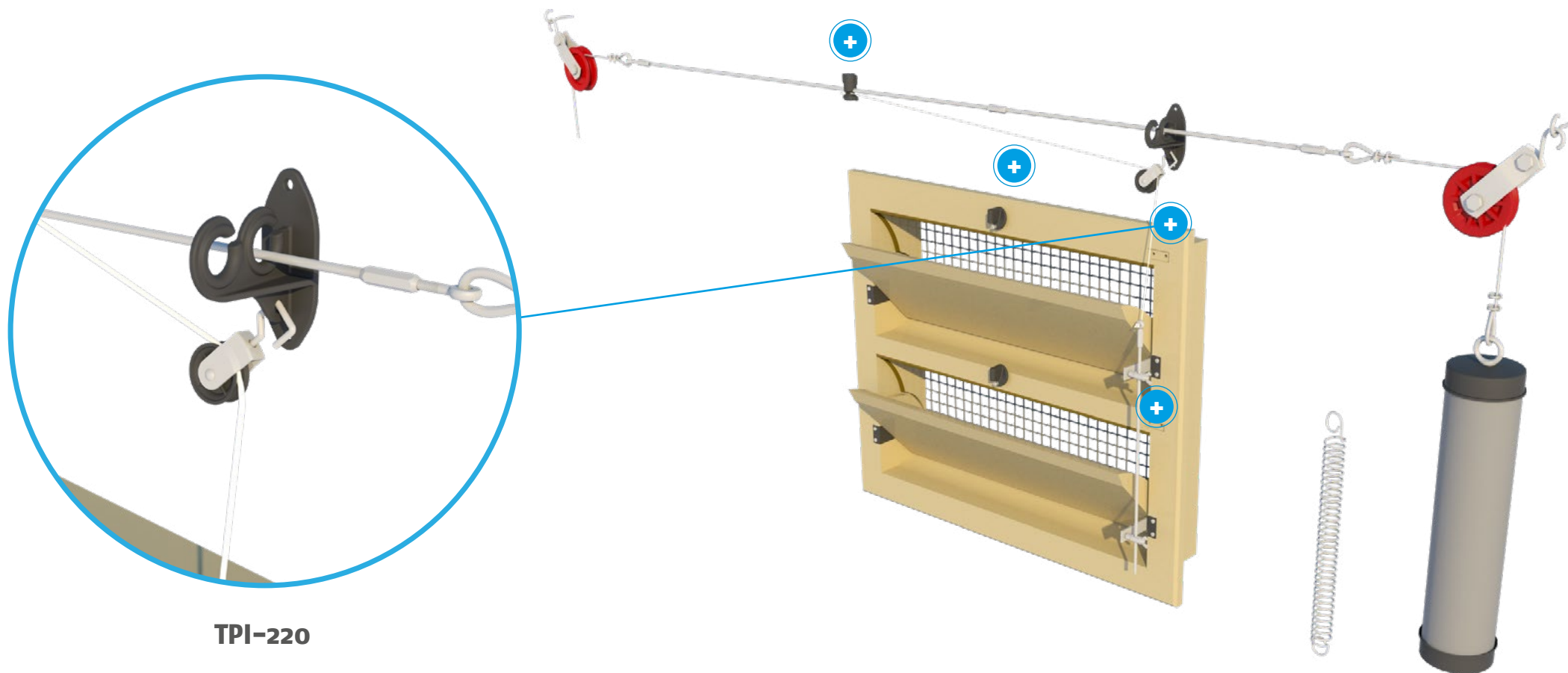

TPI-220

INFO

DATASHEET

ASSEMBLY

MOUNTING

WORKING

MAINTENANCE



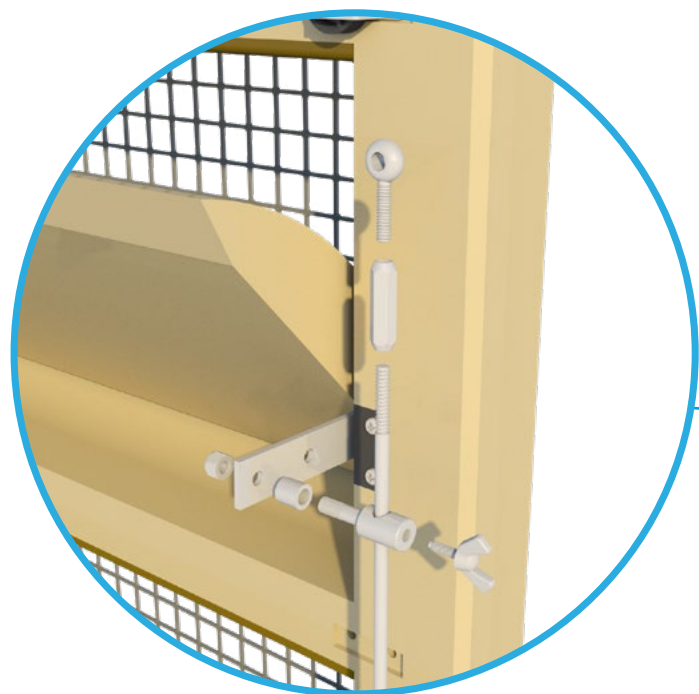

TPI-220

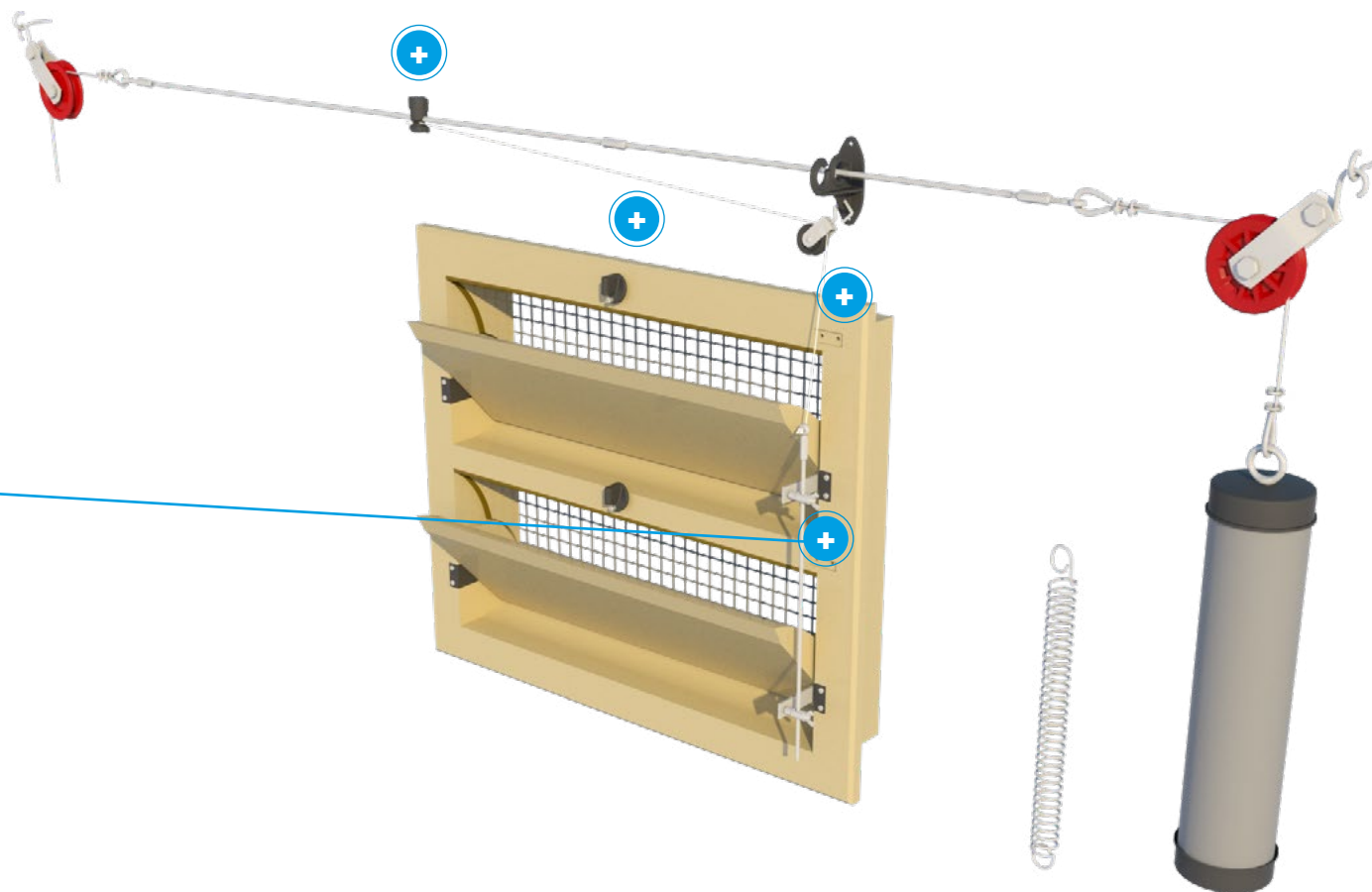

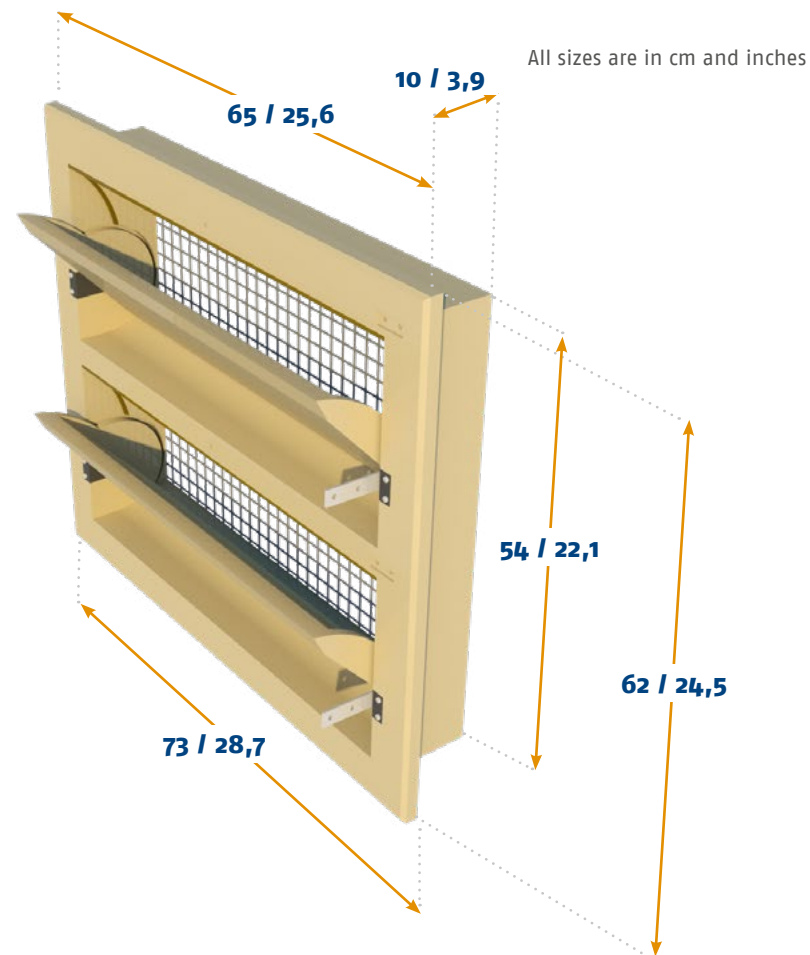
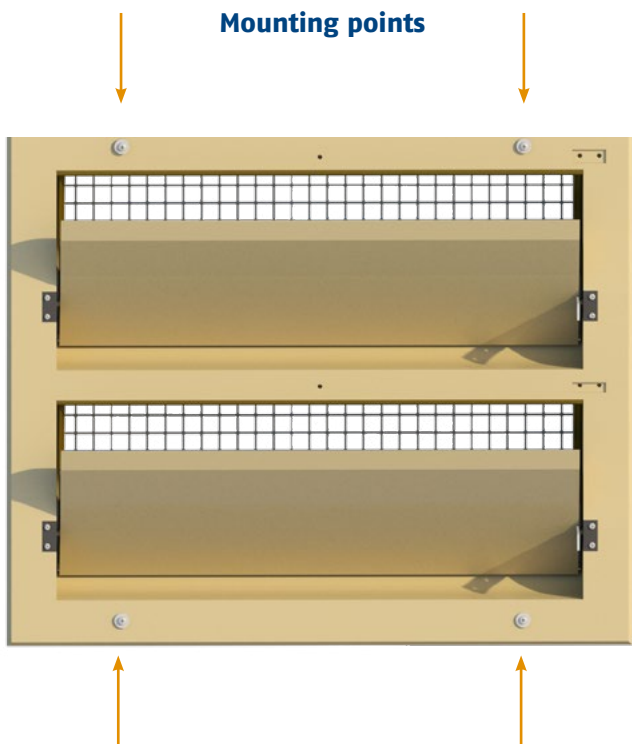

MOUNTING	
Mounting type	Wall
Mounting hole size	67 cm / 26,4 inch x 56 cm / 22,1 inch

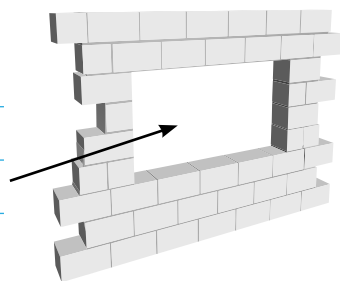

AIR FLOW

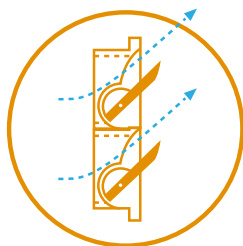

Middle hinged inlet

This middle hinged inlet is made to allow air to also flow underneath the inner flap after opening further then 35%. This helps to guide air downwards to the animals and provide a cooling effect during maximum ventilation.

Straight inner flap

This inlet is equipped with a straight inner flap. Straight flaps guide air in a straight upwards or horizontal direction, never downwards. This is ideal for houses where air should not be directed directly towards or over the animals during maximum ventilation.

Making adjustments

By using the nylon bolt and nut small adjustments can be made to make sure all inlets are closing and opening correctly. The nylon cable clamp and cord can also be used to make small adjustments.

Working with end-weights or springs

We offer two products which can be used to keep tension on the main cable. A PVC cylinder which can be filled with concrete or sand to act as end-weight, or a spring that holds tension on the cable.

Balanced set-up

When placing the motor winch or actuator we normally suggest to divide the inlets in two groups. It is preferable to place the winch or actuator in the middle to equally divide the forces on the main cable.

(see ventilation concepts page for an example)

Use of closing catches

The closing catch on the inlet can be used to permanently close inlets for example during pre-heating. The closing catches can also be used to close certain inlets while continuing to use others. In that case the used inlets can be opened a bit further. In colder climates this can help to offer better resistance to freezing effects.

Self-closing concept

This inlet is also available as an self-closing version. See the ventilation concepts page for more information.



INFO

DATASHEET

ASSEMBLY

MOUNTING

WORKING

MAINTENANCE



145-VFGT

This inlet consists of three single model 145 inlets built on top of each other. With three middle hinged inner valves the air will be divided and also flows underneath the valves when they are opened over 35%. The inlet is controlled by means of three stainless steel side arms connected by a stainless steel rod. This inlet is executed with curved inner valves so when it is opened for maximum ventilation air is also guided downwards to the animals.

(also available in self-closing version. See the ventilation concepts page for more information)



INFO

DATASHEET

ASSEMBLY

MOUNTING

WORKING

MAINTENANCE



CAPACITY

Model	m ³ /h @ 10 Pa	m ³ /h @ 20 Pa	m ³ /h @ 40 Pa
145-VFGT	4350	6150	8700
	cfm @ 0.05 inH ₂ O	cfm @ 0.1 inH ₂ O	cfm @ 0.15 inH ₂ O
	2863	4039	4945

INFORMATION

Run	11 cm / 4.3 inch
Force	6 kg / 58.8 Newton
Number / pallet (1,20 x 0,80 x 2,40m / 47 x 31,5 x 94,5inch)	16
Weight / per inlet	5,8 kg / 12.8 lbs
Volume / per box	8

OPTIONAL ACCESSORIES

TPI-101 (*3)	Wire mesh galvanized
TPI-109 (*3)	Wire mesh synthetic
TPI-219	Connection set
TPI-307 (*3)	Closing catch + spring
TPI-702	Counter flange for inlets in 135/145-series

AIR FLOW

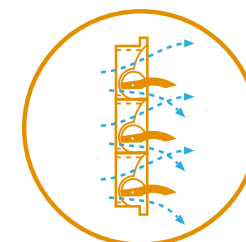
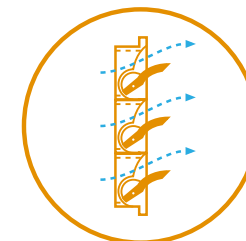
[INFO](#)
[DATASHEET](#)
[ASSEMBLY](#)
[MOUNTING](#)
[WORKING](#)
[MAINTENANCE](#)



TPI-219

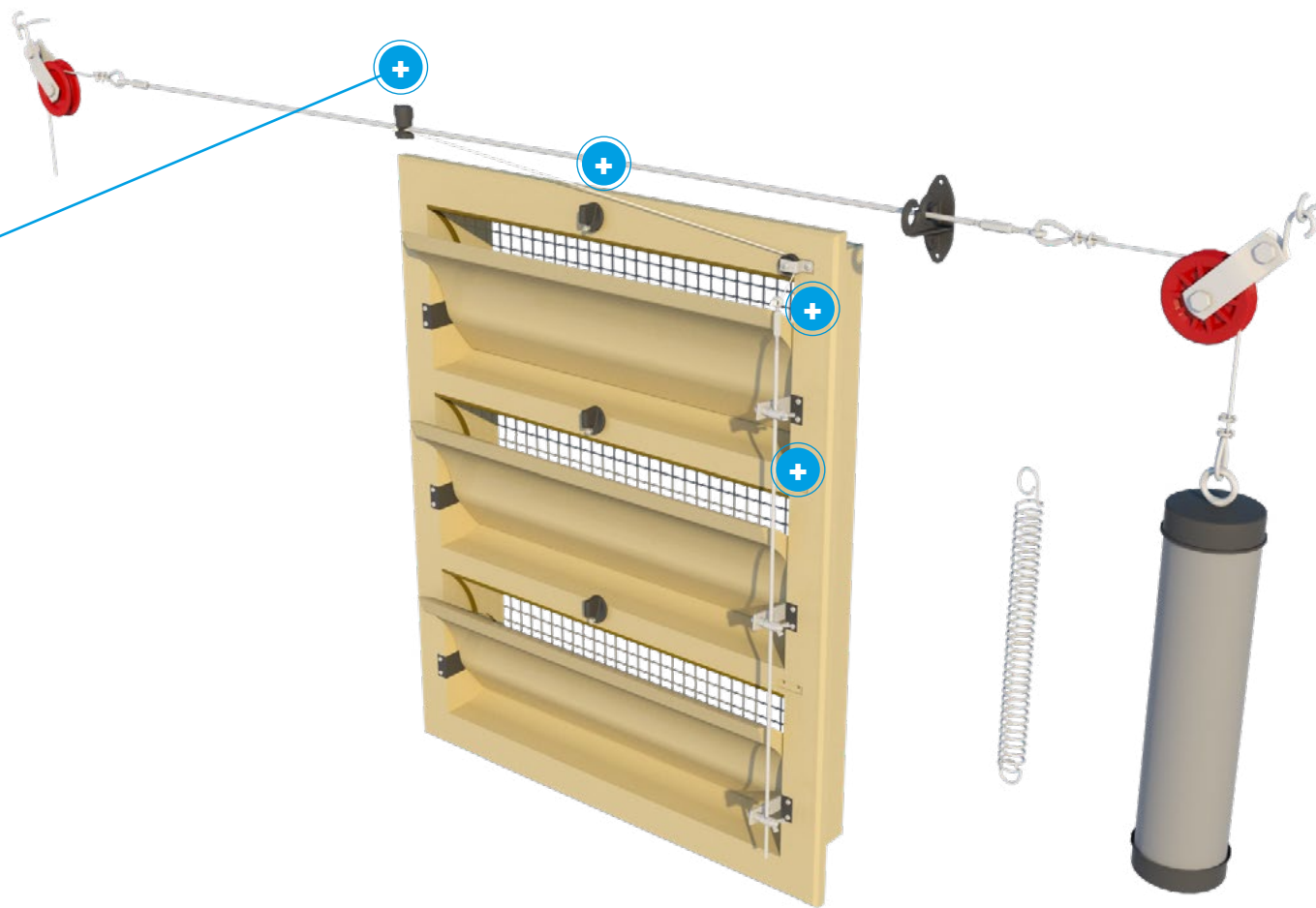

[INFO](#)

[DATASHEET](#)

[ASSEMBLY](#)

[MOUNTING](#)

[WORKING](#)

[MAINTENANCE](#)





TPI-307

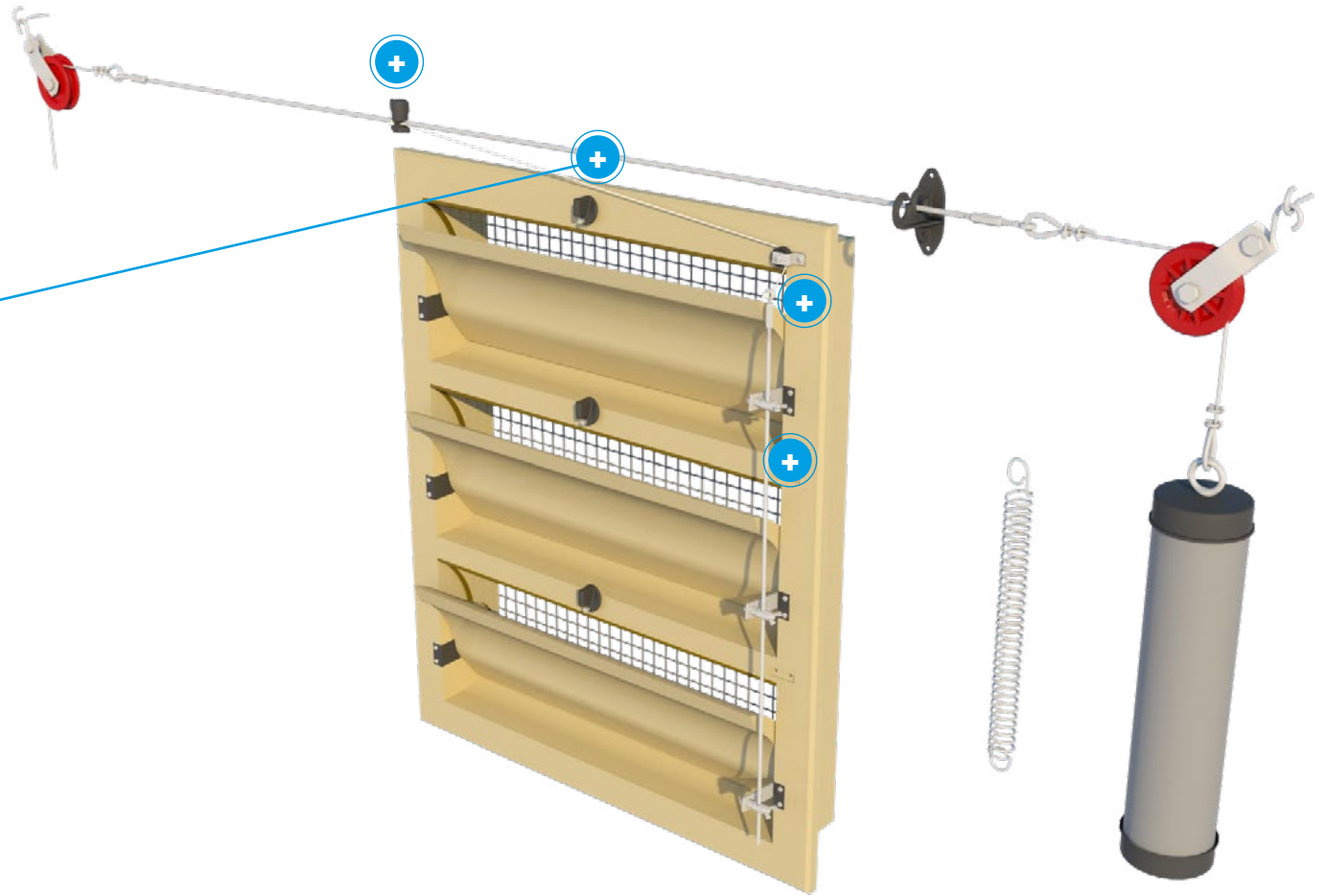

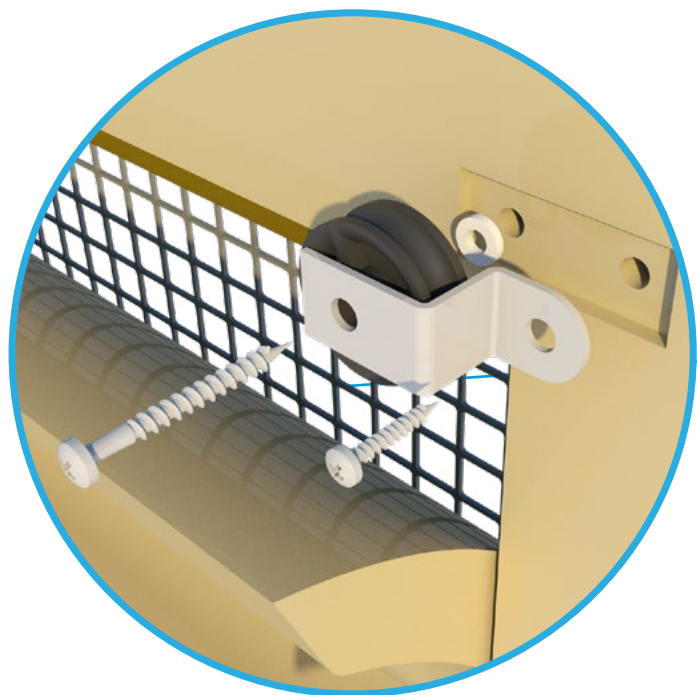

TPI-219

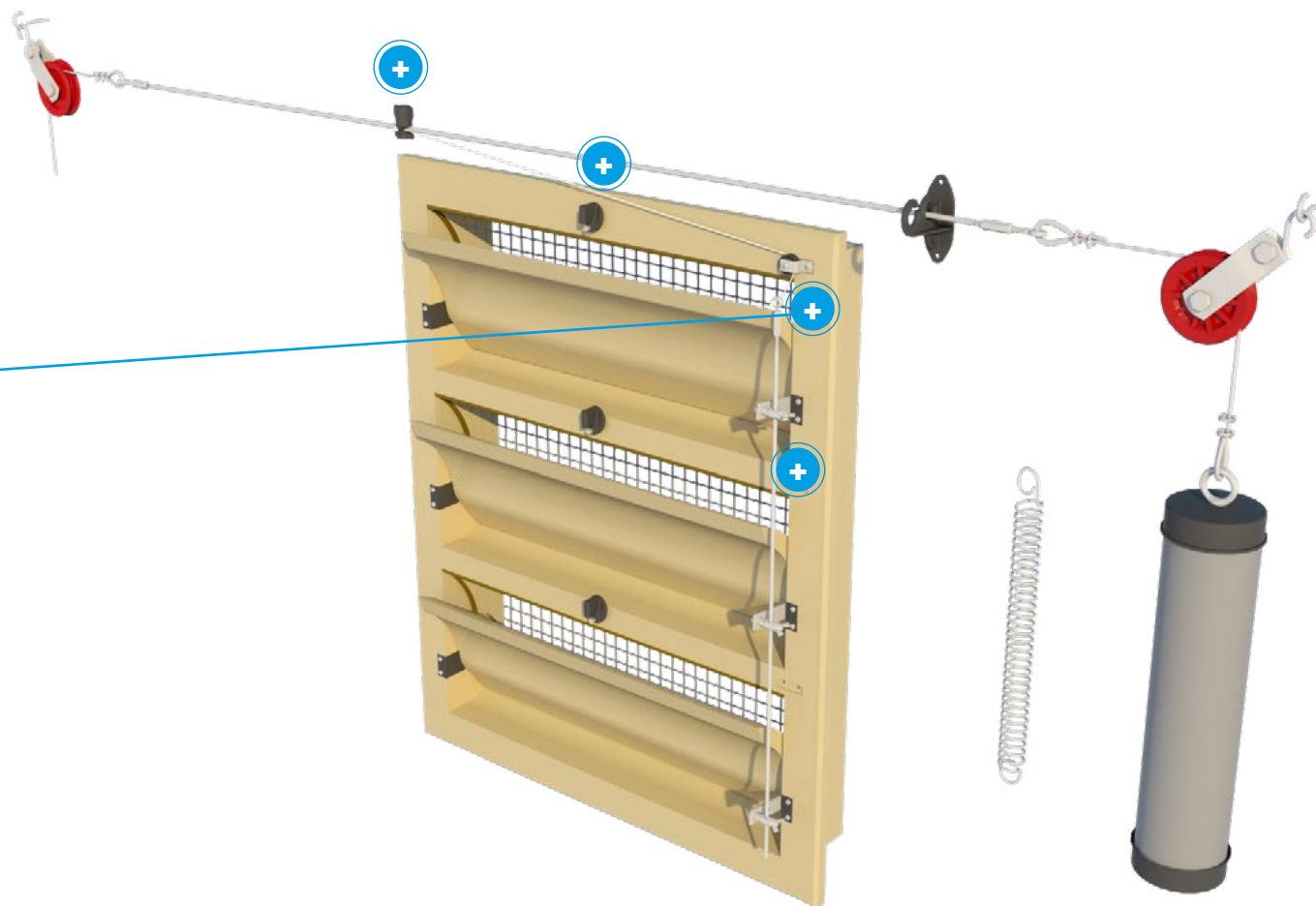

INFO

DATASHEET

ASSEMBLY

MOUNTING

WORKING

MAINTENANCE



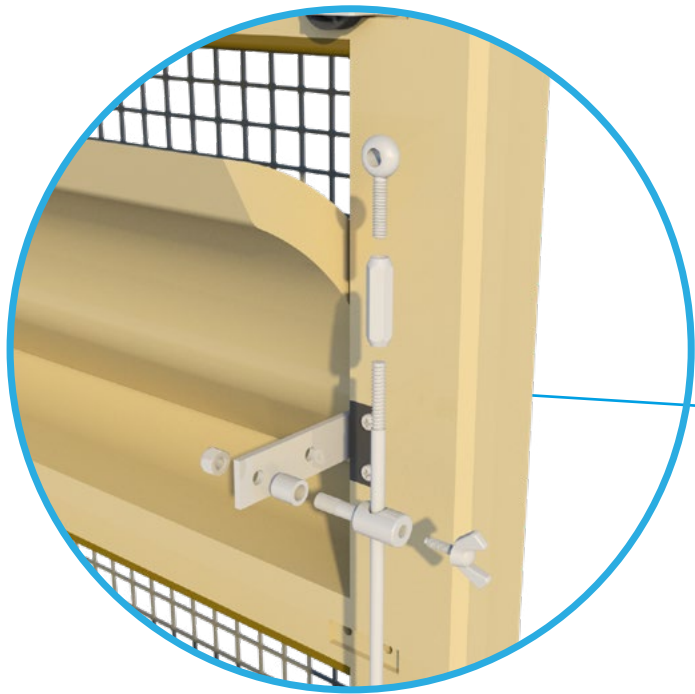

TPI-219

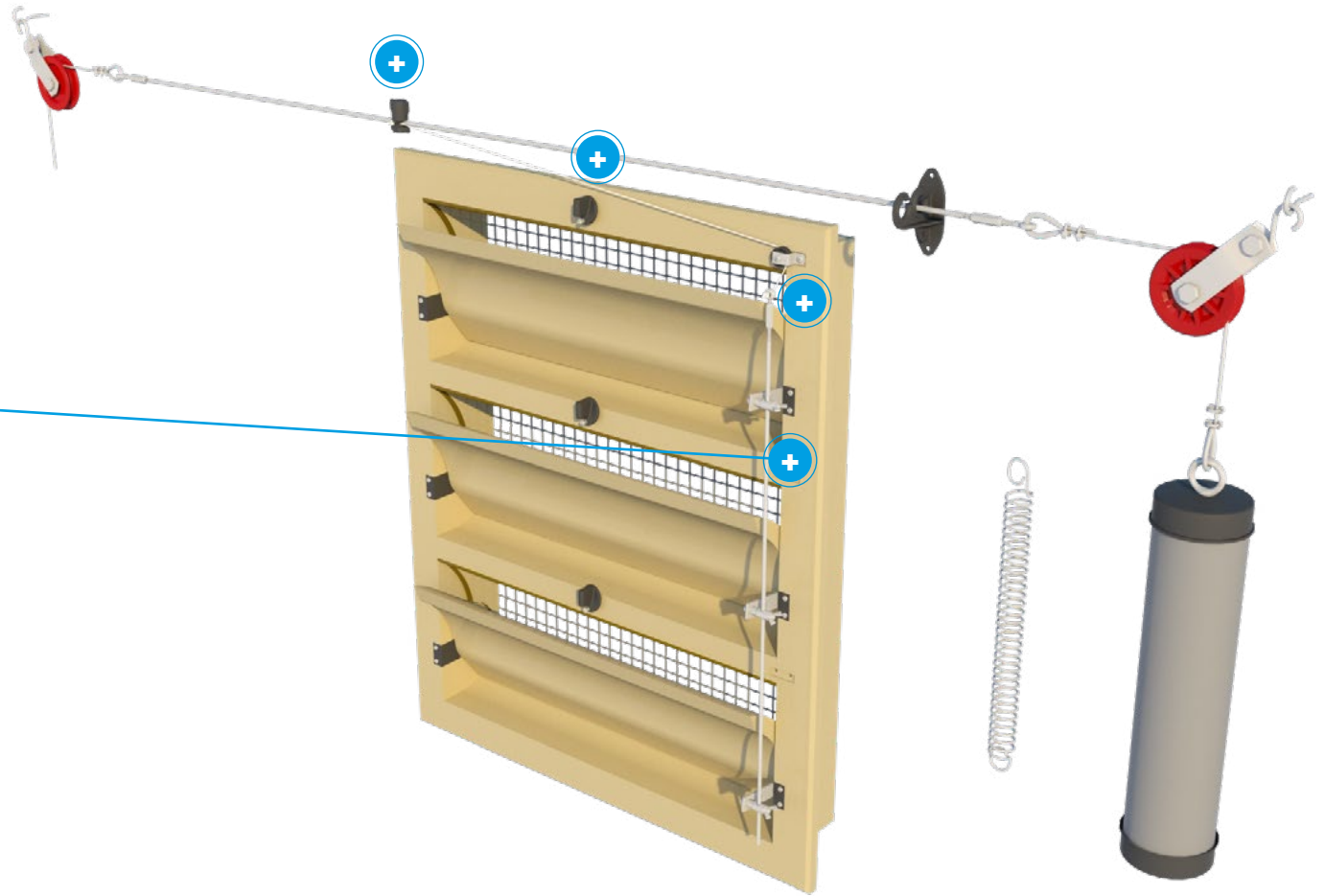

INFO

DATASHEET

ASSEMBLY

MOUNTING

WORKING

MAINTENANCE



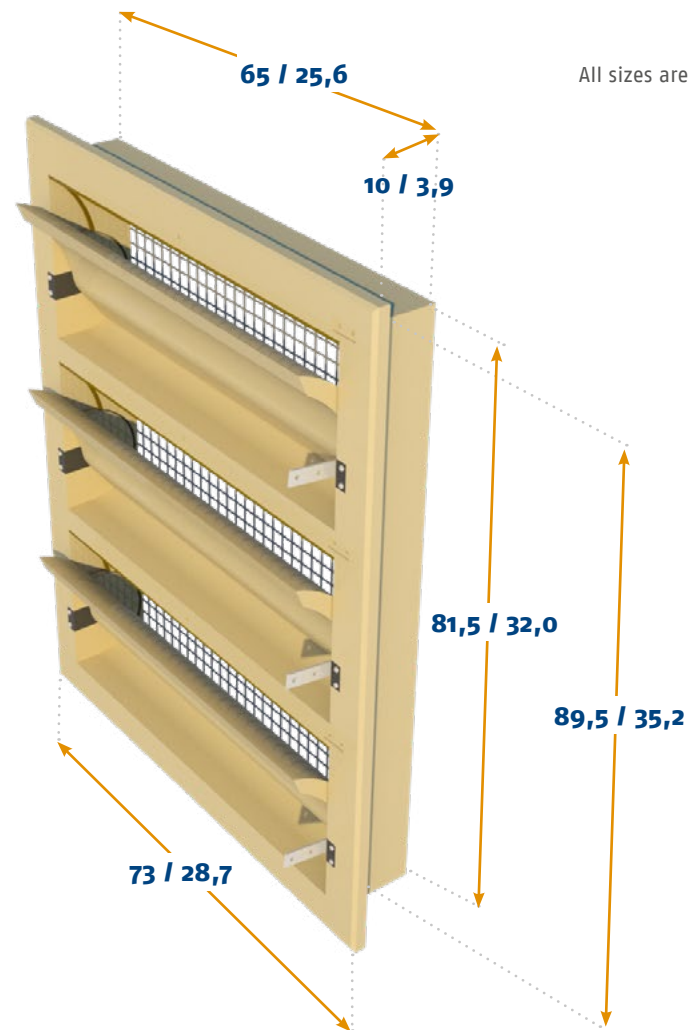
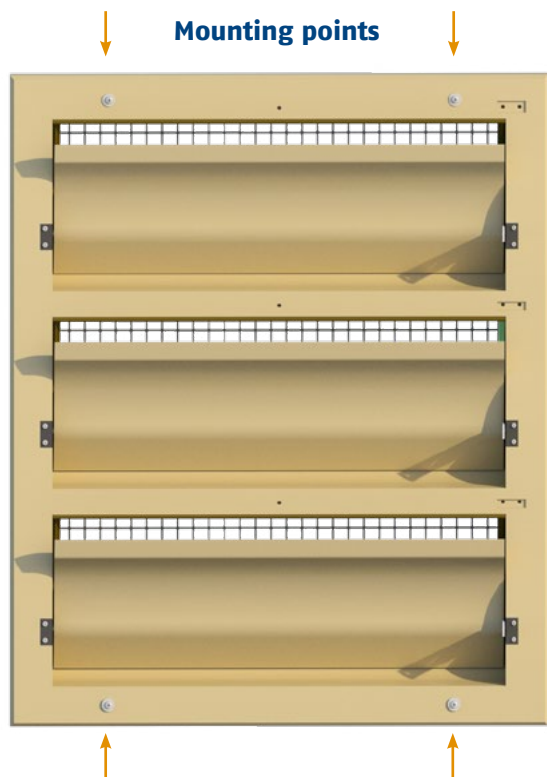

All sizes are in cm and inches

MOUNTING

Mounting type	Wall
Mounting hole size	67 cm x 2,4 inch / 83,5 cm / 32,8 inch

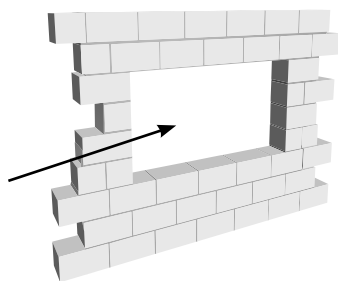

INFO

DATASHEET

ASSEMBLY

MOUNTING

WORKING

MAINTENANCE



AIR FLOW

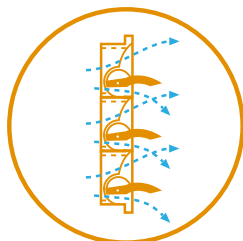
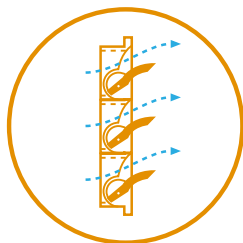

Middle hinged inlet

This middle hinged inlet is made to allow air to also flow underneath the inner flap after opening further than 35%. This helps to guide air downwards to the animals and provide a cooling effect during maximum ventilation.

Curved inner flap

This inlet is equipped with a curved inner flap. Curved flaps guide the air upwards during minimum ventilation, but also downwards after a certain point of opening. This is ideal for houses where air should be directed directly towards or over the animals during maximum ventilation.

Making adjustments

By using the nylon bolt and nut small adjustments can be made to make sure all inlets are closing and opening correctly. The nylon cable clamp and cord can also be used to make small adjustments.

Working with end-weights or springs

We offer two products which can be used to keep tension on the main cable. A PVC cylinder which can be filled with concrete or sand to act as end-weight, or a spring that holds tension on the cable.

Balanced set-up

When placing the motor winch or actuator we normally suggest to divide the inlets in two groups. It is preferable to place the winch or actuator in the middle to equally divide the forces on the main cable.

(see ventilation concepts page for an example)

Use of closing catches

The closing catch on the inlet can be used to permanently close inlets for example during pre-heating. The closing catches can also be used to close certain inlets while continuing to use others. In that case the used inlets can be opened a bit further. In colder climates this can help to offer better resistance to freezing effects.

Self-closing concept

This inlet is also available as a self-closing version. See the ventilation concepts page for more information.



INFO

DATASHEET

ASSEMBLY

MOUNTING

WORKING

MAINTENANCE



145-VFRT

This inlet consists of three single model 145 inlets built on top of each other. With three middle hinged inner valves the air will be divided and also flows underneath the valves when they are opened over 35%. The inlet is controlled by means of three stainless steel side arms connected by a stainless steel rod. This inlet is executed with straight inner flaps so even when it is opened for maximum ventilation air is not guided downwards to the animals.

(also available in self-closing version. See the ventilation concepts page for more information)



INFO

DATASHEET

ASSEMBLY

MOUNTING

WORKING

MAINTENANCE





145-VFRT DATASHEET



CAPACITY

Model	m ³ /h @ 10 Pa	m ³ /h @ 20 Pa	m ³ /h @ 40 Pa
145-VFRT	4350	6150	8700
	cfm @ 0.05 inH ₂ O	cfm @ 0.1 inH ₂ O	cfm @ 0.15 inH ₂ O
	2863	4039	4945

INFORMATION

Run	11 cm / 4.3 inch
Force	6 kg / 58.8 Newton
Number / pallet (1,20 x 0,80 x 2,40m / 47 x 31,5 x 94,5inch)	16
Weight / per inlet	5,8 kg / 12.8 lbs
Volume / per box	8

OPTIONAL ACCESSORIES

TPI-101 (*3)	Wire mesh galvanized
TPI-109 (*3)	Wire mesh synthetic
TPI-219	Connection set
TPI-307 (*3)	Closing catch + spring
TPI-702	Counter flange for inlets in 135/145-series

AIR FLOW

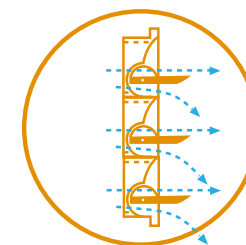
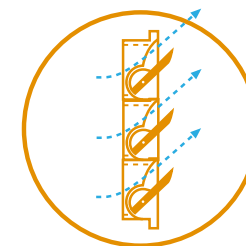

INFO

DATASHEET

ASSEMBLY

MOUNTING

WORKING

MAINTENANCE





TPI-219

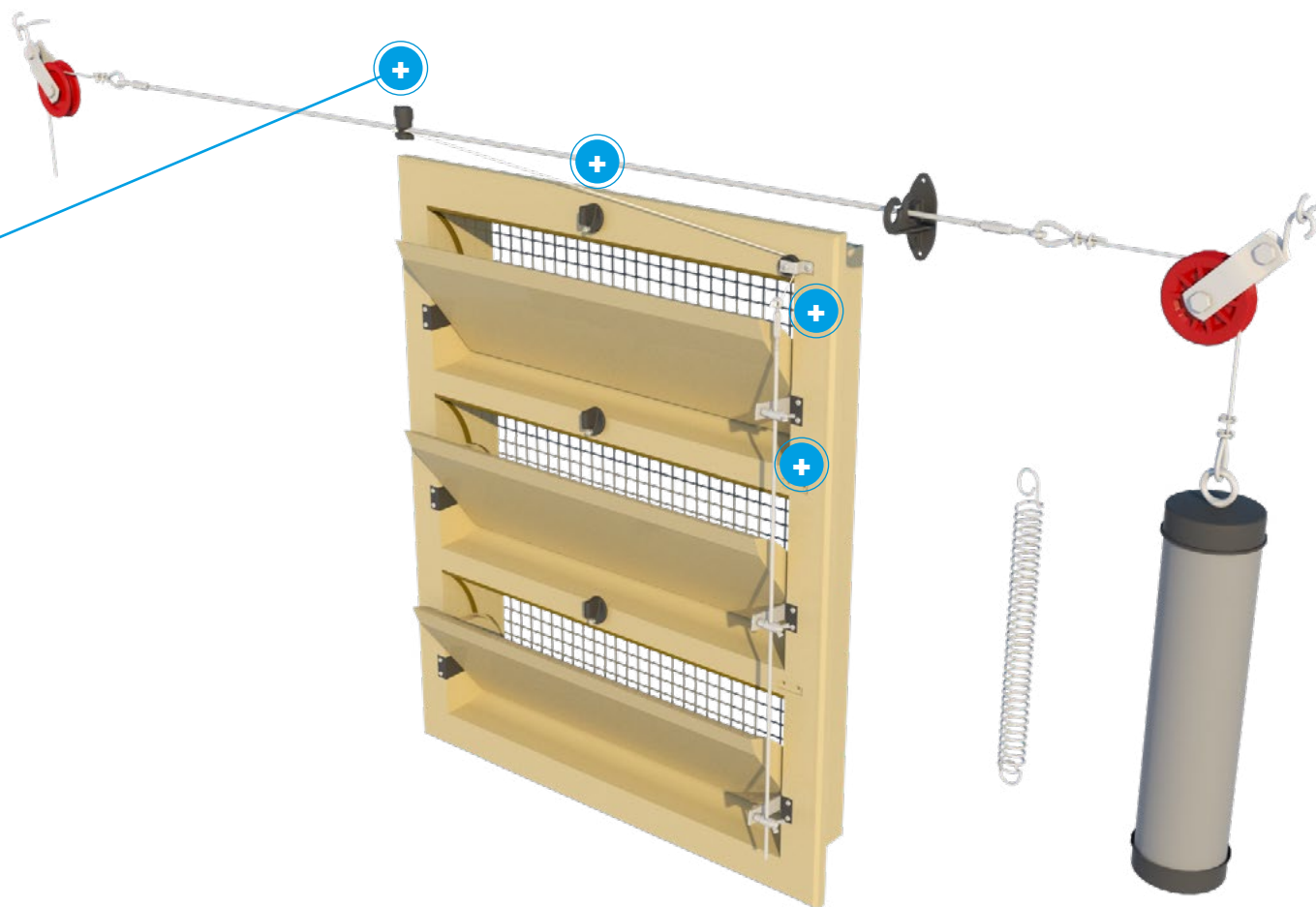

INFO

DATASHEET

ASSEMBLY

MOUNTING

WORKING

MAINTENANCE



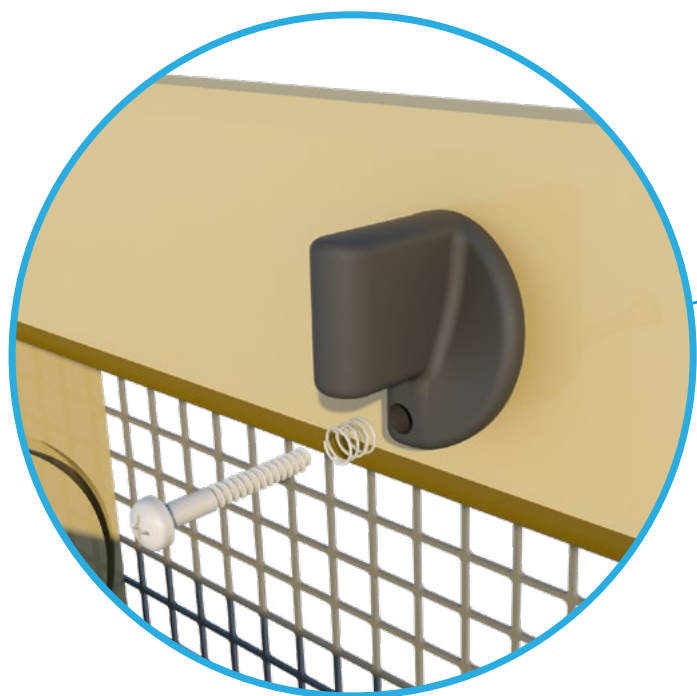

TPI-307

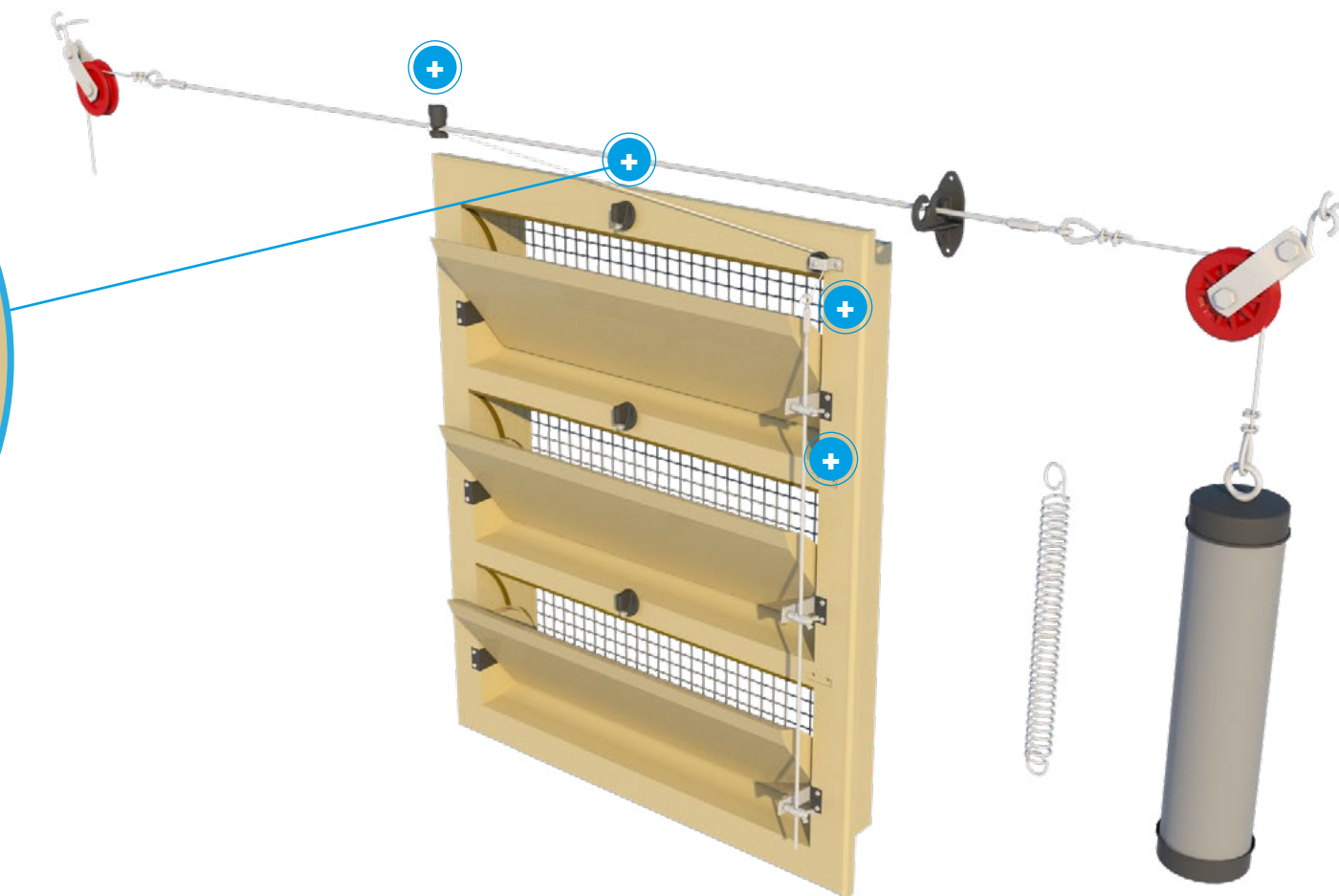

INFO

DATASHEET

ASSEMBLY

MOUNTING

WORKING

MAINTENANCE



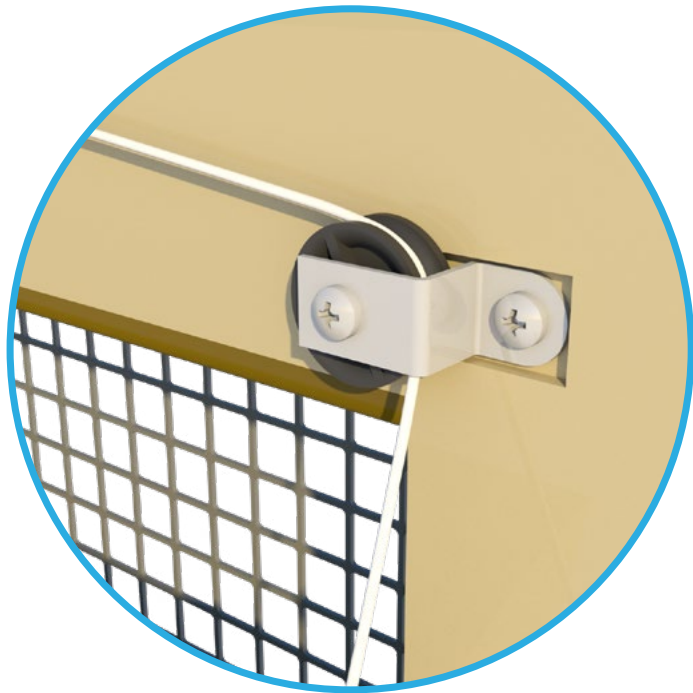

TPI-219

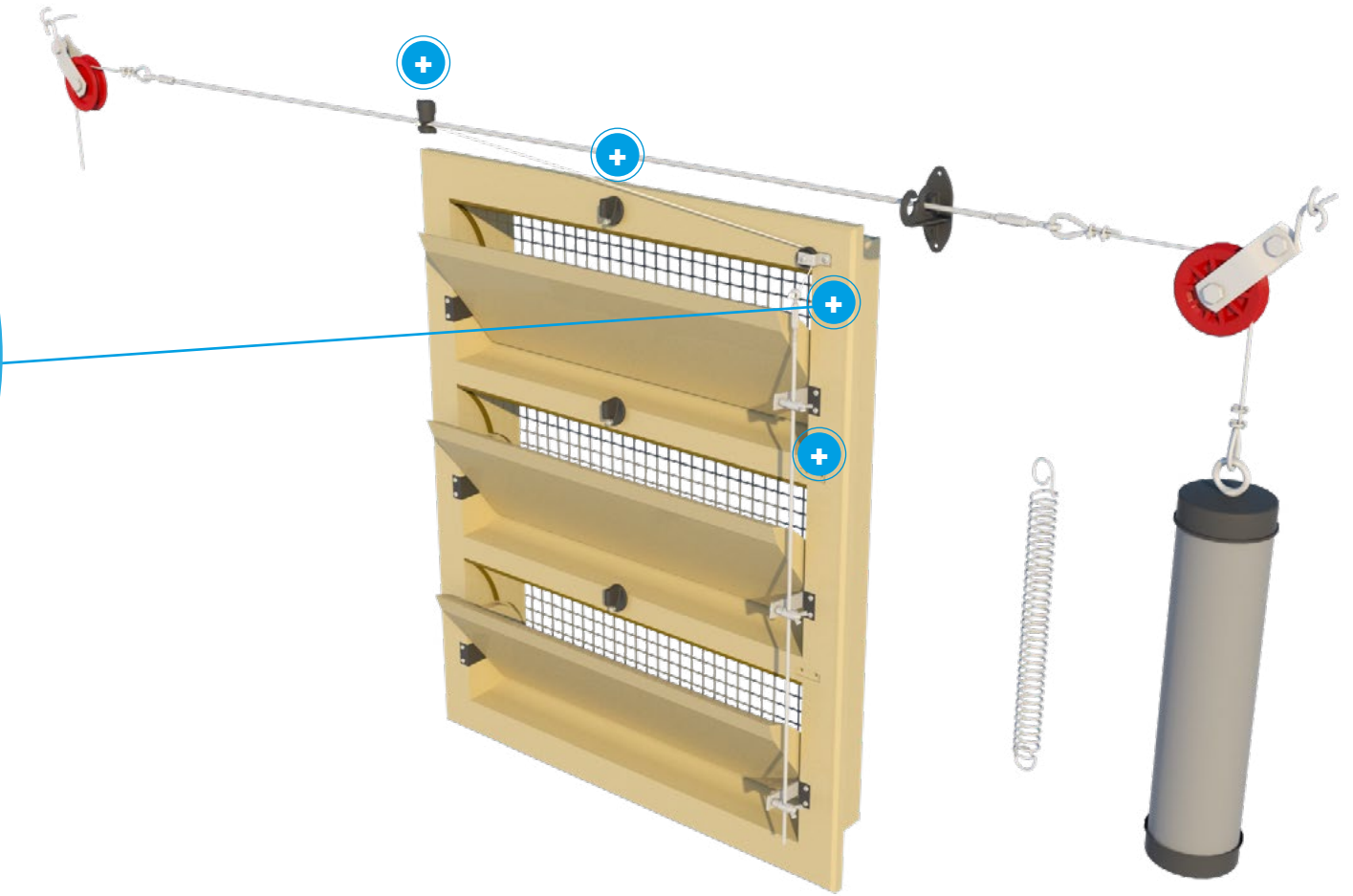

INFO

DATASHEET

ASSEMBLY

MOUNTING

WORKING

MAINTENANCE



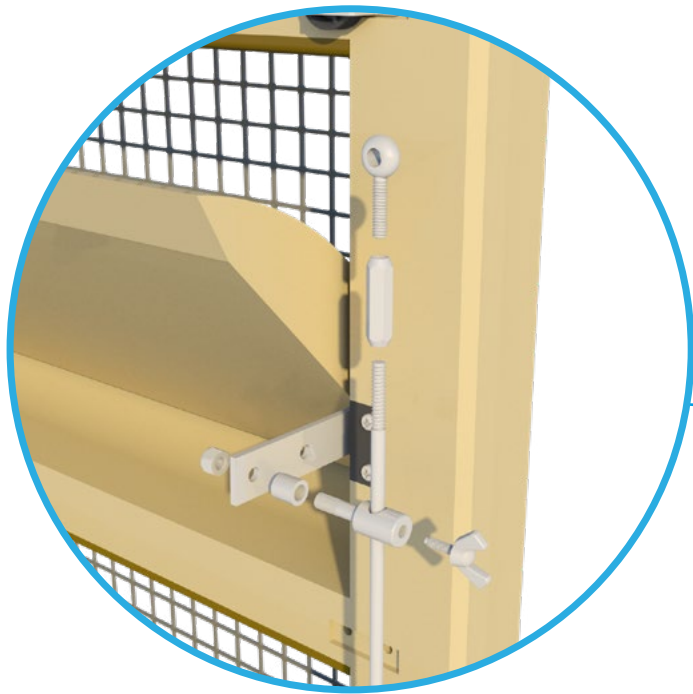

TPI-219

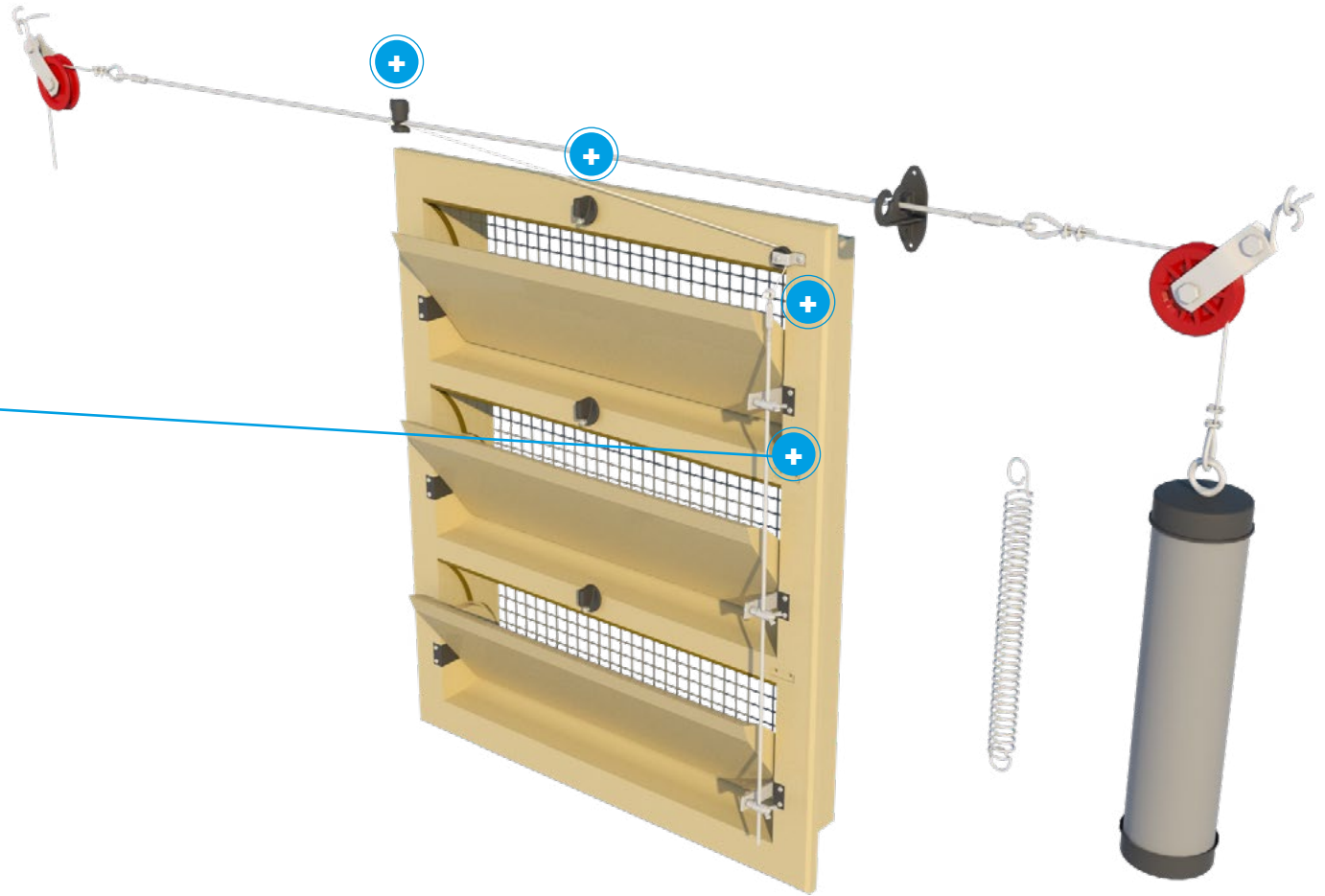

INFO

DATASHEET

ASSEMBLY

MOUNTING

WORKING

MAINTENANCE



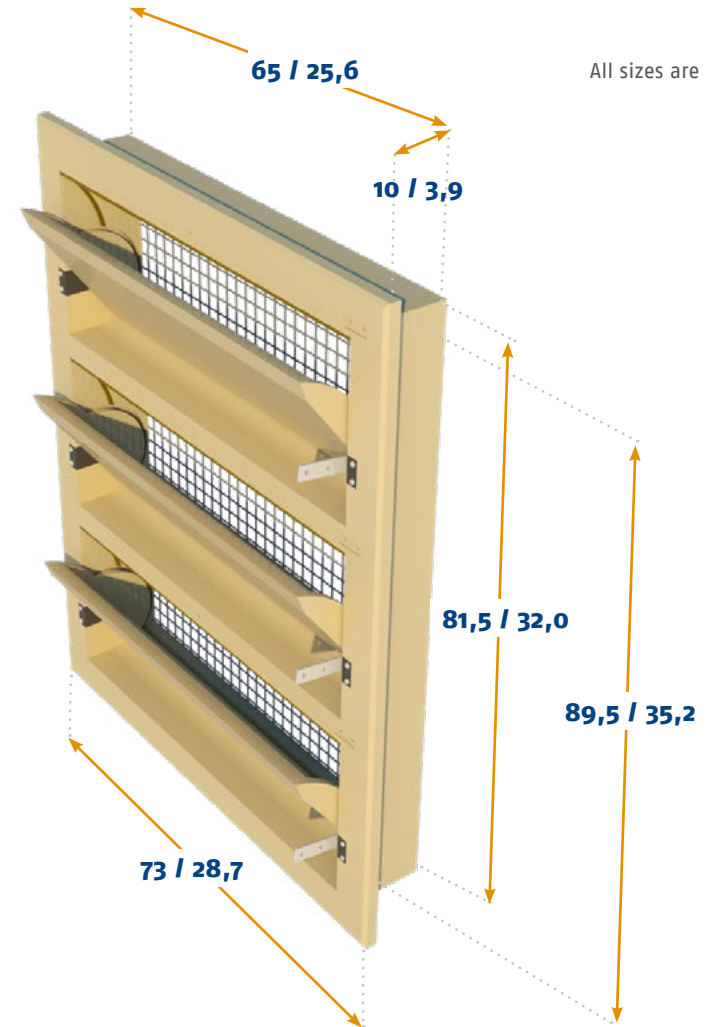
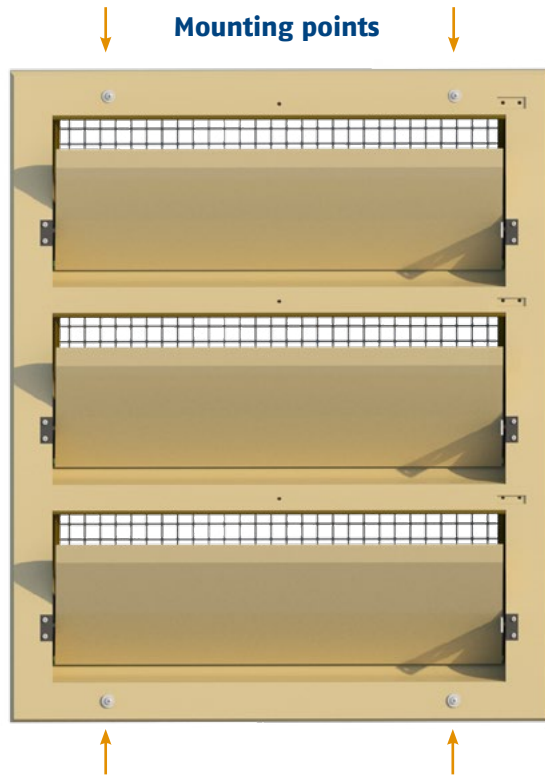

All sizes are in cm and inches

MOUNTING

Mounting type	Wall
Mounting hole size	67 cm / 26,4 inch x 83,5 cm / 32,8 inch

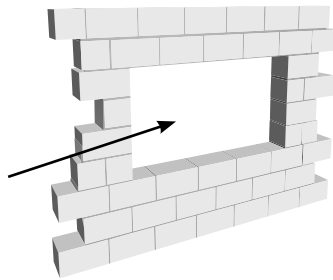

INFO

DATASHEET

ASSEMBLY

MOUNTING

WORKING

MAINTENANCE



AIR FLOW

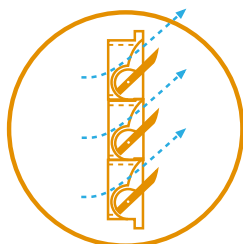

Middle hinged inlet

This middle hinged inlet is made to allow air to also flow underneath the inner flap after opening further then 35%. This helps to guide air downwards to the animals and provide a cooling effect during maximum ventilation.

Straight inner flap

This inlet is equipped with a straight inner flap. Straight flaps guide air in a straight upwards or horizontal direction, never downwards. This is ideal for houses where air should not be directed directly towards or over the animals during maximum ventilation.

Making adjustments

By using the nylon bolt and nut small adjustments can be made to make sure all inlets are closing and opening correctly. The nylon cable clamp and cord can also be used to make small adjustments.

Working with end-weights or springs

We offer two products which can be used to keep tension on the main cable. A PVC cylinder which can be filled with concrete or sand to act as end-weight, or a spring that holds tension on the cable.

Balanced set-up

When placing the motor winch or actuator we normally suggest to divide the inlets in two groups. It is preferable to place the winch or actuator in the middle to equally divide the forces on the main cable.

(see ventilation concepts page for an example)

Use of closing catches

The closing catch on the inlet can be used to permanently close inlets for example during pre-heating. The closing catches can also be used to close certain inlets while continuing to use others. In that case the used inlets can be opened a bit further. In colder climates this can help to offer better resistance to freezing effects.

Self-closing concept

This inlet is also available as a self-closing version. See the ventilation concepts page for more information.

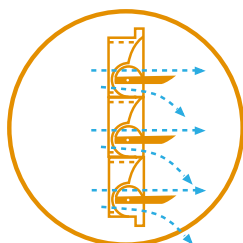

INFO

DATASHEET

ASSEMBLY

MOUNTING

WORKING

MAINTENANCE



145-FG

This inlet has a flange on the backside of the house so it can be built onto the wall instead of being built in the wall. With a middle hinged inner valve the air will be divided and also flows underneath the valve when it is opened over 35%.

The inlet is controlled by means of a stainless steel side arm. This inlet is executed with a curved inner valve so when it is opened for maximum ventilation air is also guide downwards to the animals.

(also available in self-closing version. See the ventilation concepts page for more information)

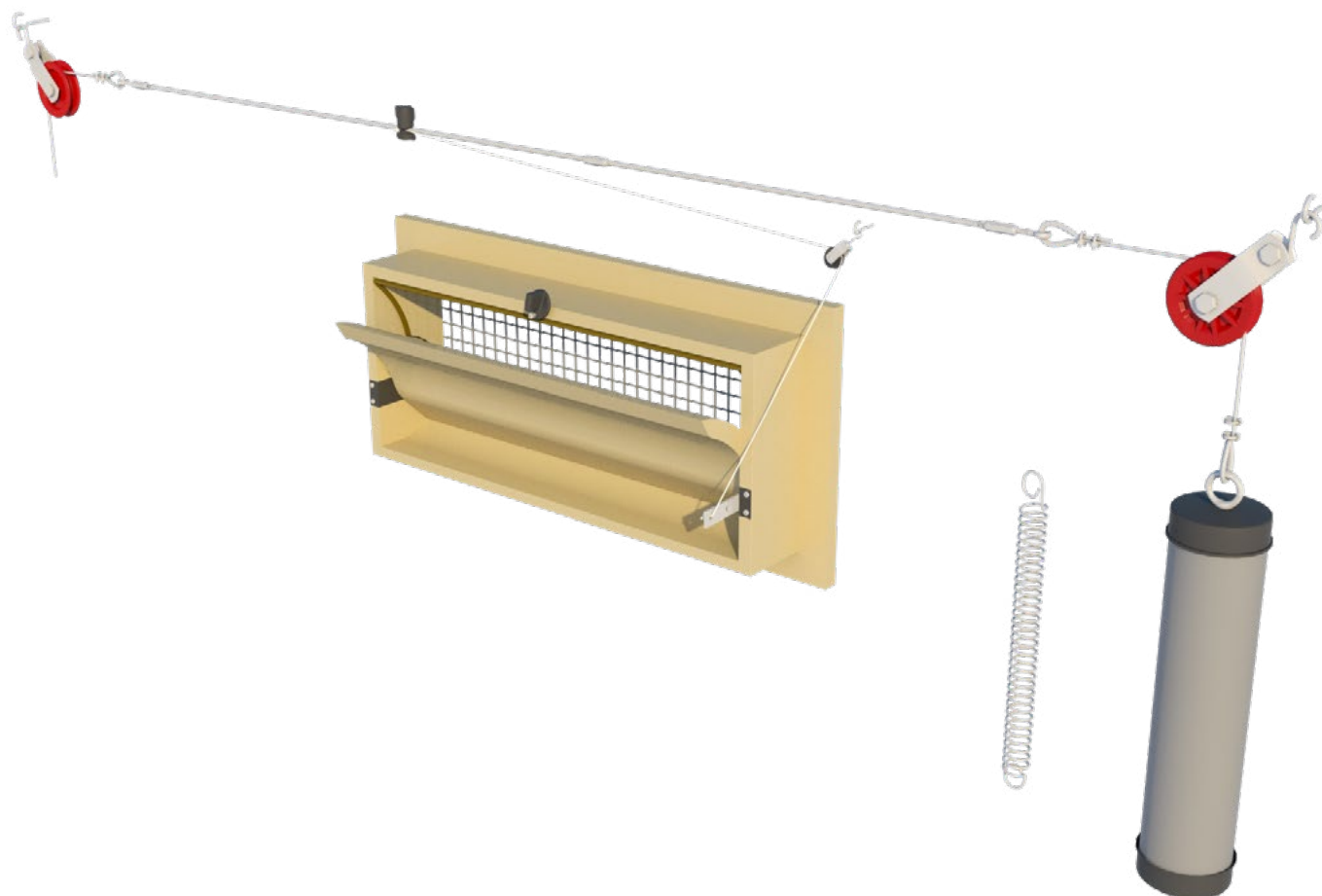

INFO

DATASHEET

ASSEMBLY

MOUNTING

WORKING

MAINTENANCE





145-FG DATASHEET



CAPACITY

Model	m ³ /h @ 10 Pa	m ³ /h @ 20 Pa	m ³ /h @ 40 Pa
145-FG	1450	2050	2900
	cfm @ 0.05 inH ₂ O	cfm @ 0.1 inH ₂ O	cfm @ 0.15 inH ₂ O
	954	1346	1648

INFORMATION

Run	11 cm / 4.3 inch
Force	2 kg / 19.6 Newton
Number / pallet (1,20 x 0,80 x 2,40m / 47 x 31,5 x 94,5inch)	52
Weight / per inlet	2,2 kg / 4.9 lbs
Volume / per box	26

OPTIONAL ACCESSORIES

TPI-101	Wire mesh galvanized
TPI-109	Wire mesh synthetic
TPI-204	Connection set
TPI-307	Closing catch + spring
TPI-408	Hanging pulley
TPI-702	Counter flange for inlets in 135/145-series

AIR FLOW

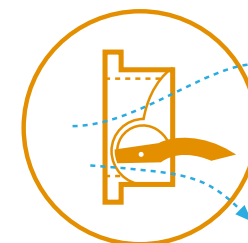
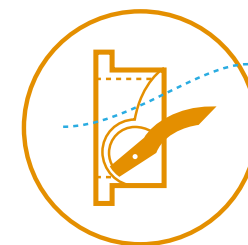

INFO

DATASHEET

ASSEMBLY

MOUNTING

WORKING

MAINTENANCE





TPI-204C

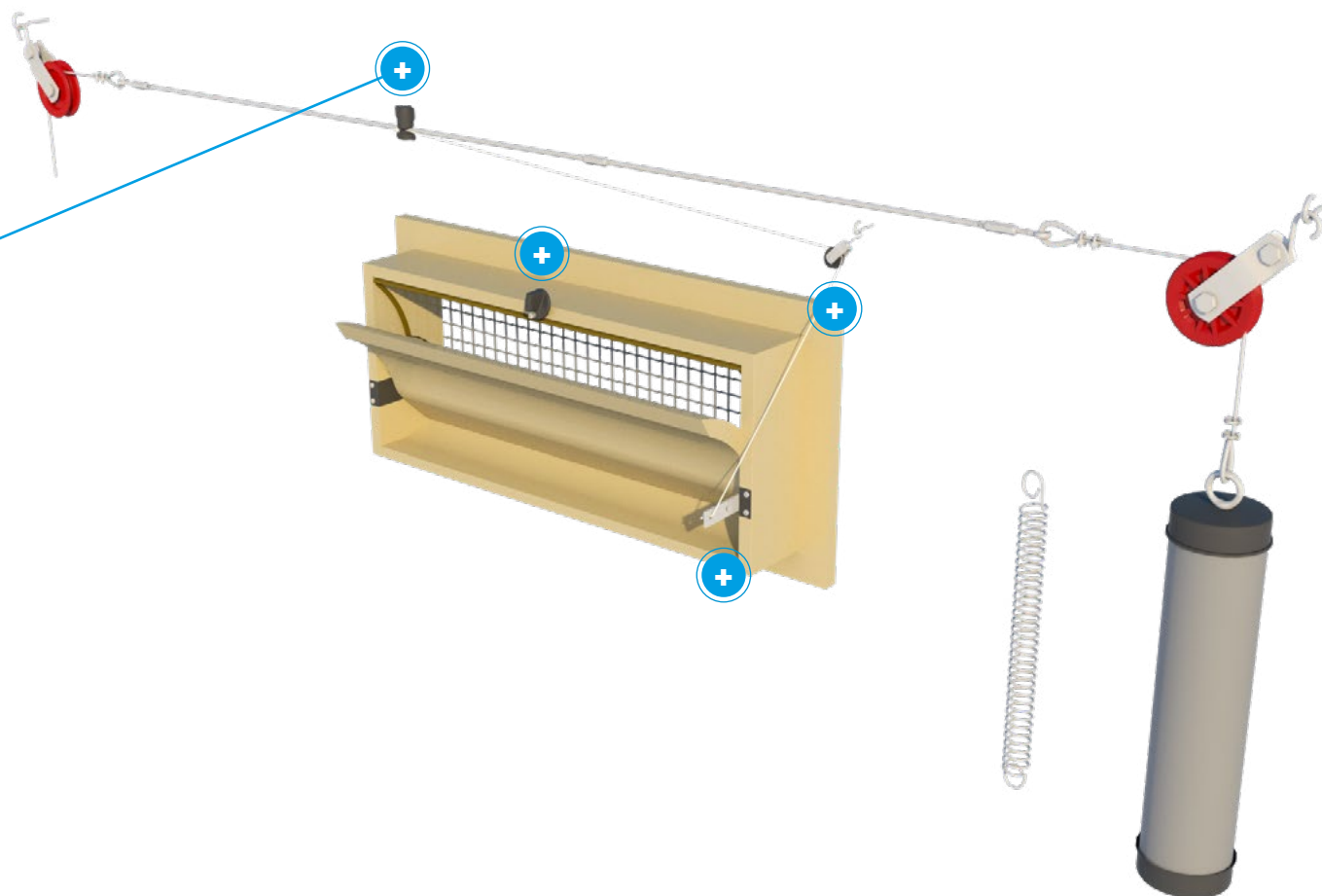

INFO

DATASHEET

ASSEMBLY

MOUNTING

WORKING

MAINTENANCE



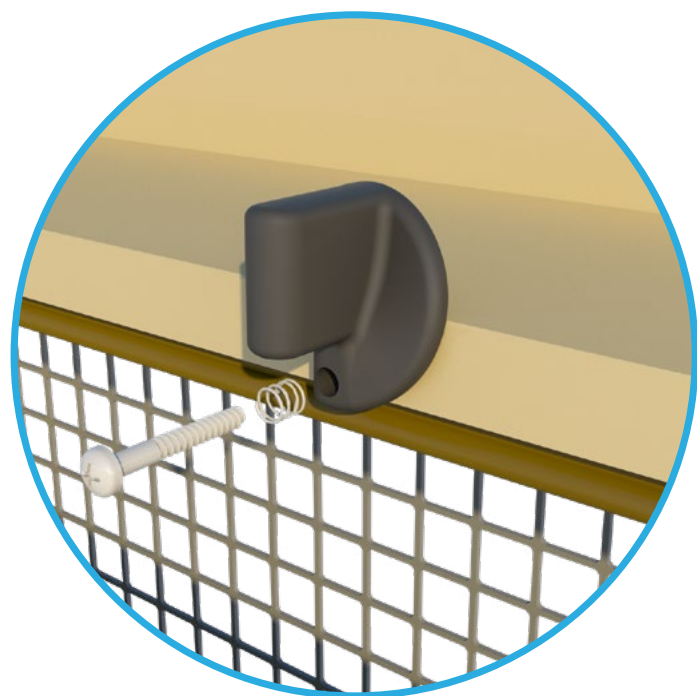

TPI-307

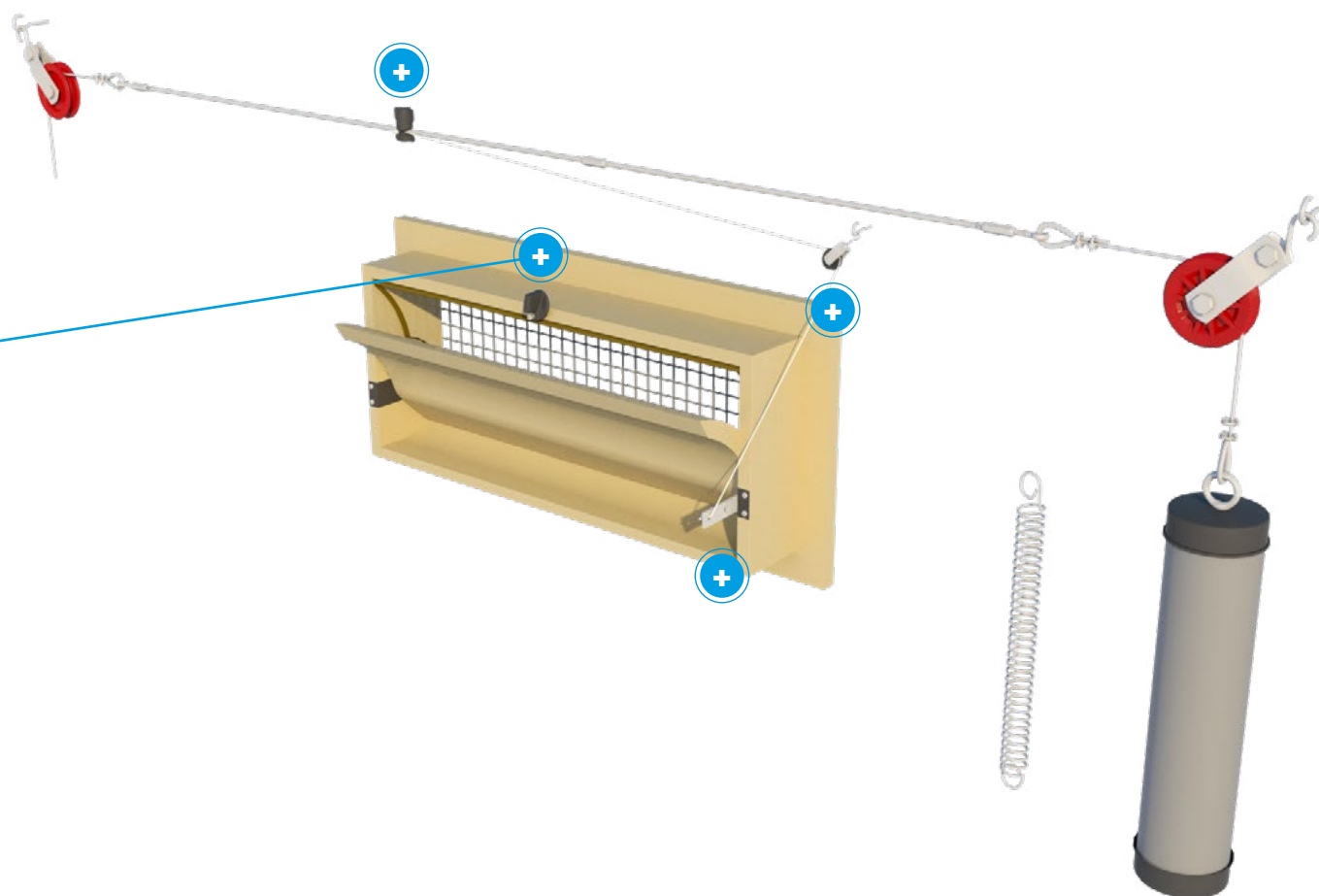



TPI-408

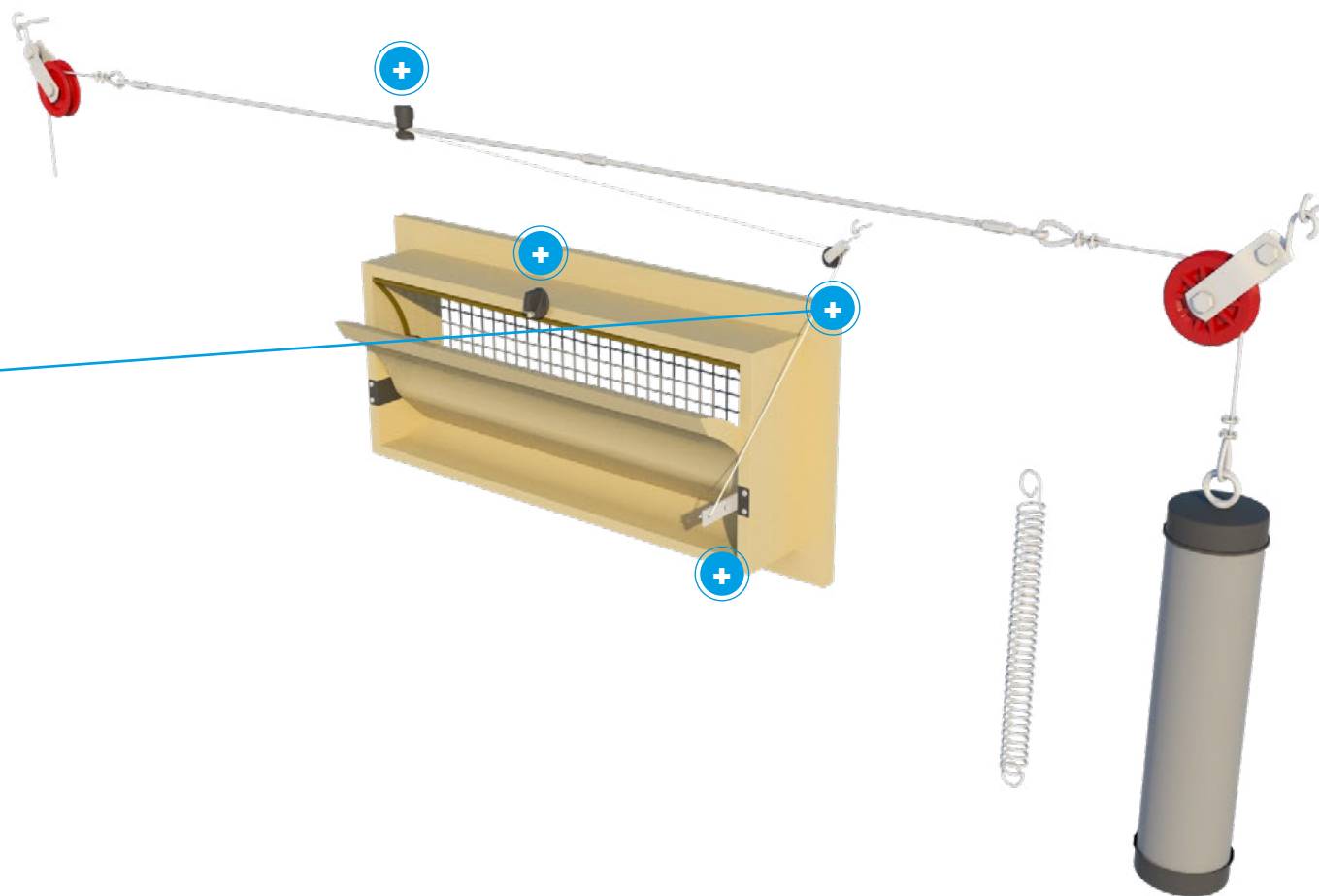

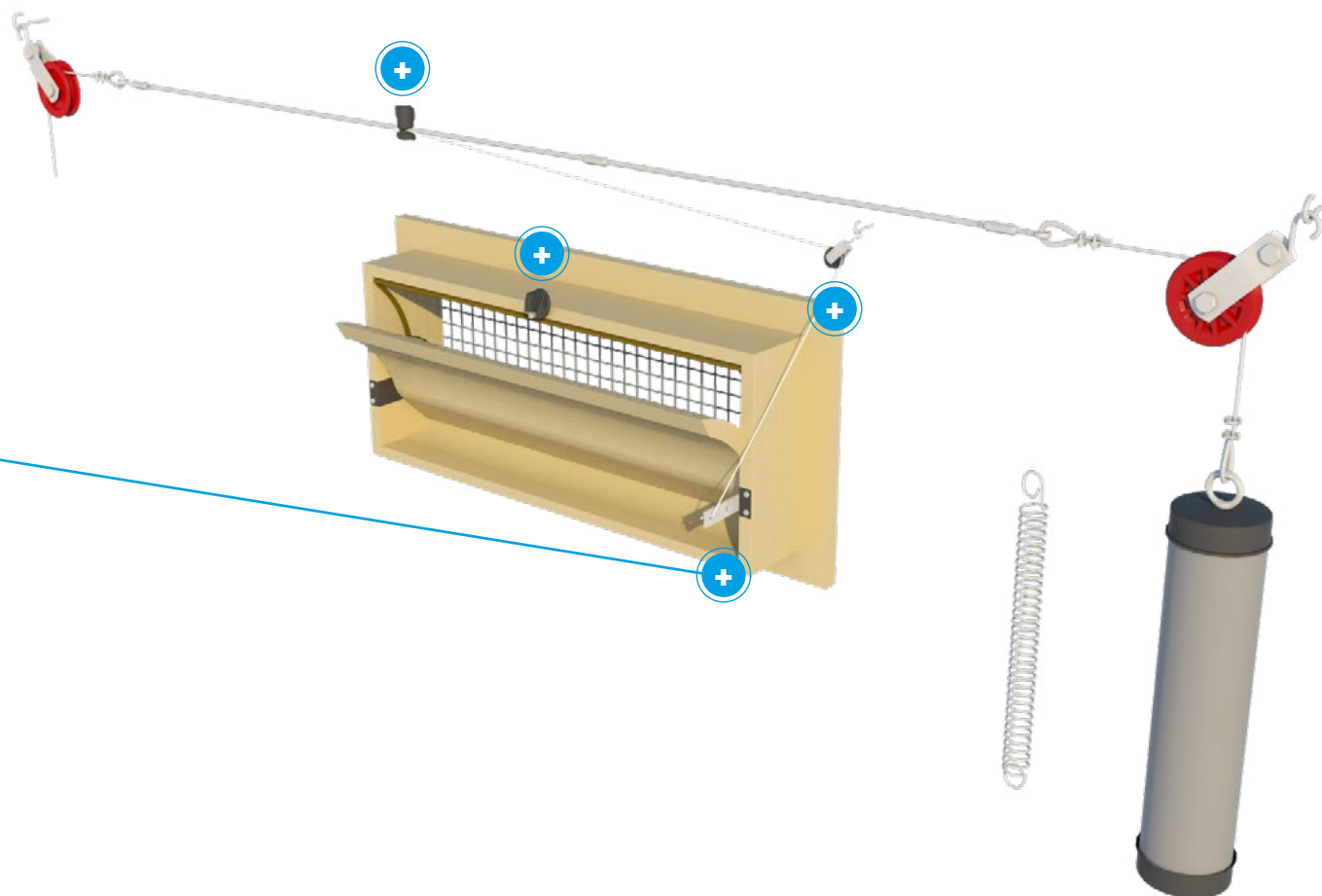
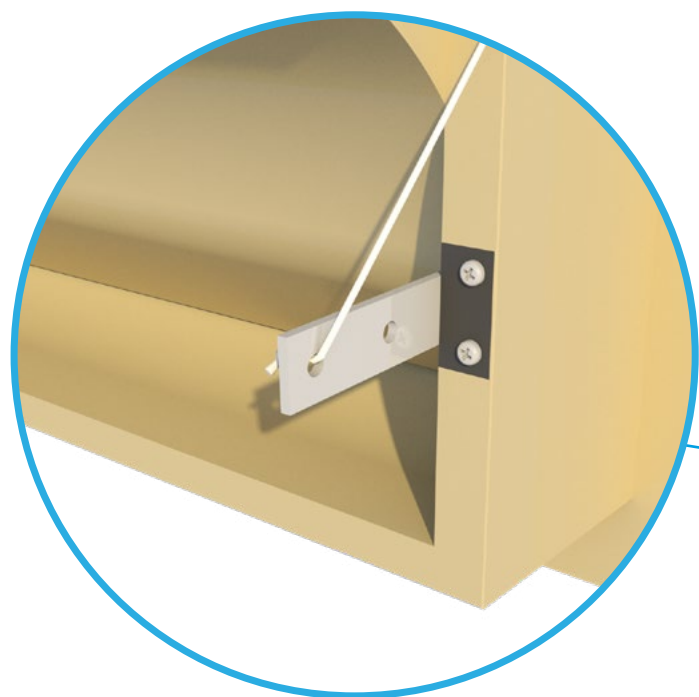

All sizes are in cm and inches

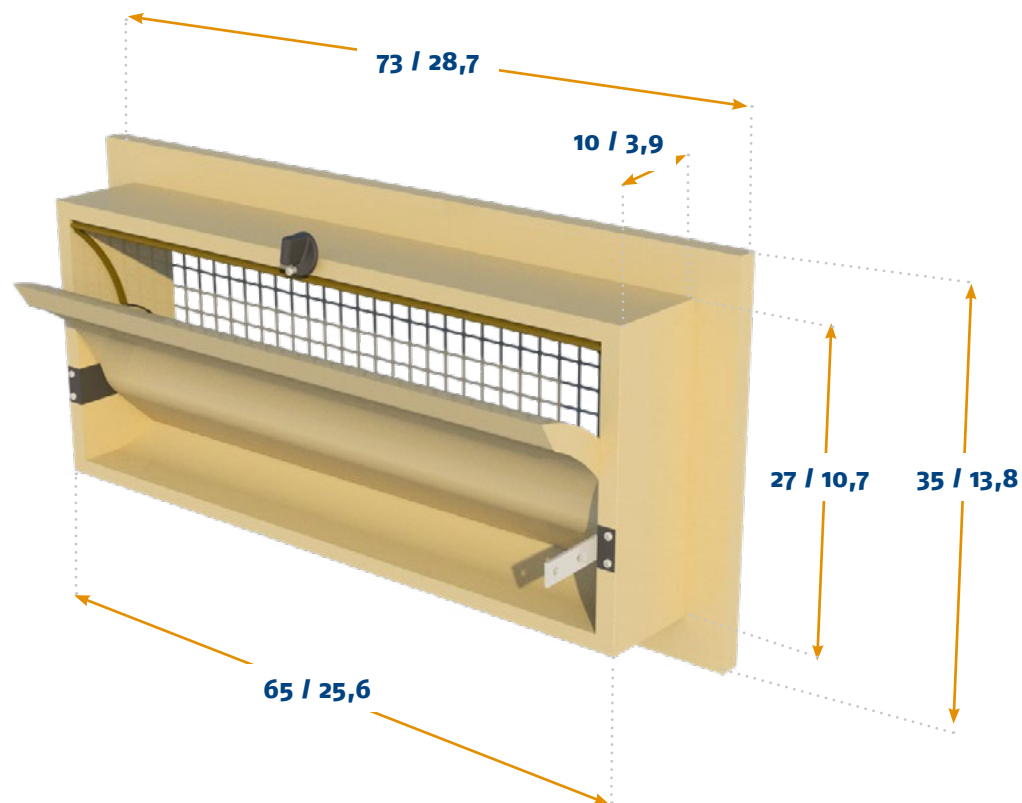
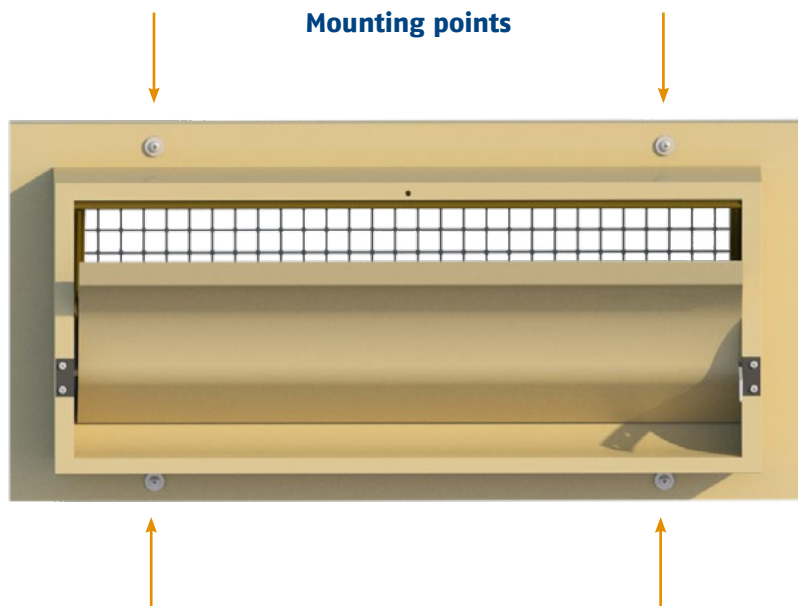

MOUNTING

Mounting type	Wall
Max. hole size in wall	67 cm / 26,4 inch x 29 cm / 11,5 inch

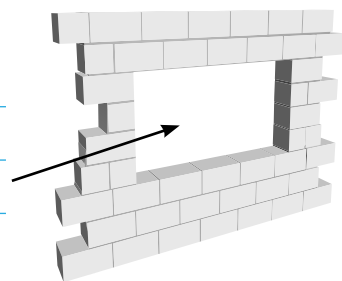

INFO

DATASHEET

ASSEMBLY

MOUNTING

WORKING

MAINTENANCE



AIR FLOW

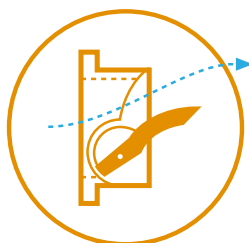

Middle hinged inlet

This middle hinged inlet is made to allow air to also flow underneath the inner flap after opening further then 35%. This helps to guide air downwards to the animals and provide a cooling effect during maximum ventilation.

Curved inner flap

This inlet is equipped with a curved inner flap. Curved flaps guide the air upwards during minimum ventilation, but also downwards after a certain point of opening. This is ideal for houses where air should be directed directly towards or over the animals during maximum ventilation.

Working with end-weights or springs

We offer two products which can be used to keep tension on the main cable. A PVC cylinder which can be filled with concrete or sand to act as end-weight, or a spring that holds tension on the cable.

Balanced set-up

When placing the motor winch or actuator we normally suggest to divide the inlets in two groups. It is preferable to place the winch or actuator in the middle to equally divide the forces on the main cable.

(see ventilation concepts page for an example)

Use of closing catches

The closing catch on the inlet can be used to permanently close inlets for example during pre-heating. The closing catches can also be used to close certain inlets while continuing to use others. In that case the used inlets can be opened a bit further. In colder climates this can help to offer better resistance to freezing effects.

Self-closing concept

This inlet is also available as a self-closing version. See the ventilation concepts page for more information.

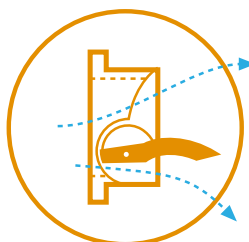

INFO

DATASHEET

ASSEMBLY

MOUNTING

WORKING

MAINTENANCE



145-FR

This inlet has a flange on the backside of the house so it can be built onto the wall instead of being built in the wall. With a middle hinged inner valve the air will be divided and also flows underneath the valve when it is opened over 35%. The inlet is controlled by means of a stainless steel side arm. This inlet is executed with a straight inner valve so when it is opened for maximum ventilation air is not guided downwards to the animals.

(also available in self-closing version. See the ventilation concepts page for more information)

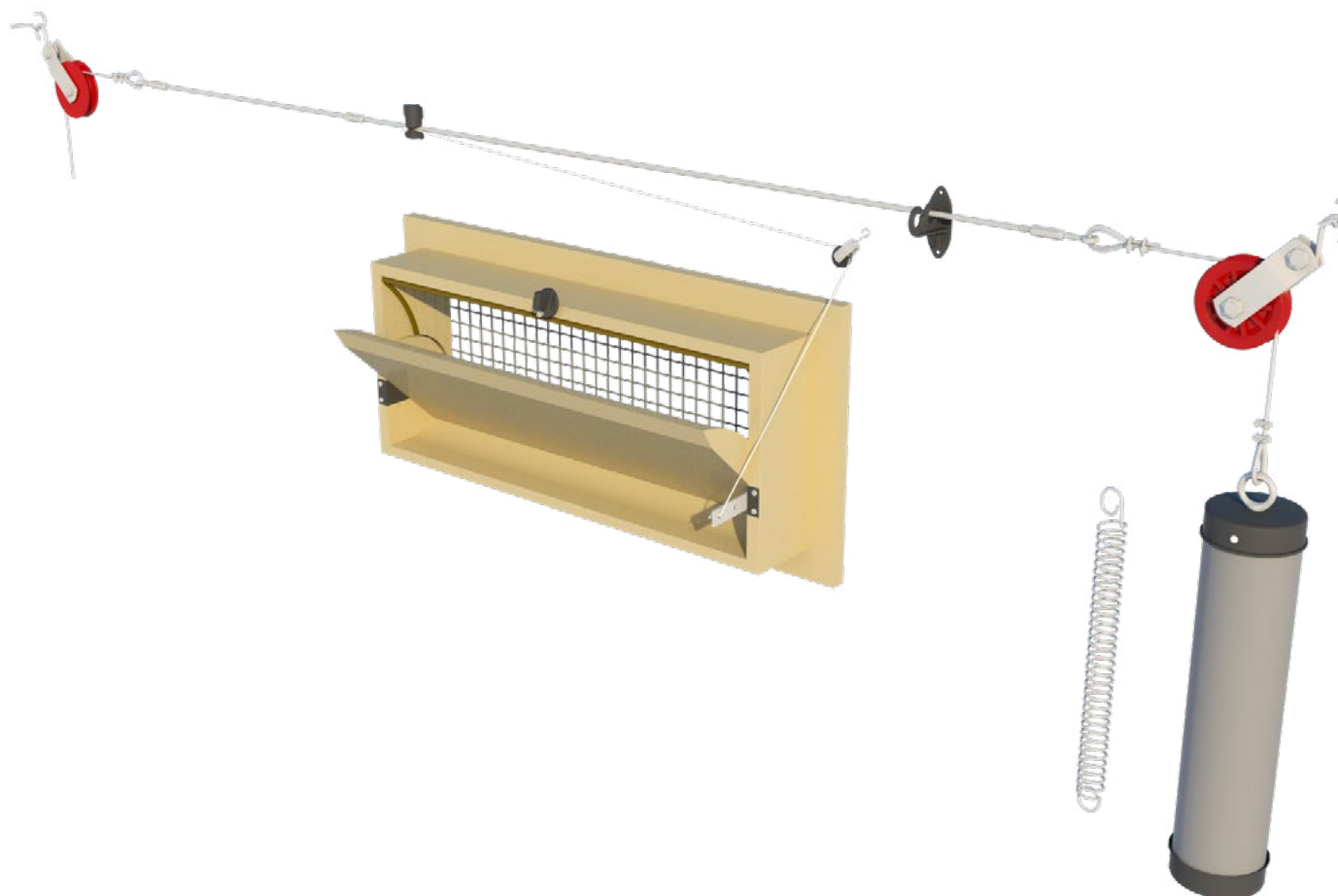

INFO

DATASHEET

ASSEMBLY

MOUNTING

WORKING

MAINTENANCE



CAPACITY

Model	m ³ /h @ 10 Pa	m ³ /h @ 20 Pa	m ³ /h @ 40 Pa
145-FR	1450	2050	2900
	cfm @ 0.05 inH ₂ O	cfm @ 0.1 inH ₂ O	cfm @ 0.15 inH ₂ O
	954	1346	1648

INFORMATION

Run	11 cm / 4.3 inch
Force	2 kg / 19.6 Newton
Number / pallet (1,20 x 0,80 x 2,40m / 47 x 31,5 x 94,5inch)	52
Weight / per inlet	2,2 kg / 4.9 lbs
Volume / per box	26

OPTIONAL ACCESSORIES

TPI-101	Wire mesh galvanized
TPI-109	Wire mesh synthetic
TPI-204c	Connection set
TPI-307	Closing catch + spring
TPI-408	Hanging pulley
TPI-702	Counter flange for inlets in 135/145-series

AIR FLOW

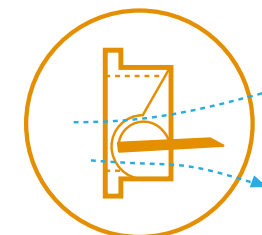
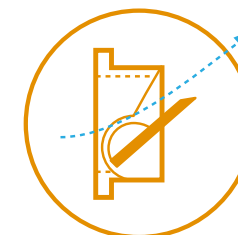
[INFO](#)
[DATASHEET](#)
[ASSEMBLY](#)
[MOUNTING](#)
[WORKING](#)
[MAINTENANCE](#)



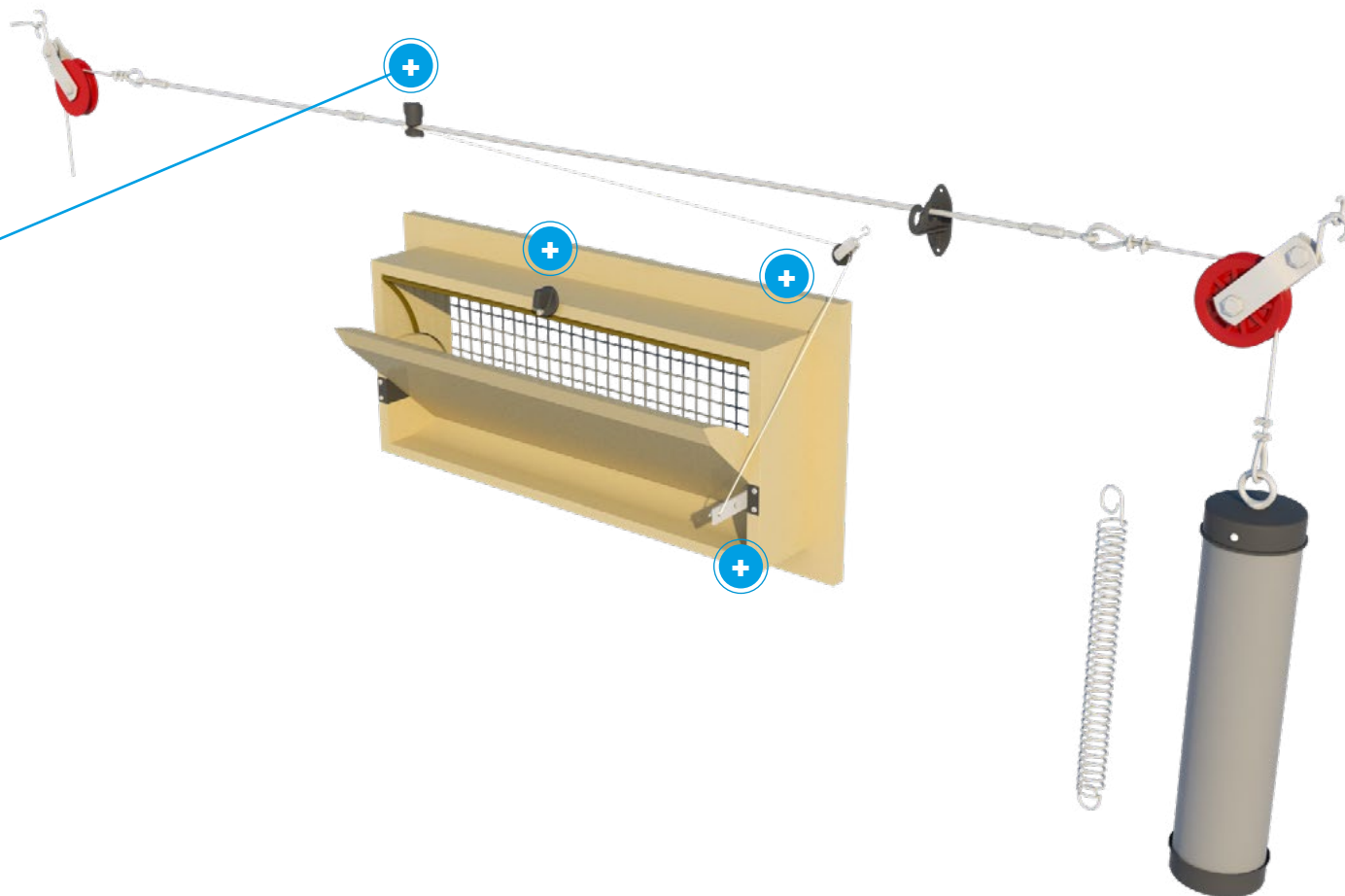

TPI-204C



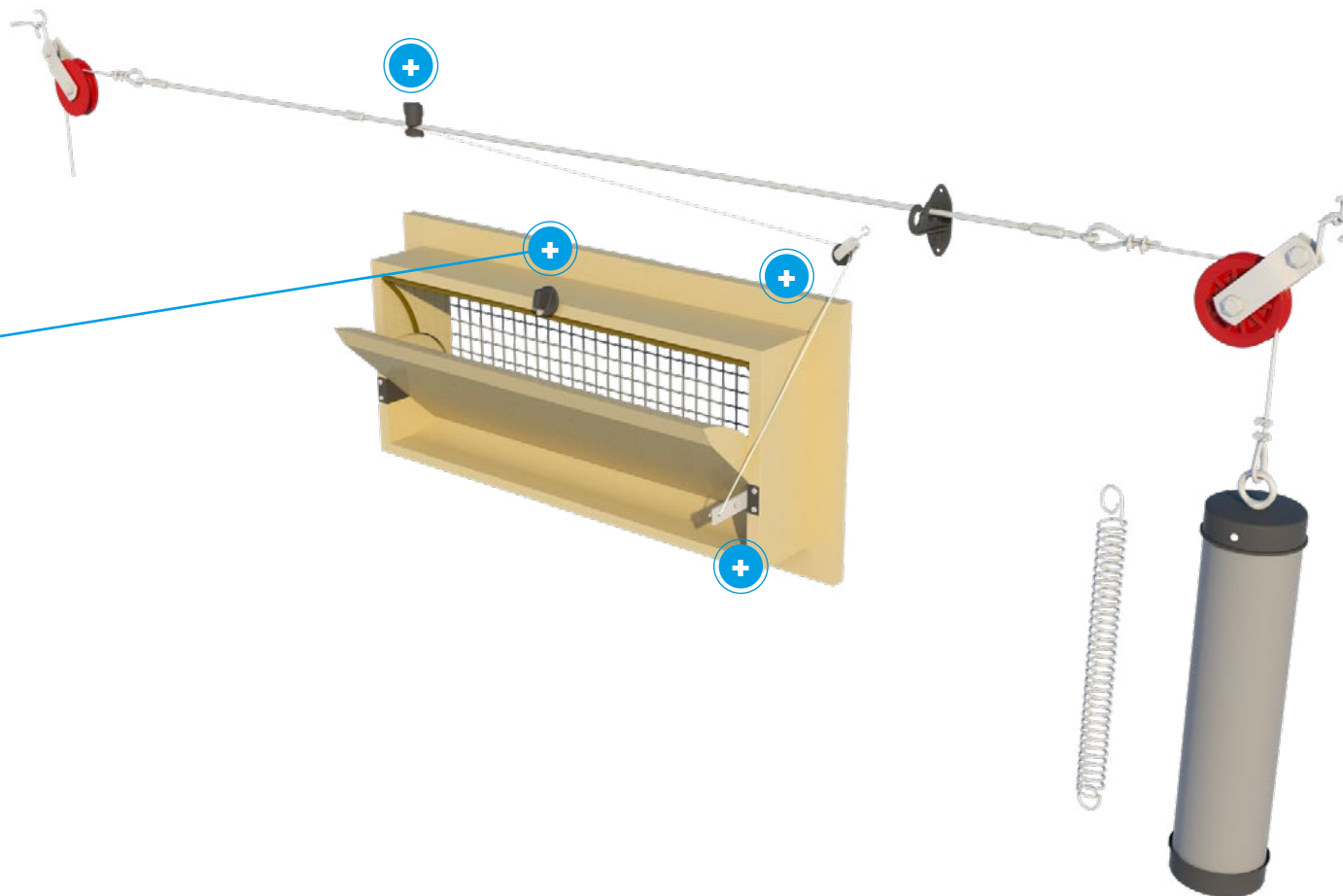

TPI-307

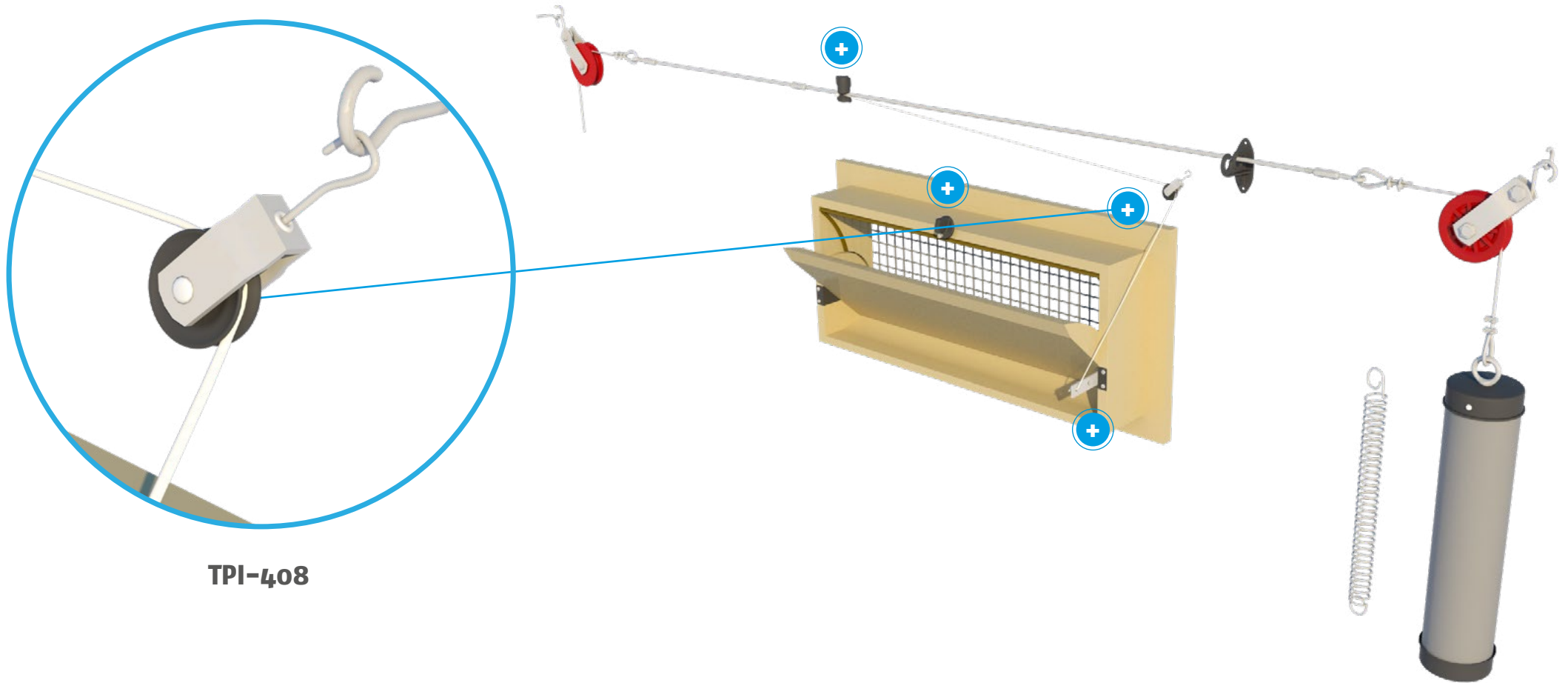



TPI-408

INFO

DATASHEET

ASSEMBLY

MOUNTING

WORKING

MAINTENANCE



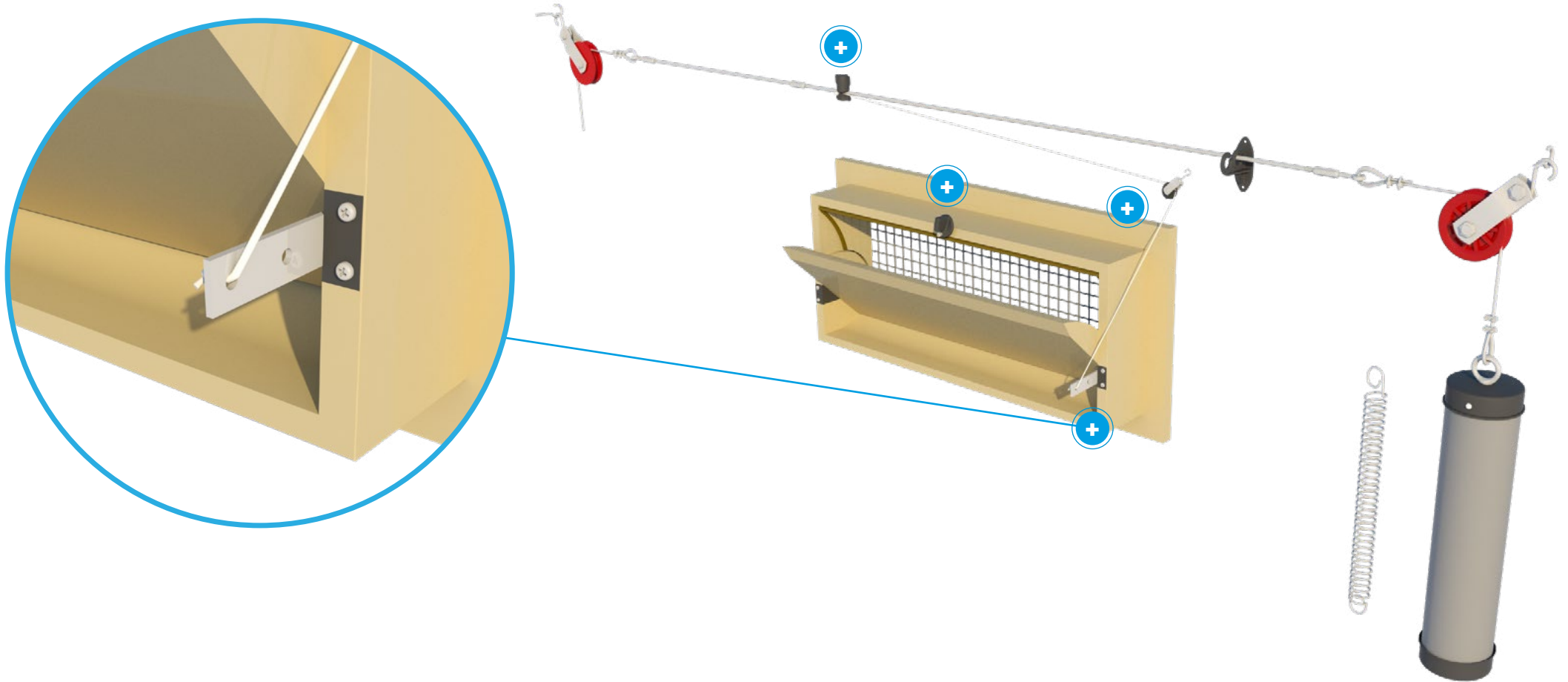

INFO

DATASHEET

ASSEMBLY

MOUNTING

WORKING

MAINTENANCE



All sizes are in cm and inches

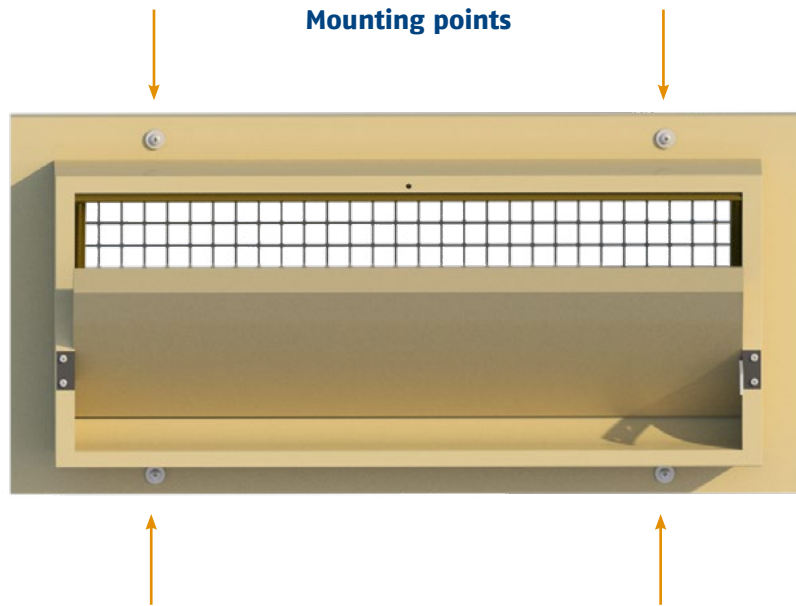

Mounting points

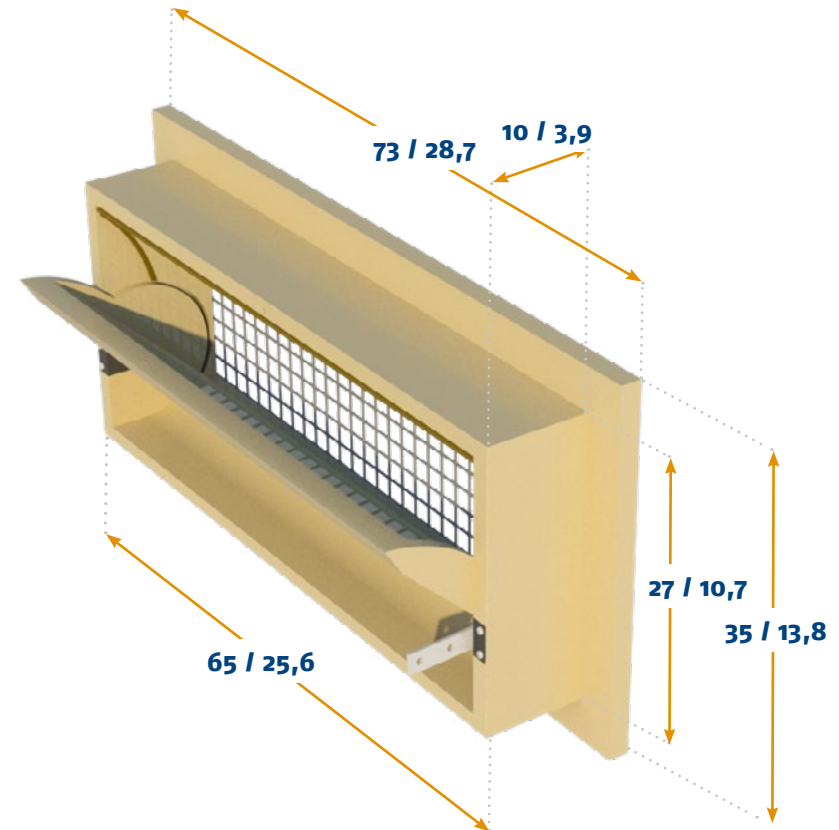

MOUNTING

Mounting type	Wall
Max. hole size in wall	67 cm / 26,4 inch x 29 cm / 10,7 inch

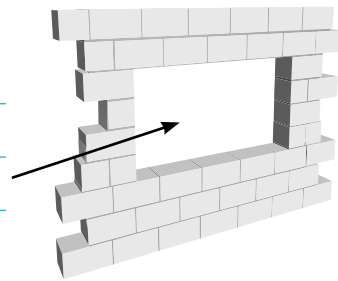

INFO

DATASHEET

ASSEMBLY

MOUNTING

WORKING

MAINTENANCE



AIR FLOW

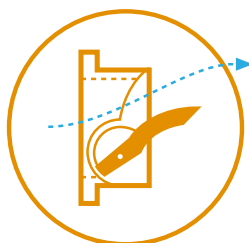

Middle hinged inlet

This middle hinged inlet is made to allow air to also flow underneath the inner flap after opening further than 35%. This helps to guide air downwards to the animals and provide a cooling effect during maximum ventilation.

Straight inner flap

This inlet is equipped with a straight inner flap. Straight flaps guide air in a straight upwards or horizontal direction, never downwards. This is ideal for houses where air should not be directed directly towards or over the animals during maximum ventilation.

Working with end-weights or springs

We offer two products which can be used to keep tension on the main cable. A PVC cylinder which can be filled with concrete or sand to act as end-weight, or a spring that holds tension on the cable.

Balanced set-up

When placing the motor winch or actuator we normally suggest to divide the inlets in two groups. It is preferable to place the winch or actuator in the middle to equally divide the forces on the main cable.

(see ventilation concepts page for an example)

Use of closing catches

The closing catch on the inlet can be used to permanently close inlets for example during pre-heating. The closing catches can also be used to close certain inlets while continuing to use others. In that case the used inlets can be opened a bit further. In colder climates this can help to offer better resistance to freezing effects.

Self-closing concept

This inlet is also available as a self-closing version. See the ventilation concepts page for more information.



INFO

DATASHEET

ASSEMBLY

MOUNTING

WORKING

MAINTENANCE



1800-VFG-C

This inlet is suitable mostly for poultry. With a middle hinged inner valve the air will be divided and also flows underneath the valve when it is opened over 35%. The inlet is controlled by means of a central plastic control arm. This inlet is executed with a curved inner valve so when it is opened for maximum ventilation air is also guide downwards to the animals. The square shape and slightly curved inner valve of this inlet make it especially suitable for wider houses where a farther throw of air is desirable.

(also available in self-closing version. See the ventilation concepts page for more information)

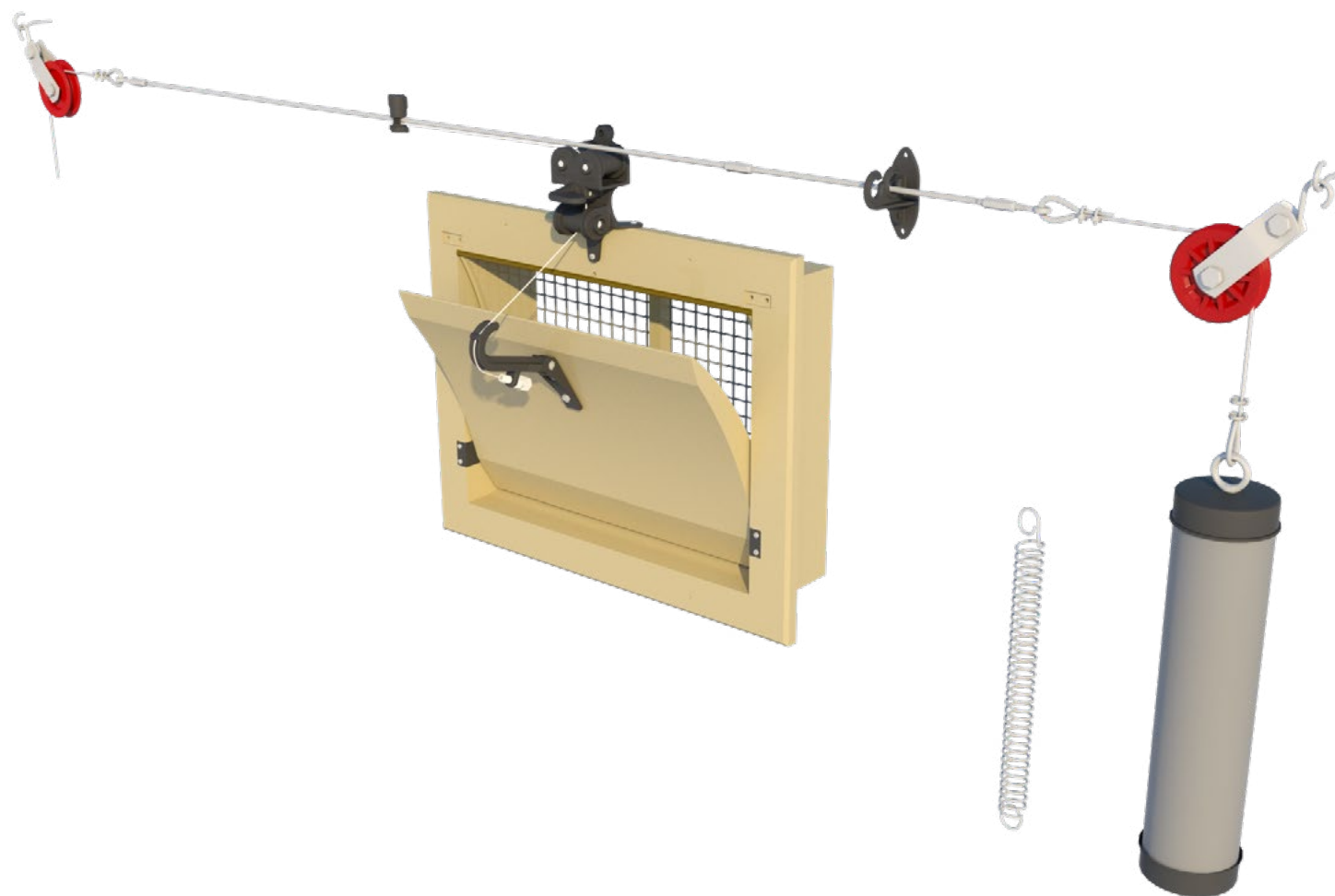

INFO

DATASHEET

ASSEMBLY

MOUNTING

WORKING

MAINTENANCE





1800-VFG-C DATASHEET



CAPACITY

Model	m ³ /h @ 10 Pa	m ³ /h @ 20 Pa	m ³ /h @ 40 Pa
1800-VFG-C	1800	2500	3600
	cfm @ 0.05 inH ₂ O	cfm @ 0.1 inH ₂ O	cfm @ 0.15 inH ₂ O
	1184	1773	2046

INFORMATION

Run	47 cm / 18.5 inch
Force	1,5 kg / 14.7 Newton
Number / pallet (1,20 x 0,80 x 2,40m / 47 x 31,5 x 94,5 inch)	46
Weight / per inlet	2,5 kg / 5.5 lbs
Volume / per box	23
Arm position	2

OPTIONAL ACCESSORIES

TPI-111	Wire mesh synthetic
TPI-204c	Connection set
TPI-423	Pulley Unit + Closing Catch

AIR FLOW

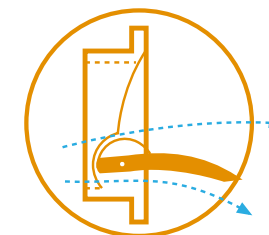
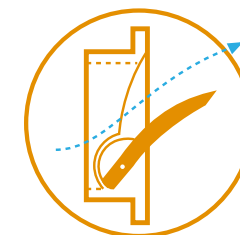

INFO

DATASHEET

ASSEMBLY

MOUNTING

WORKING

MAINTENANCE





1800-VFG-C ASSEMBLY

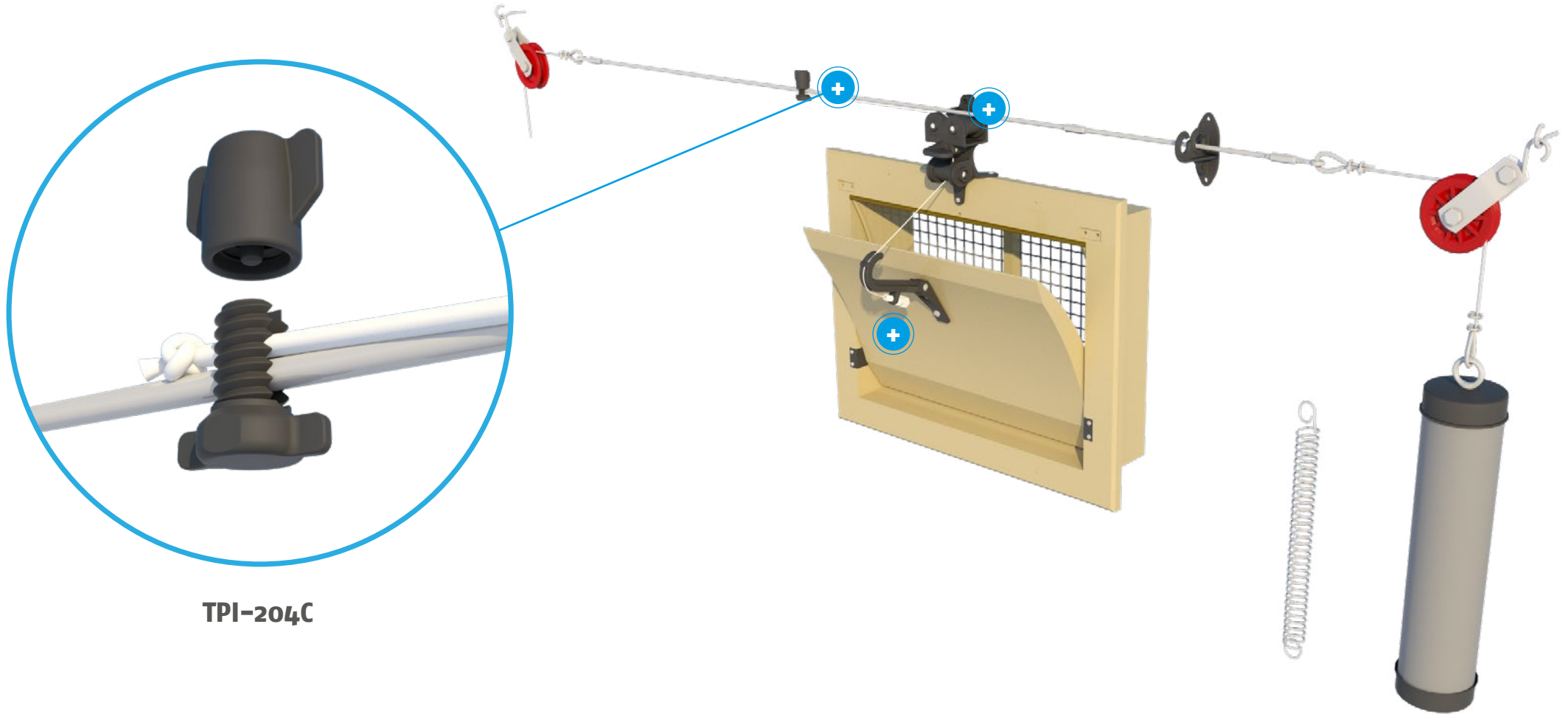

TPI-204C

INFO

DATASHEET

ASSEMBLY

MOUNTING

WORKING

MAINTENANCE



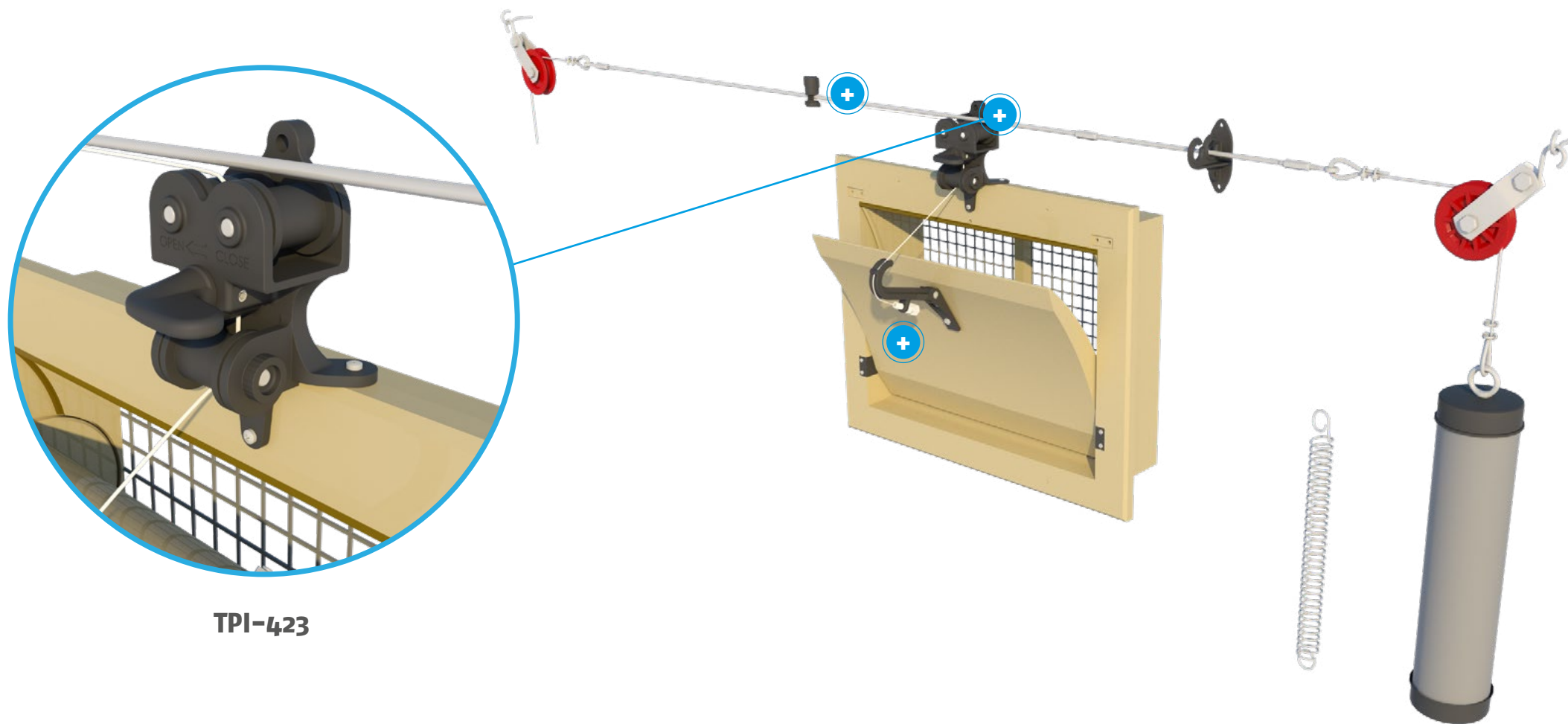

TPI-423

INFO

DATASHEET

ASSEMBLY

MOUNTING

WORKING

MAINTENANCE



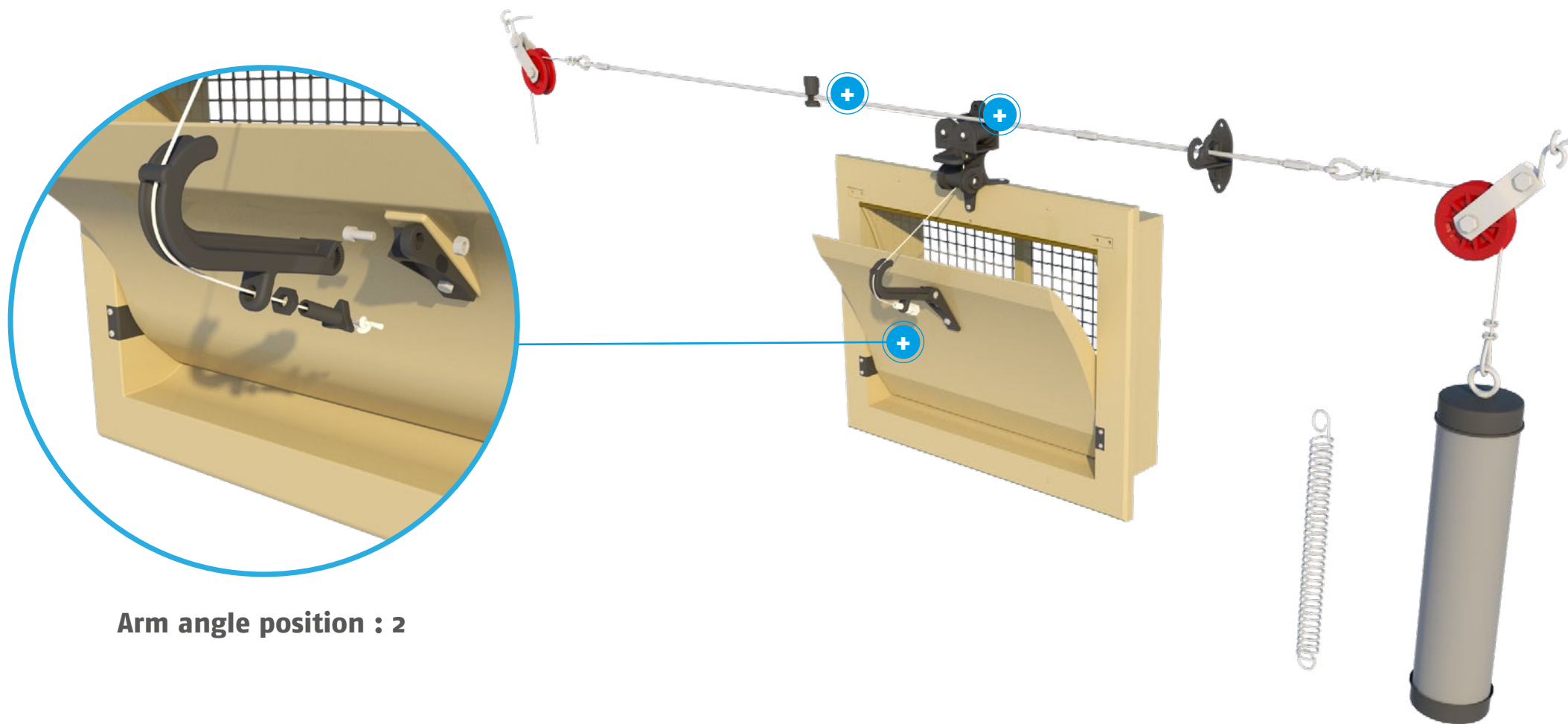

Arm angle position : 2

INFO

DATASHEET

ASSEMBLY

MOUNTING

WORKING

MAINTENANCE



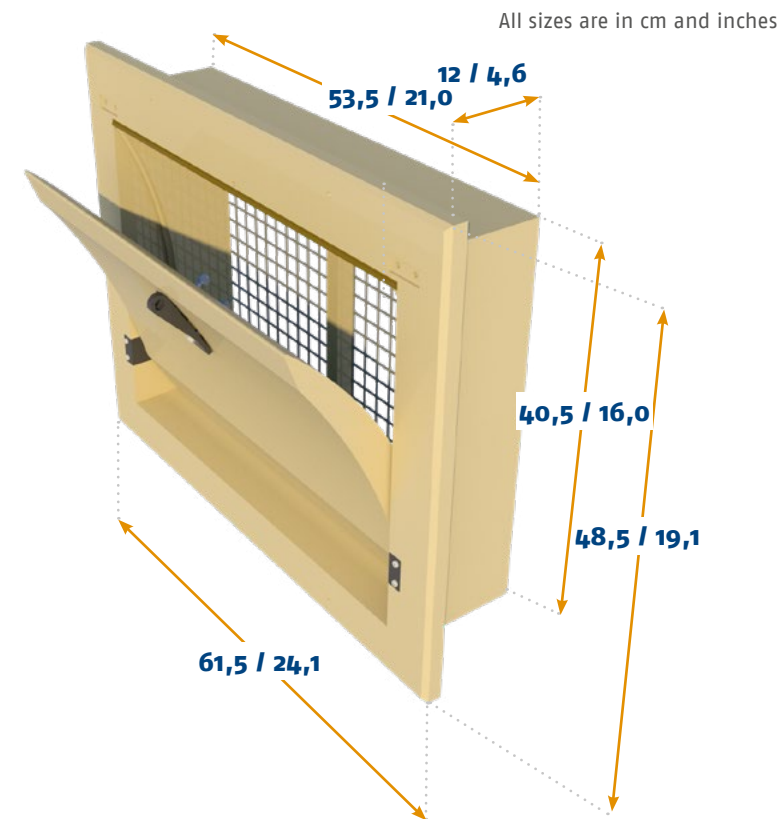
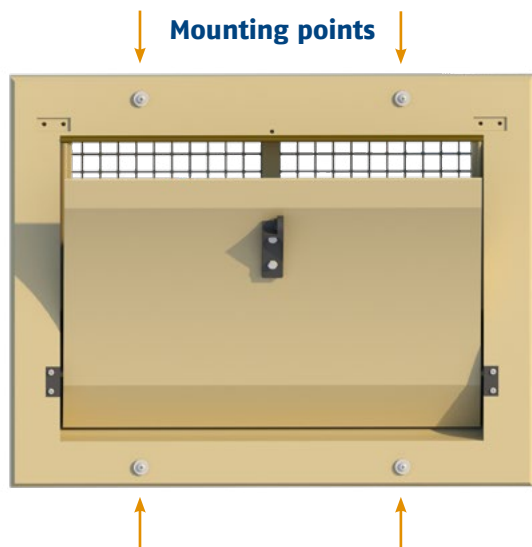

MOUNTING

Mounting type	Wall
Mounting hole size	55,5 cm / 21,8 inch x 42,5 cm / 16,8 inch

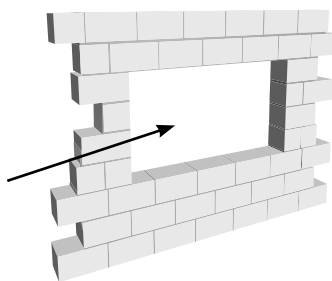

INFO

DATASHEET

ASSEMBLY

MOUNTING

WORKING

MAINTENANCE



AIR FLOW

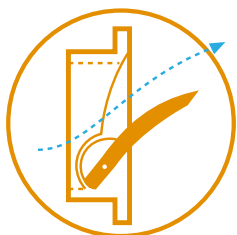

Middle hinged inlet

This middle hinged inlet is made to allow air to also flow underneath the inner flap after opening further than 35%. This helps to guide air downwards to the animals and provide a cooling effect during maximum ventilation.

Curved inner flap

This inlet is equipped with a curved inner flap. Curved flaps guide the air upwards during minimum ventilation, but also downwards after a certain point of opening. This is ideal for houses where air should be directed directly towards or over the animals during maximum ventilation.

Making adjustments

By using the nylon bolt and nut small adjustments can be made to make sure all inlets are closing and opening correctly. The nylon cable clamp and cord can also be used to make small adjustments.

Working with end-weights or springs

We offer two products which can be used to keep tension on the main cable. A PVC cylinder which can be filled with concrete or sand to act as end-weight, or a spring that holds tension on the cable.

Balanced set-up

When placing the motor winch or actuator we normally suggest to divide the inlets in two groups. It is preferable to place the winch or actuator in the middle to equally divide the forces on the main cable.

(see ventilation concepts page for an example)

Use of closing catches

The closing catch on the inlet can be used to permanently close inlets for example during pre-heating. The closing catches can also be used to close certain inlets while continuing to use others. In that case the used inlets can be opened a bit further. In colder climates this can help to offer better resistance to freezing effects.

Self-closing concept

This inlet is also available as a self-closing version. See the ventilation concepts page for more information.

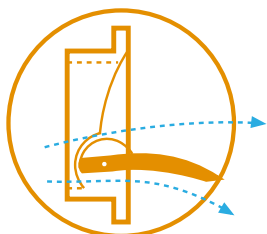

INFO

DATASHEET

ASSEMBLY

MOUNTING

WORKING

MAINTENANCE



2000-PBR-C

As an exception to our program this inlet is not made out of polyurethane but out of UV-stabilized ABS. This inlet is specially developed for areas where insulation is less relevant. The inner valve of the inlet is still insulated with an EPS panel. With a straight inner valve the air is not guided downwards to the animals during maximum ventilation. The inlet is produced in a normally closed version so it is opened by pulling the cord down, therefore the Pulley Unit is mounted on the bottom flange.

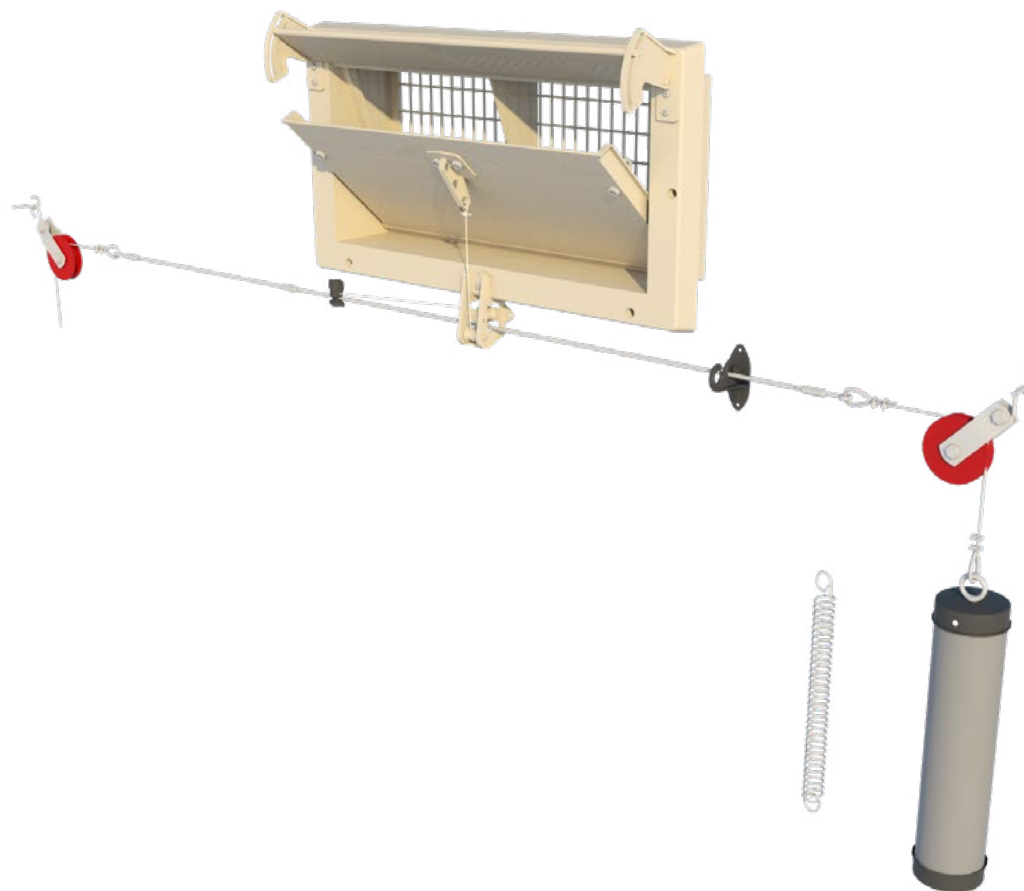

INFO

DATASHEET

ASSEMBLY

MOUNTING

WORKING

MAINTENANCE





2000-PBR-C DATASHEET



CAPACITY

Model	m ³ /h @ 10 Pa	m ³ /h @ 20 Pa	m ³ /h @ 40 Pa
2000-PBR-C	1800	2500	3600
	cfm @ 0.05 inH ₂ O	cfm @ 0.1 inH ₂ O	cfm @ 0.15 inH ₂ O
	1184	1642	2046

INFORMATION

Run	20 cm / 7.9 inch
Force	9 kg / 88.3 Newton
Number / pallet (1,20 x 0,80 x 2,40m / 47 x 31,5 x 94,5inch)	42
Weight	4,2 kg / 9.3 lbs
Volume / per box	21

OPTIONAL ACCESSORIES

TPI-204c	Connection set
TPI-420	Pulley Unit
TPI-711	Air Guide

AIR FLOW

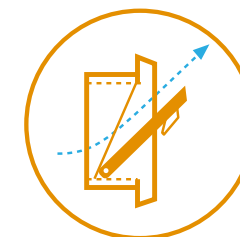
[INFO](#)[DATASHEET](#)[ASSEMBLY](#)[MOUNTING](#)[WORKING](#)[MAINTENANCE](#)

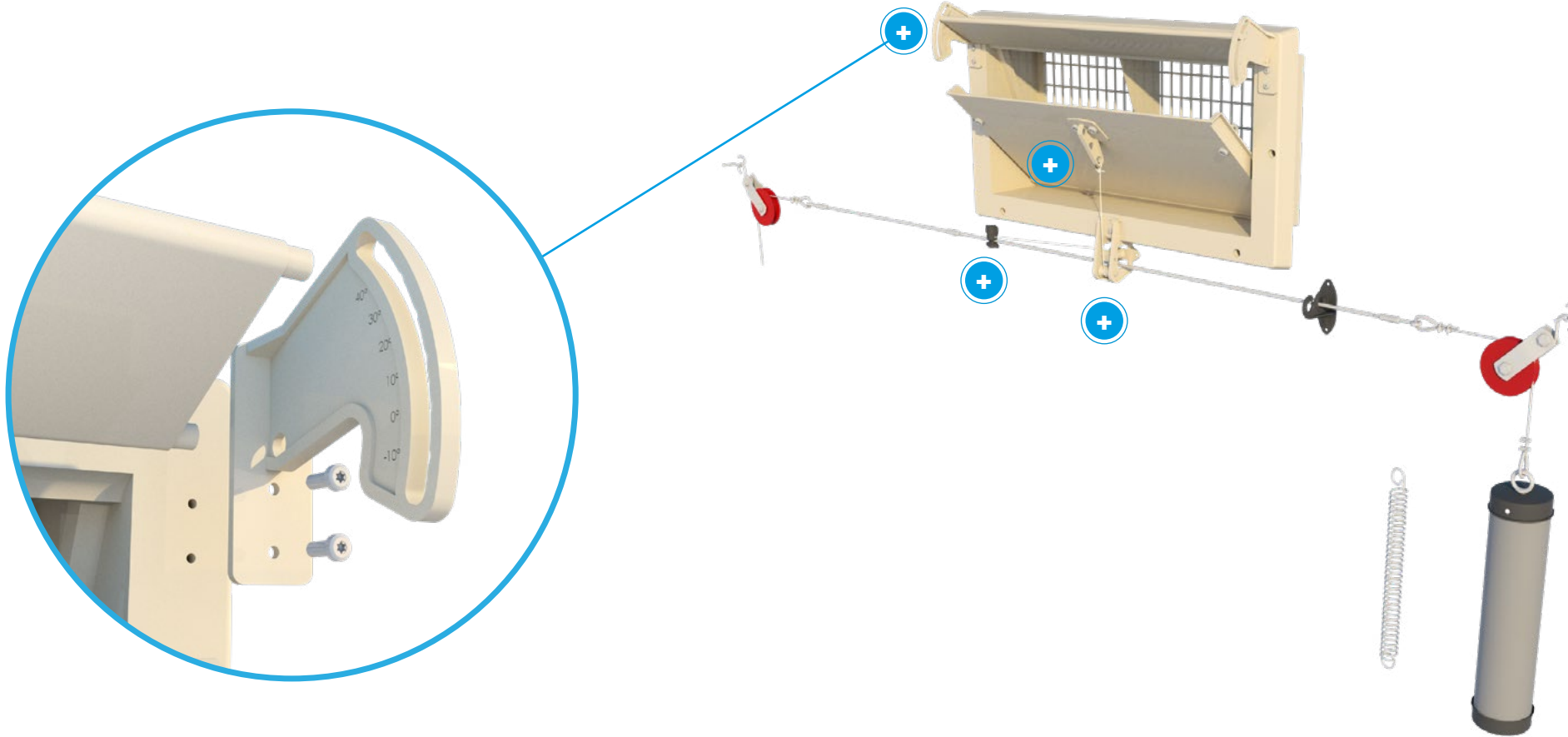

INFO

DATASHEET

ASSEMBLY

MOUNTING

WORKING

MAINTENANCE



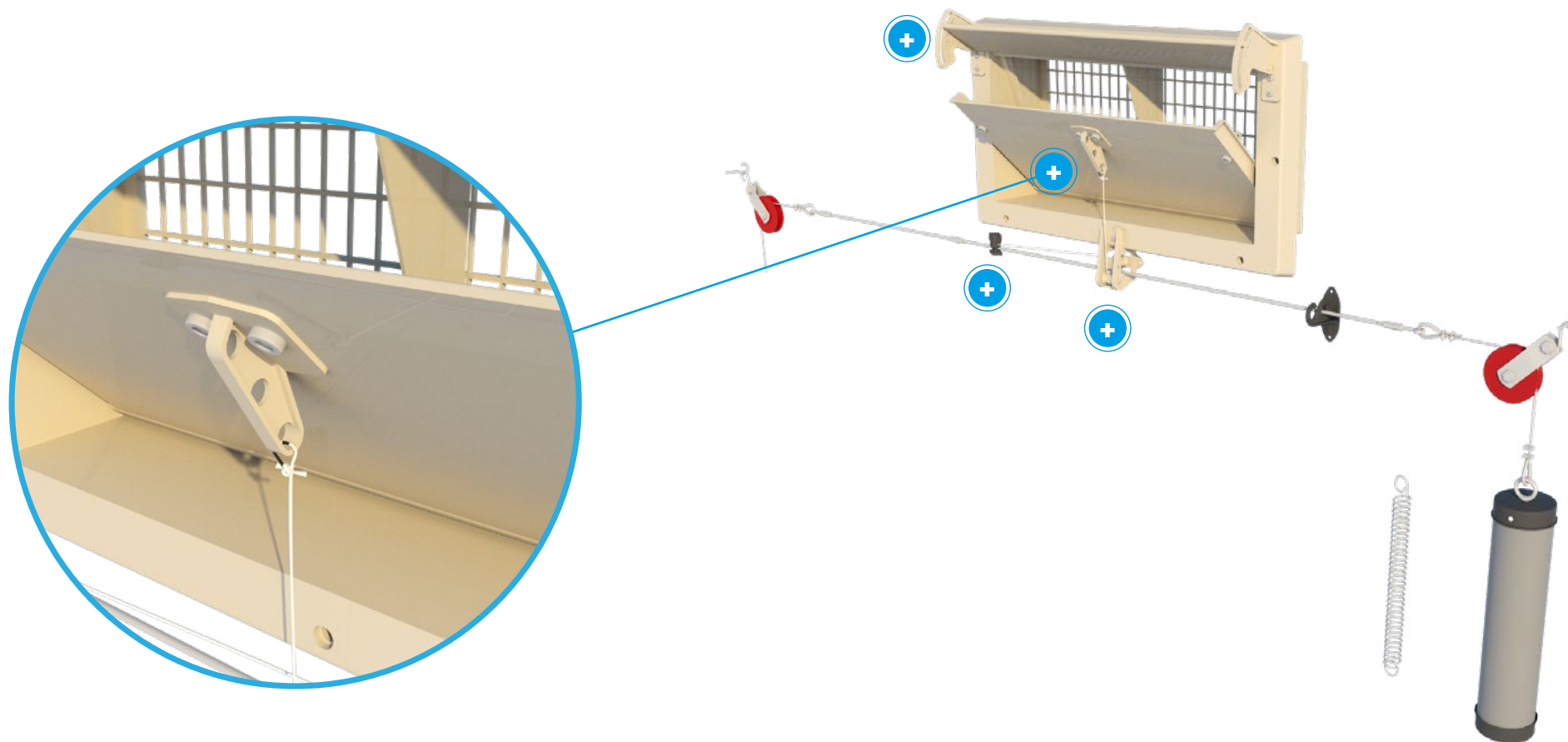



TPI-204C

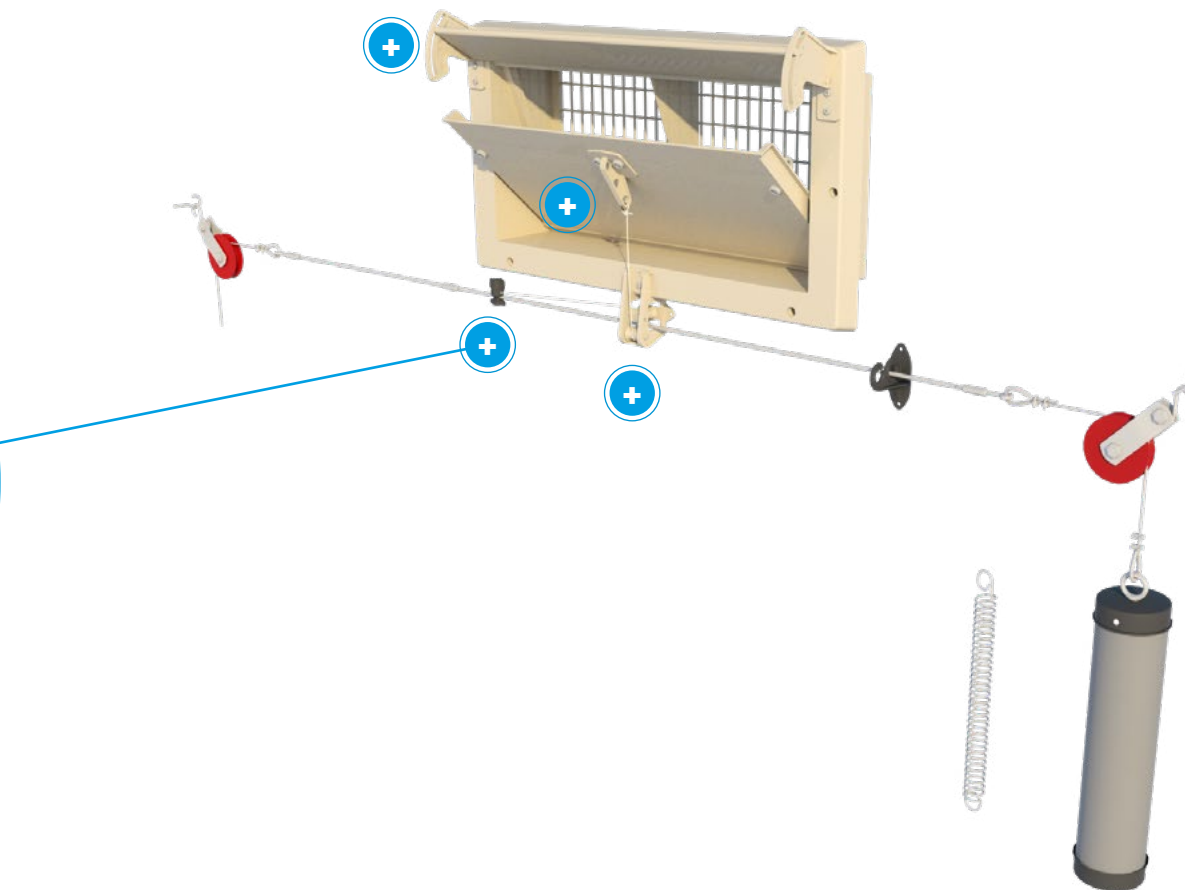

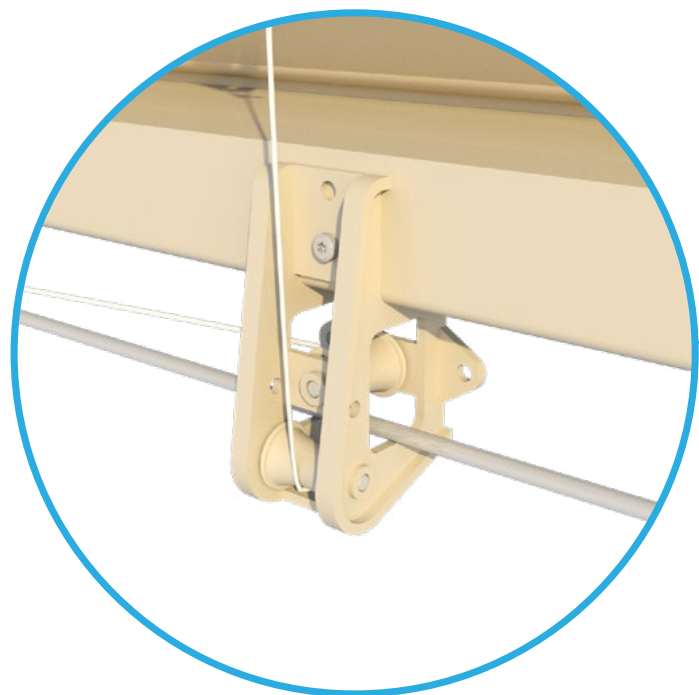

TPI-420

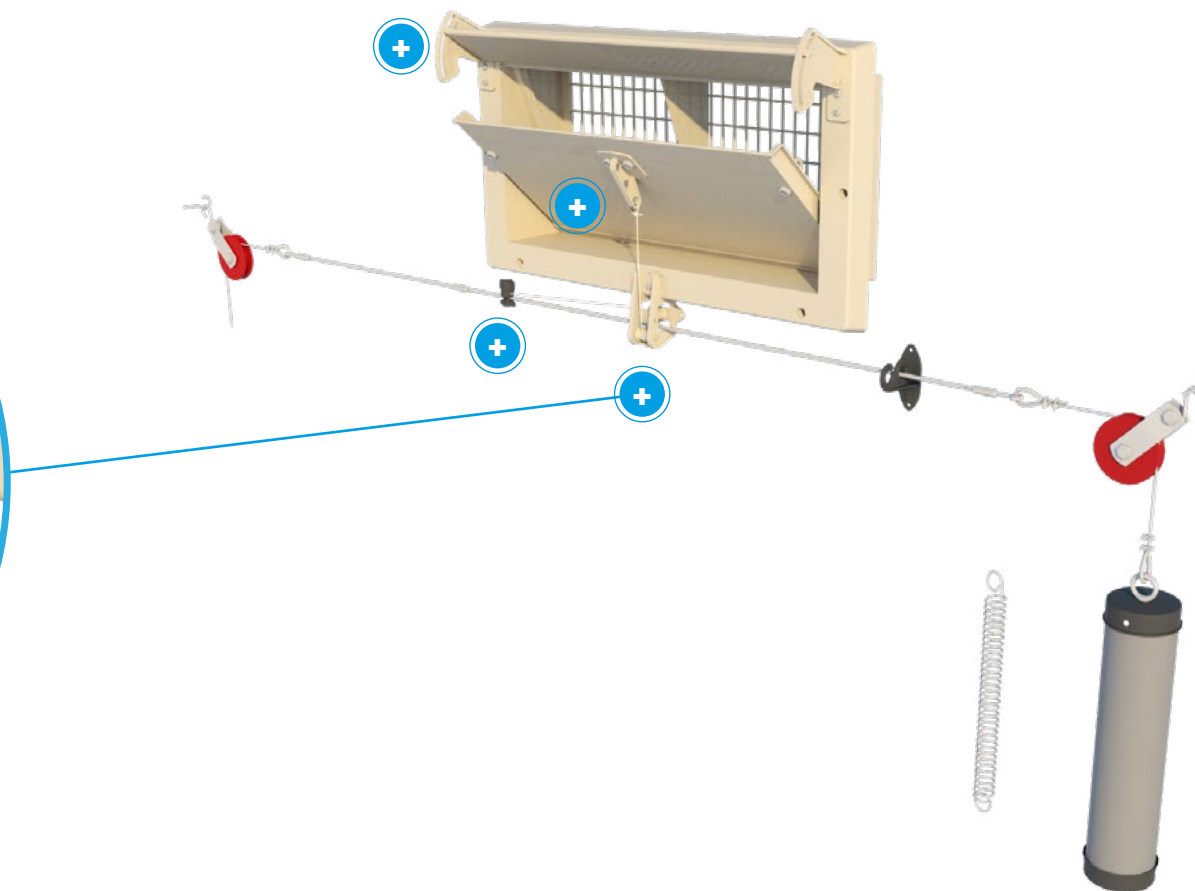

INFO

DATASHEET

ASSEMBLY

MOUNTING

WORKING

MAINTENANCE



All sizes are in cm and inches

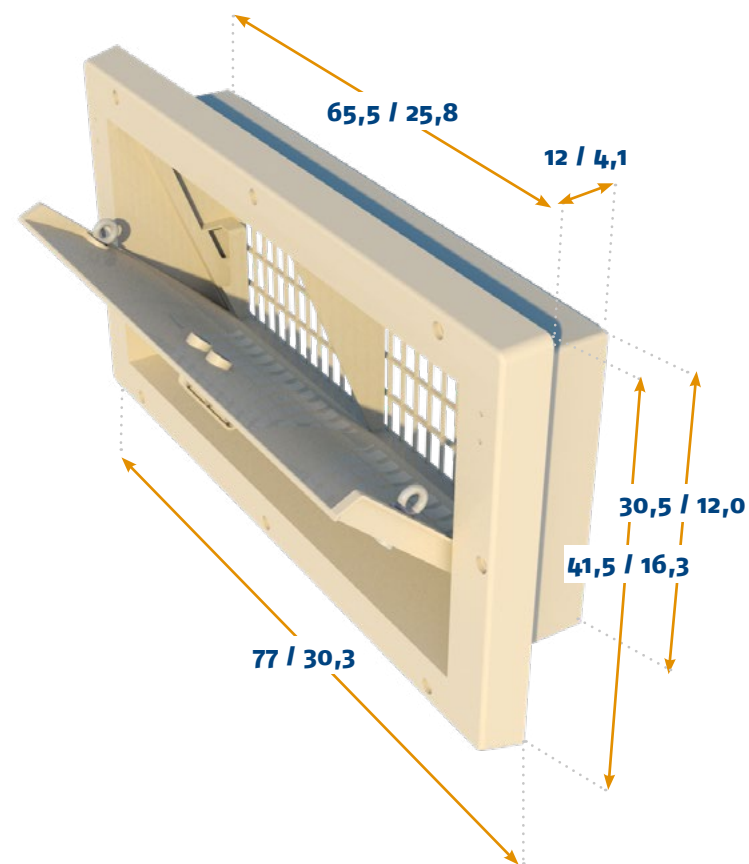
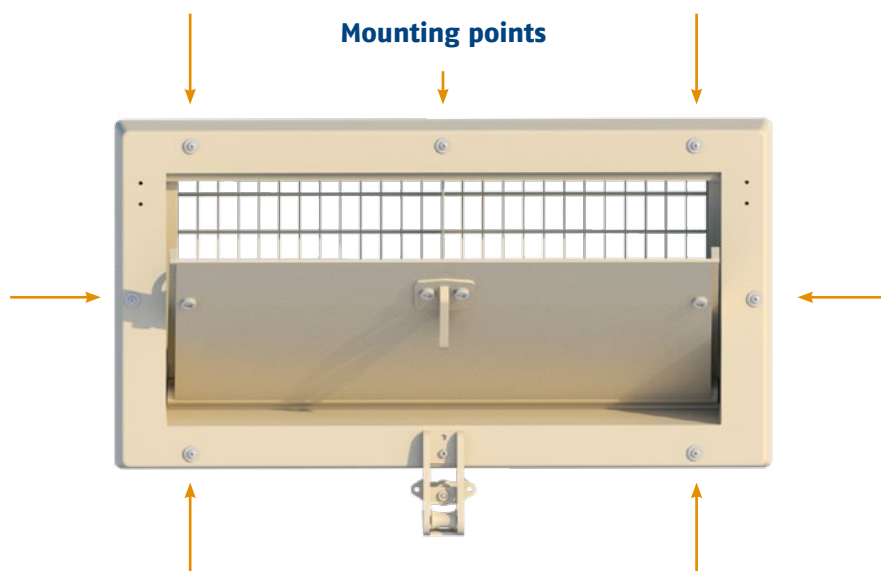

MOUNTING

Mounting type	Wall
Mounting hole size	67,5 cm / 26,6 inch x 32,5 cm / 12,8 inch

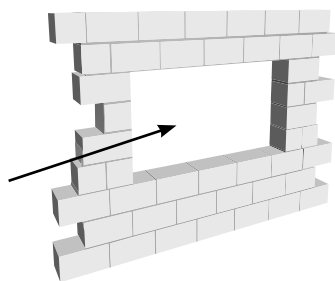

INFO

DATASHEET

ASSEMBLY

MOUNTING

WORKING

MAINTENANCE



AIR FLOW

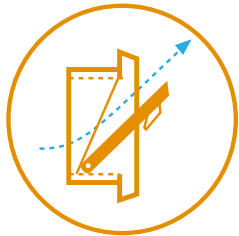

Spring Closed

The 2000-PBR-C inlet is spring closed and therefore the pulley is mounted upside down on the bottom flange. The nylon cord runs from the central arm downwards through the hanging pulley.

Bottom hinged inlet

This bottom hinged inlet is made to guide air over the inner flap upwards into the house. This inlet is perfectly suitable for colder climates where air is not meant to be directed towards the animals, even during maximum ventilation.

Straight inner flap

This inlet is equipped with a straight inner flap. Straight flaps guide air in a straight upwards or horizontal direction, never downwards. This is ideal for houses where air should not be directed directly towards or over the animals during maximum ventilation.

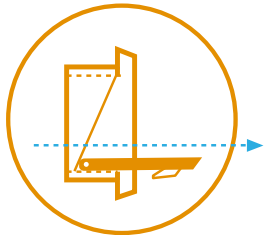

Working with end-weights or springs

We offer two products which can be used to keep tension on the main cable. A PVC cylinder which can be filled with concrete or sand to act as end-weight, or a spring that holds tension on the cable.

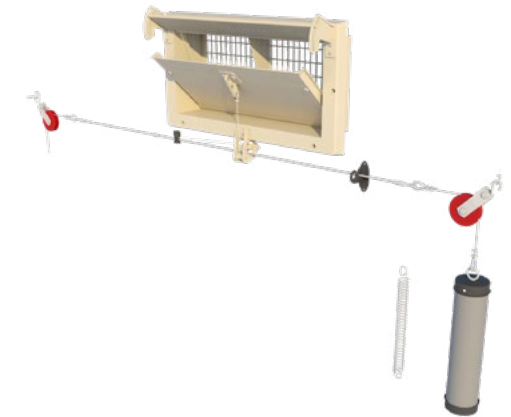

INFO

DATASHEET

ASSEMBLY

MOUNTING

WORKING

MAINTENANCE



2500-PVF(T)

As an exception to our program this inlet is not made out of polyurethane but out of polypropylene. This inlet is especially useful in areas where insulation is less relevant. With a slightly curved inner valve, which is middle hinged, air is also guide downwards to the animals during maximum ventilation.

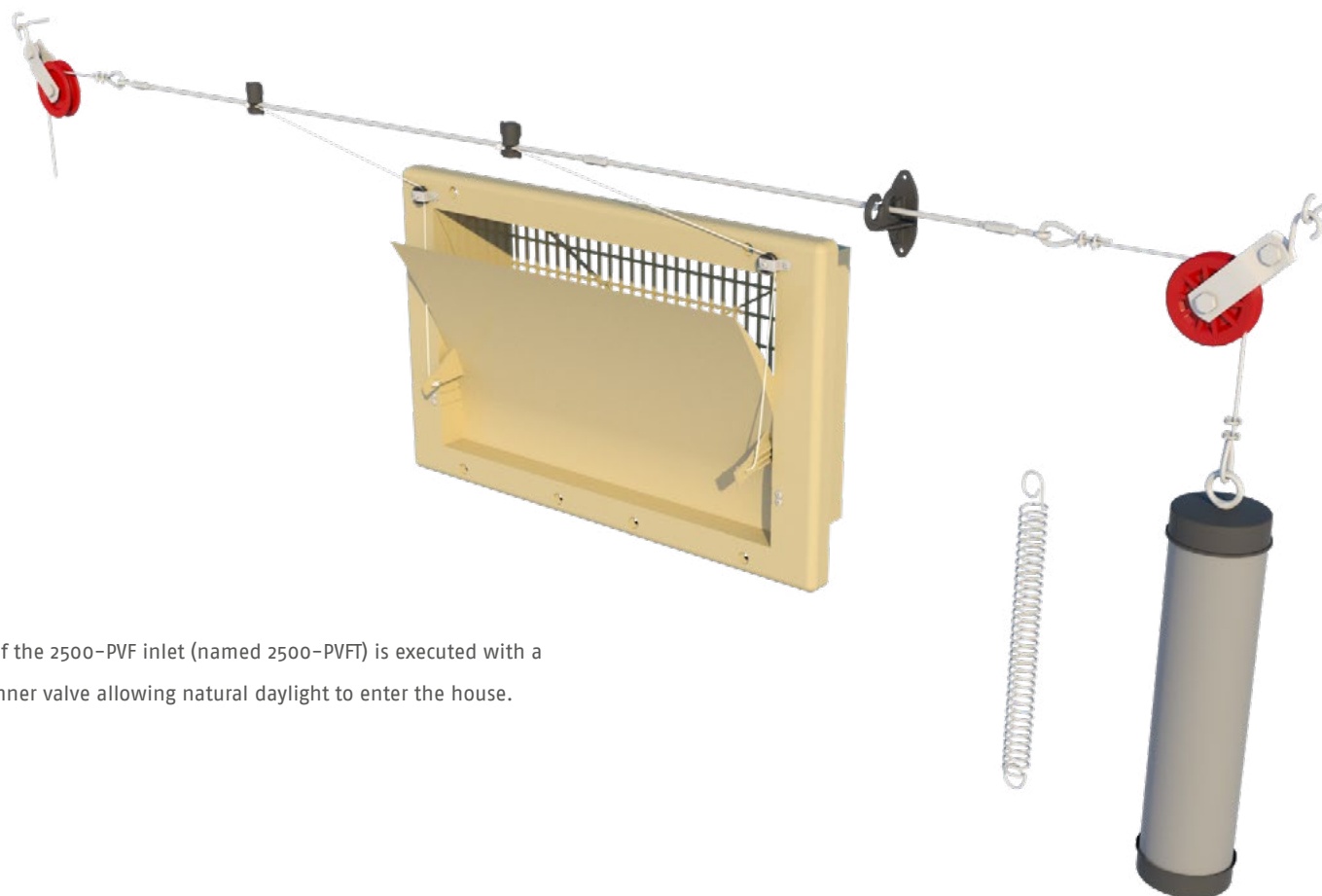

This version of the 2500-PVF inlet (named 2500-PVFT) is executed with a transparent inner valve allowing natural daylight to enter the house.

INFO

DATASHEET

ASSEMBLY

MOUNTING

WORKING

MAINTENANCE





2500-PVF(T) DATASHEET



CAPACITY

Model	m ³ /h @ 10 Pa	m ³ /h @ 20 Pa	m ³ /h @ 40 Pa
2500-PVF	2500	3750	5000
	cfm @ 0.05 inH ₂ O	cfm @ 0.1 inH ₂ O	cfm @ 0.15 inH ₂ O
	1645	2463	2842

INFORMATION

Run	15 cm / 5.9 inch
Force	3,5 kg / 34.3 Newton
Number / pallet (1,20 x 0,80 x 2,40m / 47 x 31,5 x 94,5inch)	36
Weight / per inlet	4,2 kg / 9.3 lbs
Volume / per box	12

OPTIONAL ACCESSORIES

TPI-205 (*2)	Connection set
--------------	----------------

AIR FLOW

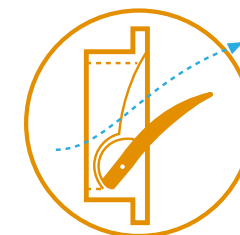
[INFO](#)[DATASHEET](#)[ASSEMBLY](#)[MOUNTING](#)[WORKING](#)[MAINTENANCE](#)

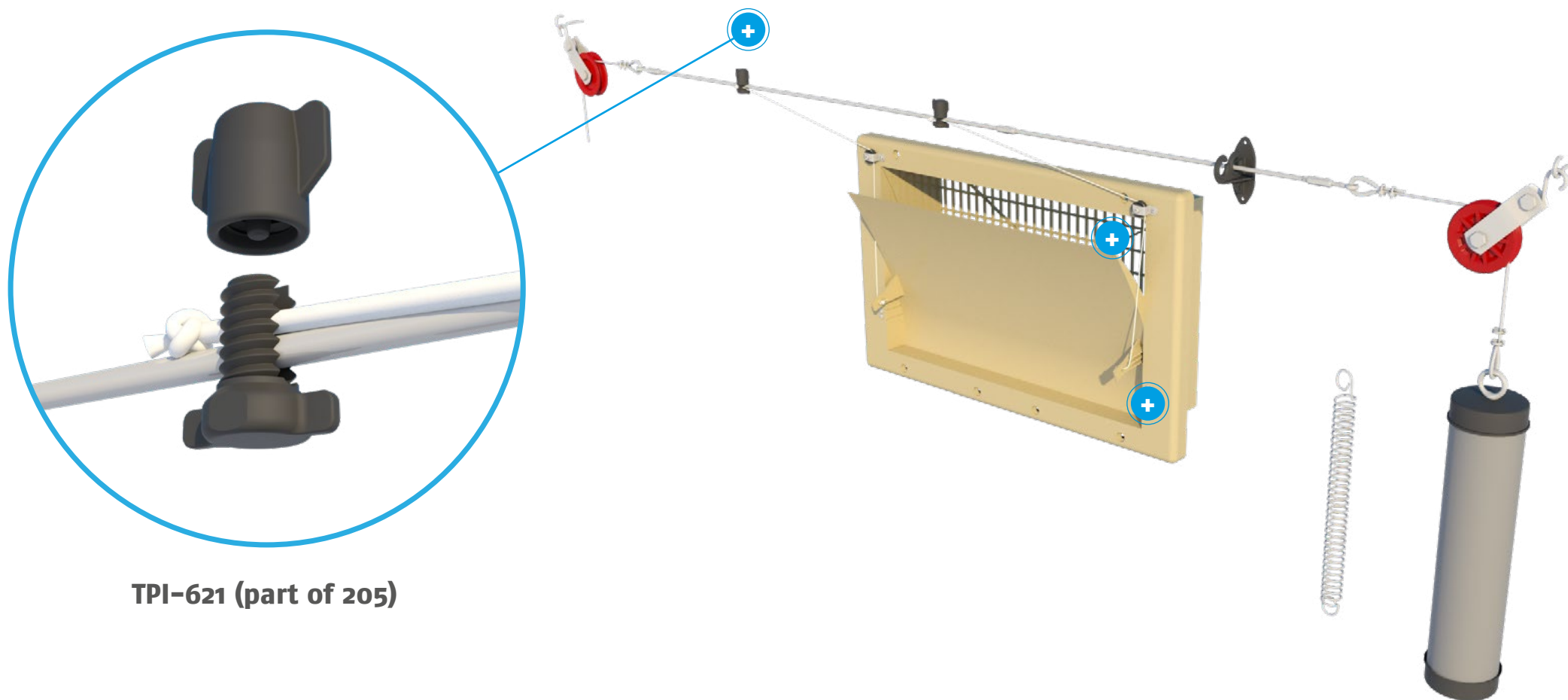

TPI-621 (part of 205)

INFO

DATASHEET

ASSEMBLY

MOUNTING

WORKING

MAINTENANCE



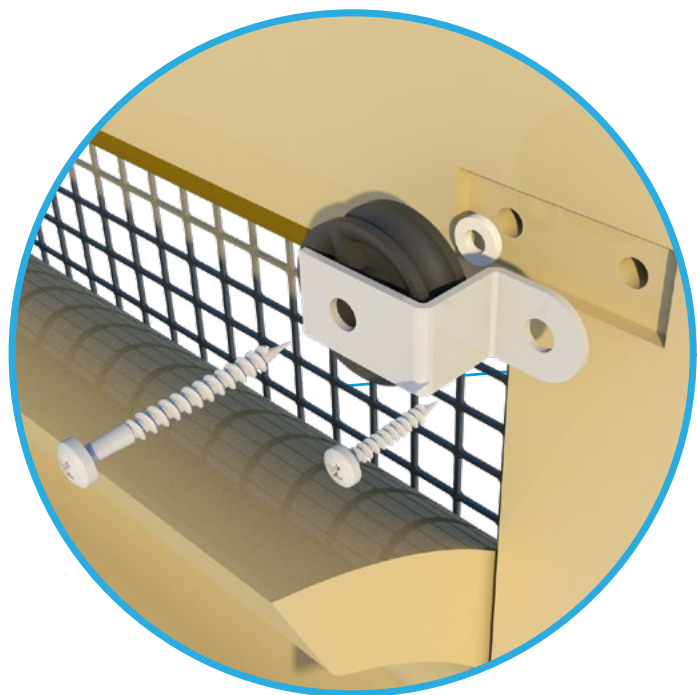

TPI-205

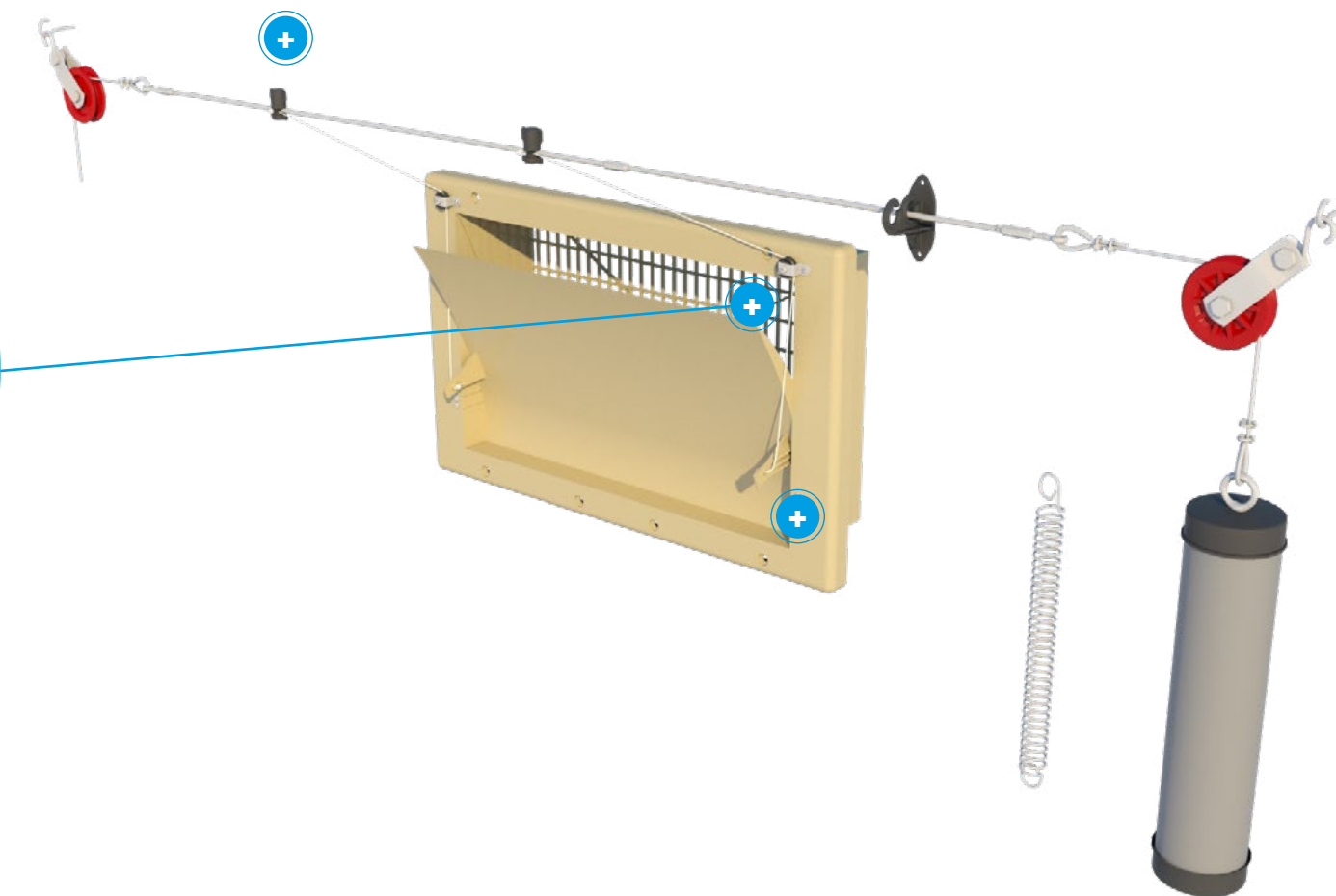

INFO

DATASHEET

ASSEMBLY

MOUNTING

WORKING

MAINTENANCE



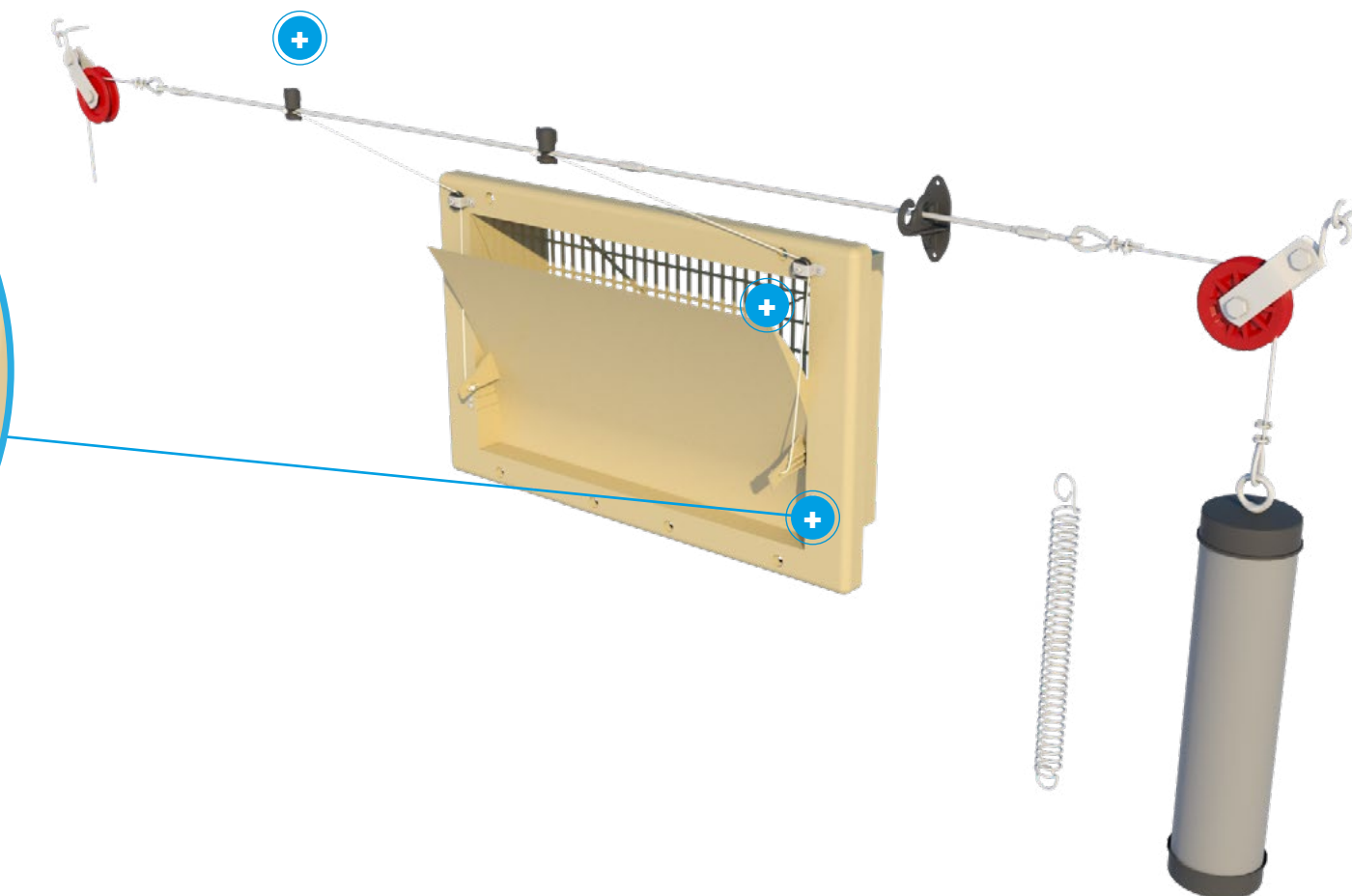
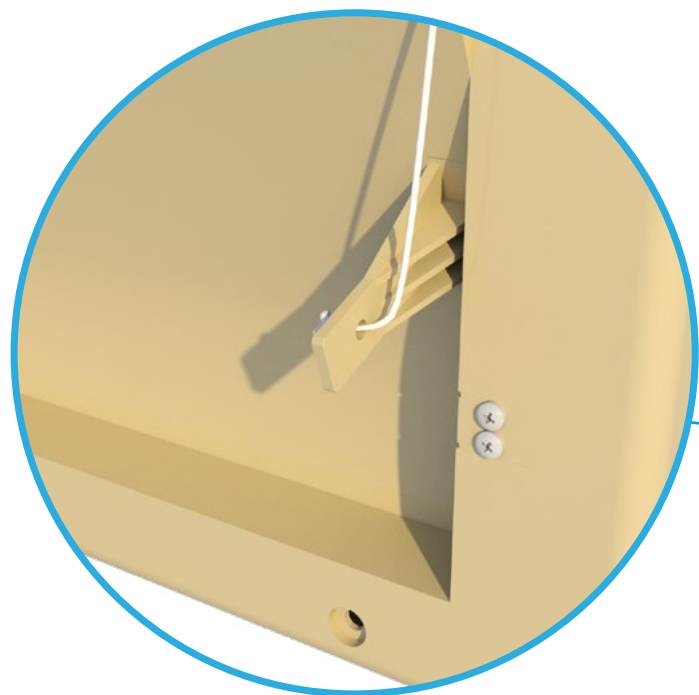

TPI-205 (Including TPI 621)

All sizes are in cm and inches

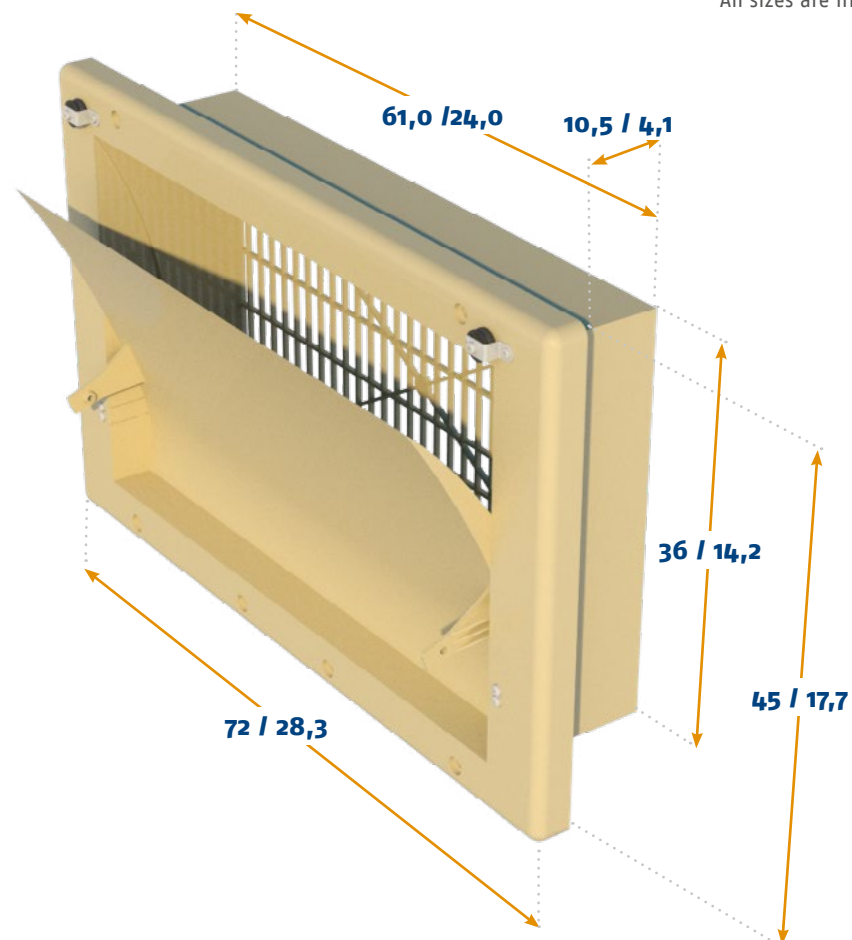
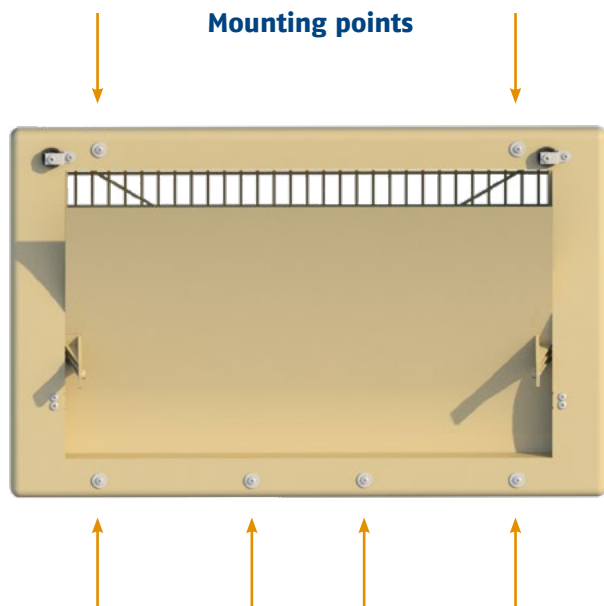

MOUNTING	
Mounting type	Wall
Mounting hole size	63 cm / 24,8 inch x 38 cm / 15,0 inch

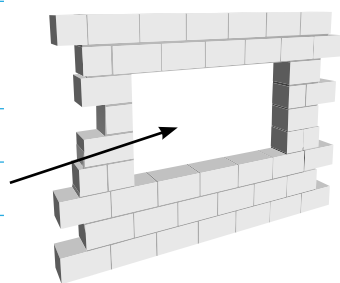

AIR FLOW

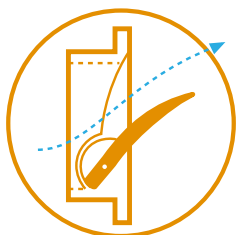

Bottom hinged inlet

This bottom hinged inlet is made to guide air over the inner flap upwards into the house. This inlet is perfectly suitable for colder climates where air is not meant to be directed towards the animals, even during maximum ventilation.

Curved inner flap

This inlet is equipped with a curved inner flap. Curved flaps guide the air upwards during minimum ventilation, but also downwards after a certain point of opening. This is ideal for houses where air should be directed directly towards or over the animals during maximum ventilation.

Working with end-weights or springs

We offer two products which can be used to keep tension on the main cable. A PVC cylinder which can be filled with concrete or sand to act as end-weight, or a spring that holds tension on the cable.

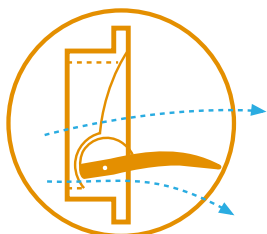

Balanced set-up

When placing the motor winch or actuator we normally suggest to divide the inlets in two groups. It is preferable to place the winch or actuator in the middle to equally divide the forces on the main cable.

(see ventilation concepts page for an example)

Use of closing catches

The closing catch on the inlet can be used to permanently close inlets for example during pre-heating. The closing catches can also be used to close certain inlets while continuing to use others. In that case the used inlets can be opened a bit further. In colder climates this can help to offer better resistance to freezing effects.

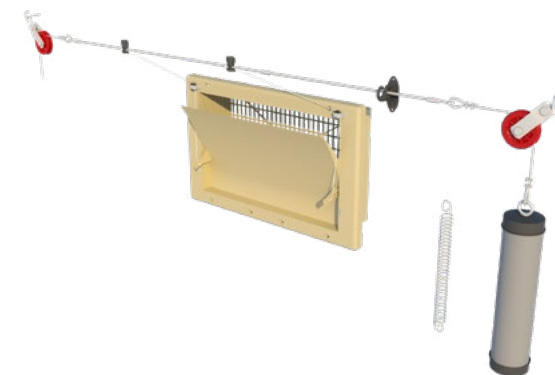
[INFO](#)
[DATASHEET](#)
[ASSEMBLY](#)
[MOUNTING](#)
[WORKING](#)
[MAINTENANCE](#)



2800-VFRM

This motorized inlet is unique in its control. Equipped with a motor this inlet does not have to be connected to a main cable but instead operates on its own. With a straight inner valve air is guided upwards as much as possible during minimum ventilation. This inlet, like the majority of our program, is made out of our unique polyurethane formula thus offering high insulation values.

The type of cable depends on the number of 2800-VFRM and the length of the cable in meters: The air inlets need to be connected using 2 x 2 leads:

- 2 leads to feed the 24 Volt DC motor
- 2 leads to feed the 0-10 volt control signal

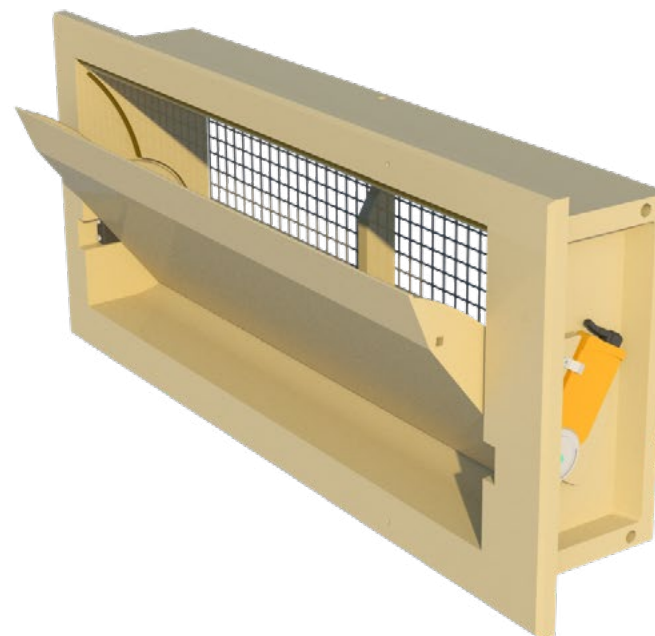
We advise that a four lead cable is used. The thickness of the cable is determined by the 24 volt feed.

[INFO](#)[DATASHEET](#)[ASSEMBLY](#)[MOUNTING](#)[WORKING](#)[MAINTENANCE](#)

CAPACITY

Model	m ³ /h @ 10 Pa	m ³ /h @ 20 Pa	m ³ /h @ 40 Pa
2800-VFRM	2900	4100	5800
	cfm @ 0.05 inH ₂ O	cfm @ 0.1 inH ₂ O	cfm @ 0.15 inH ₂ O
	1908	2693	3297

INFORMATION

Run	N/A
Force	N/A
Number / pallet (1,20 x 0,80 x 2,40m / 47 x 31,5 x 94,5inch)	20
Weight / per inlet	5,6 kg / 12.3 lbs
Volume / per box	10

OPTIONAL ACCESSORIES

TPI-110 Wire mesh synthetic

INFORMATION

Copper resistance	0.0175 Ohm
Voltage	24 Vdc
Maximum tolerance	10%
Maximum voltage drop	2.4 Vdc
Electric current	0.21 A

AIR FLOW

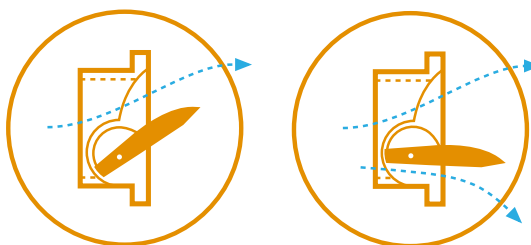

CABLE DIMENSIONS

Motors	4 x 0.5mm ²	4 x 1.0 mm ²	4 x 1.5 mm ²	4 x 2.5 mm ²
1	163 m	327 m	490 m	816 m
2	82 m	163 m	245 m	408 m
3	54 m	109 m	163 m	272 m
4	41 m	82 m	122 m	204 m
5	33 m	65 m	98 m	163 m
6	27 m	54 m	82 m	136 m
7	23 m	47 m	70 m	117 m
8	20 m	41 m	61 m	102 m
9	18 m	36 m	54 m	91 m
10	16 m	33 m	49 m	82 m

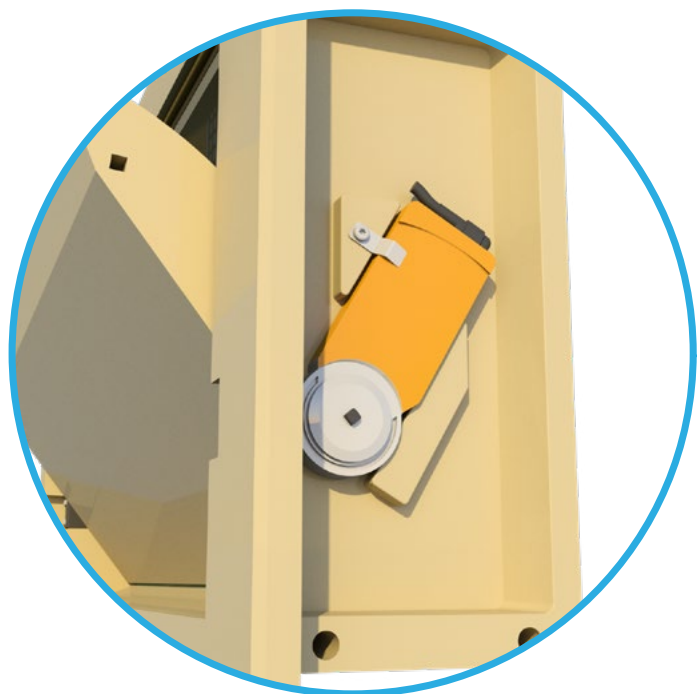

CM24

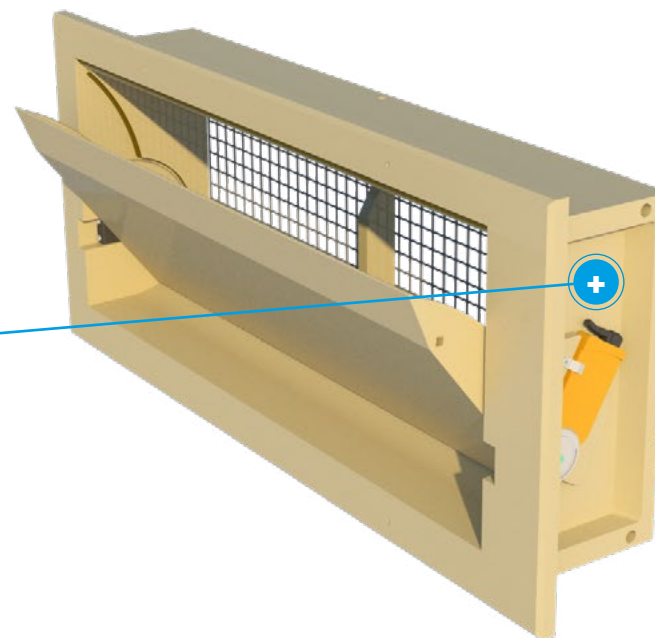

INFO

DATASHEET

ASSEMBLY

MOUNTING

WORKING

MAINTENANCE



All sizes are in cm and inches

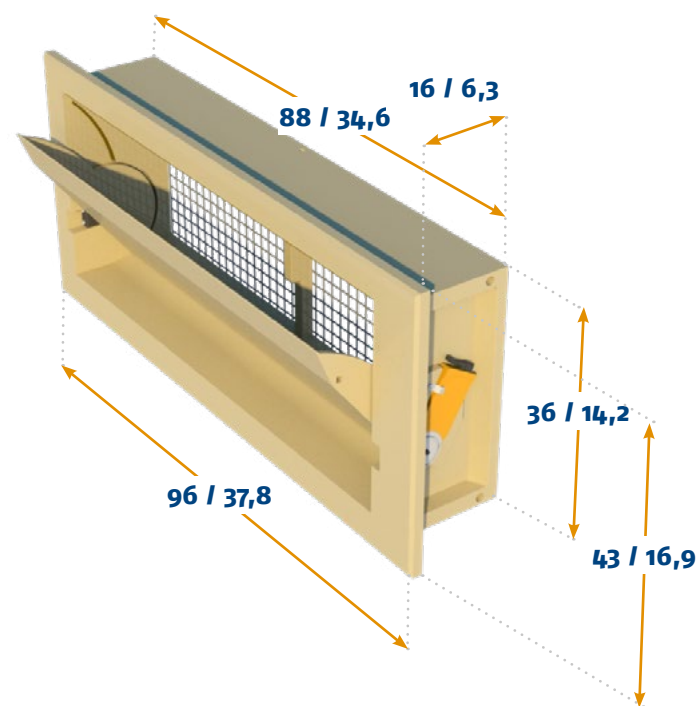
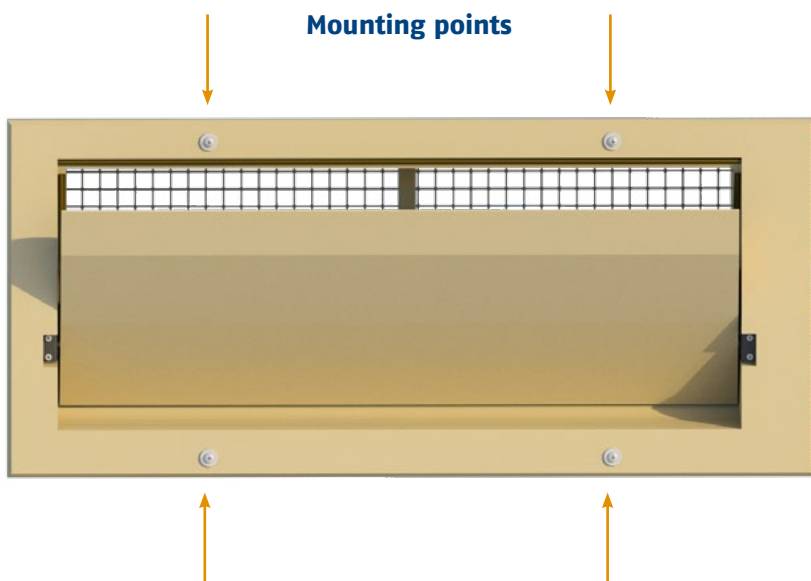

MOUNTING	
Mounting type	Wall
Mounting hole size	90 cm / 35,4 inch x 38 cm / 15,0 inch

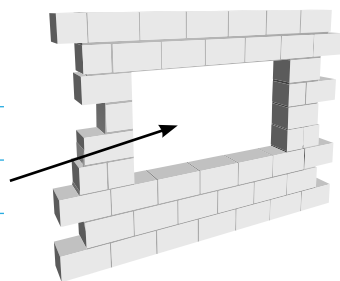

AIR FLOW

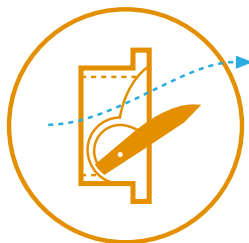

Motorized opening and closing

This inlet is not operated by use of a traditional main cable and motor winch or actuator. The 2800-VFRM opens and closes with an electric motor that is built onto the house of the inlet. In houses where obstructions on the wall make installation of a main cable difficult, this inlet is especially useful.

Bottom hinged inlet

This bottom hinged inlet is made to guide air over the inner flap upwards into the house. This inlet is perfectly suitable for colder climates where air is not meant to be directed towards the animals, even during maximum ventilation.

Straight inner flap

This inlet is equipped with a straight inner flap. Straight flaps guide air in a straight upwards or horizontal direction, never downwards. This is ideal for houses where air should not be directed directly towards or over the animals during maximum ventilation.

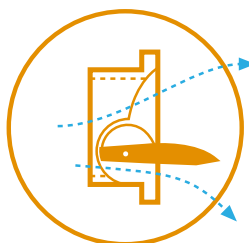
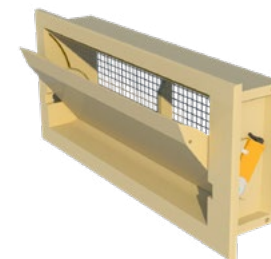

INFO

DATASHEET

ASSEMBLY

MOUNTING

WORKING

MAINTENANCE



3000-VFG-C

This inlet is suitable mostly for poultry. With a middle hinged inner valve the air will be divided and also flows underneath the valve when it is opened over 35%. The curved inner valve helps to guide air downwards to the animals during maximum ventilation. The valve and house of this inlet are equipped with seals all around to prevent air leakage. Curved inner corners in the house make for a better air flow. The combination of materials and air seals help to make this inlet perfectly suitable for use in extremely low temperatures.

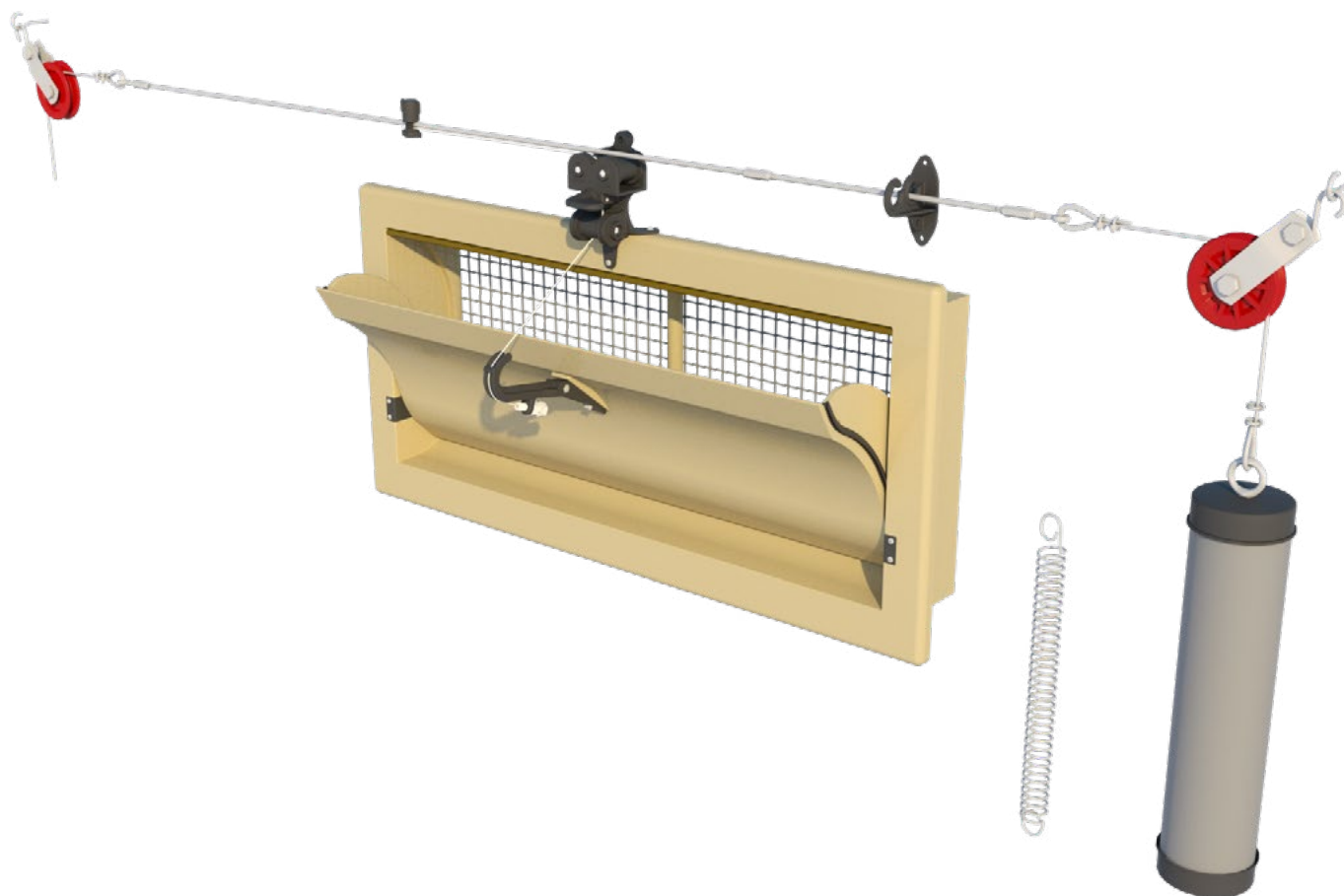

INFO

DATASHEET

ASSEMBLY

MOUNTING

WORKING

MAINTENANCE





3000-VFG-C DATASHEET



CAPACITY

Model	m ³ /h @ 10 Pa	m ³ /h @ 20 Pa	m ³ /h @ 40 Pa
3000-VFG-C	2900	4100	5800
	cfm @ 0.05 inH ₂ O	cfm @ 0.1 inH ₂ O	cfm @ 0.15 inH ₂ O
	1908	2693	3297

INFORMATION

Run	43 cm / 16.9 inch
Force	2 kg / 19.6 Newton
Number / pallet (1,30 x 1,00 x 2,50m / 51 x 39 x 98inch)	42
Weight / per inlet	4,4 kg / 9.7 lbs
Volume / per box	21
Arm position	3

OPTIONAL ACCESSORIES

TPI-118	Wire mesh synthetic
TPI-204c	Connection set
TPI-423	Pulley Unit + Closing Catch
TPI-704	Counter flange for inlets in 3000-series

AIR FLOW

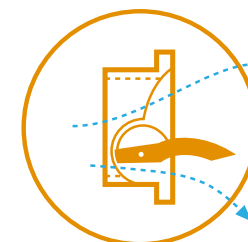
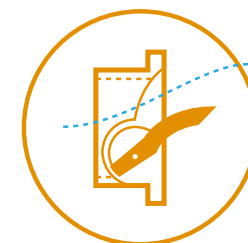

INFO

DATASHEET

ASSEMBLY

MOUNTING

WORKING

MAINTENANCE





TPI-204C

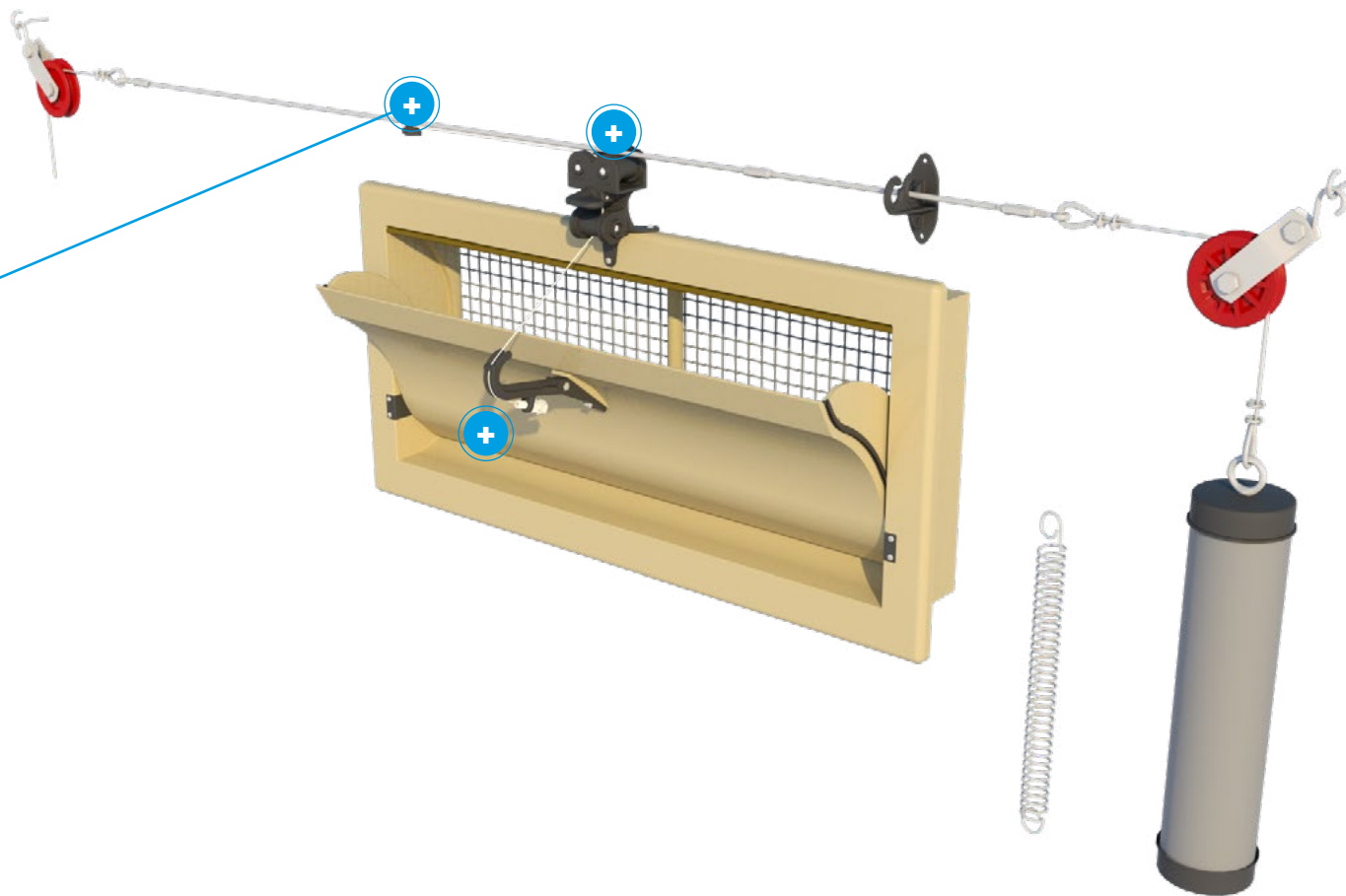

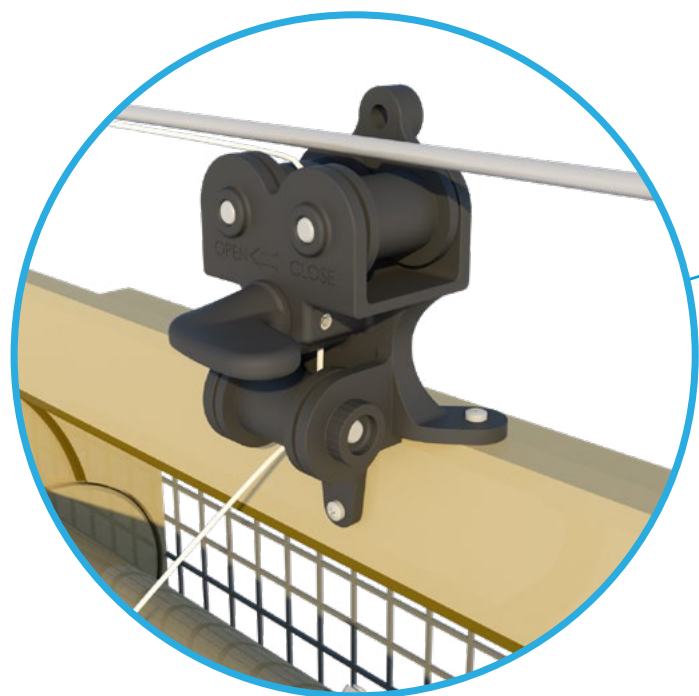

TPI-423

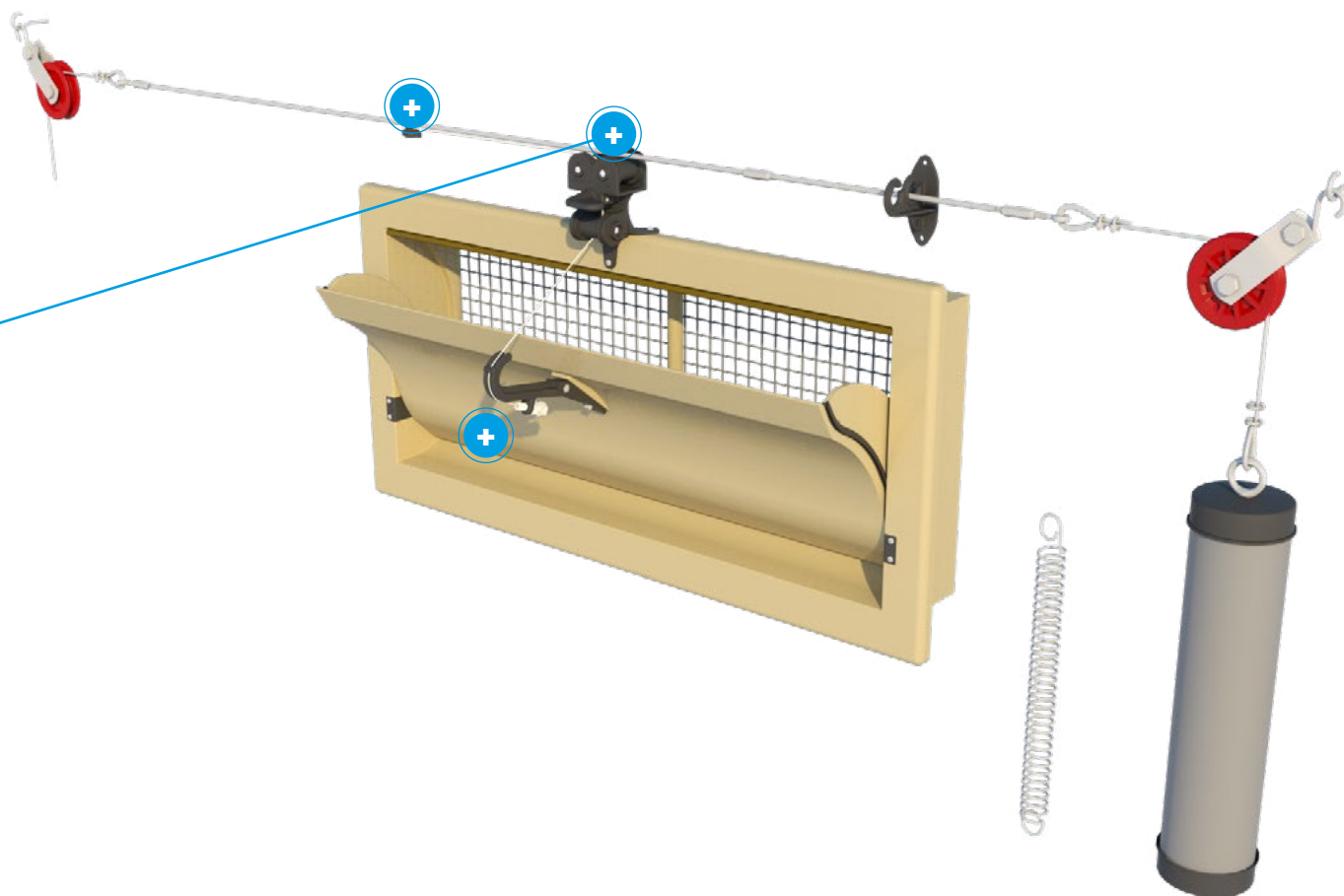

INFO

DATASHEET

ASSEMBLY

MOUNTING

WORKING

MAINTENANCE



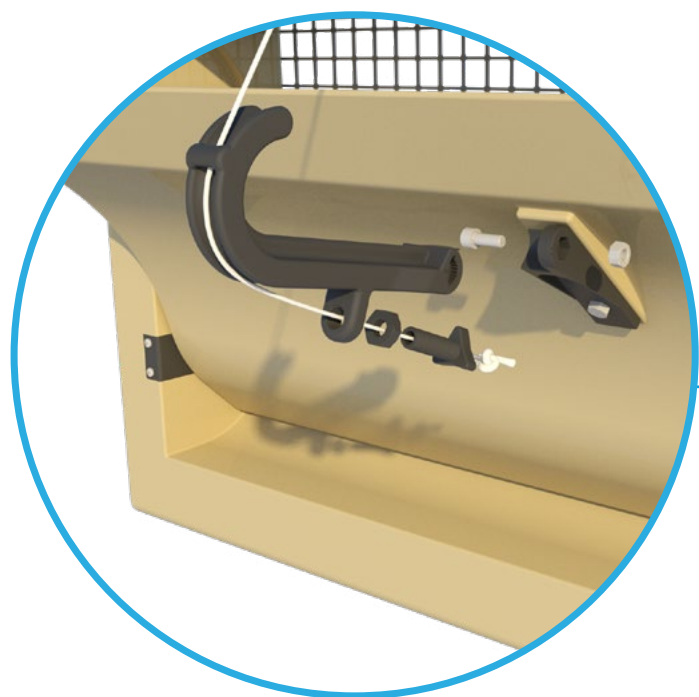

Arm angle position : 3

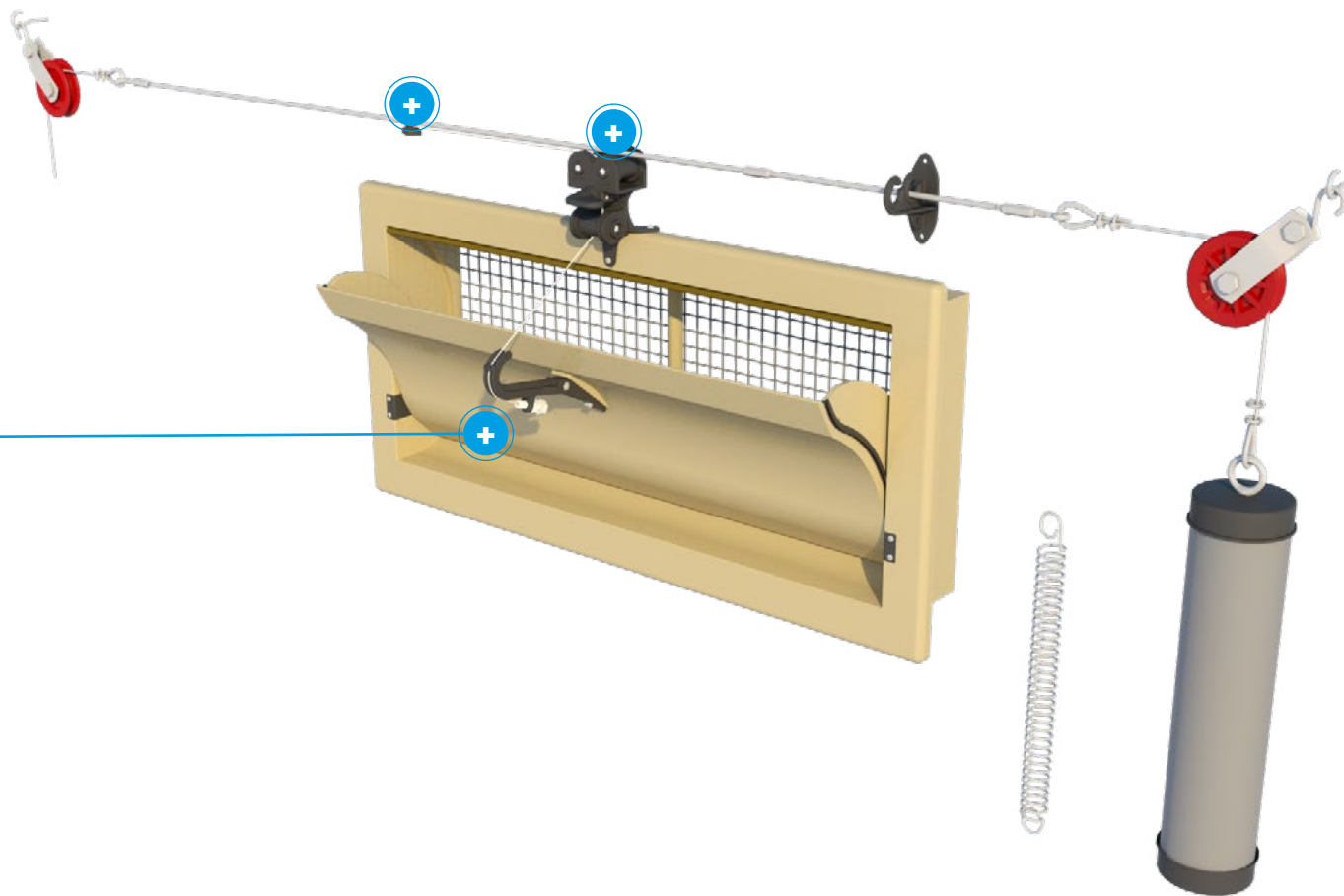

All sizes are in cm and inches

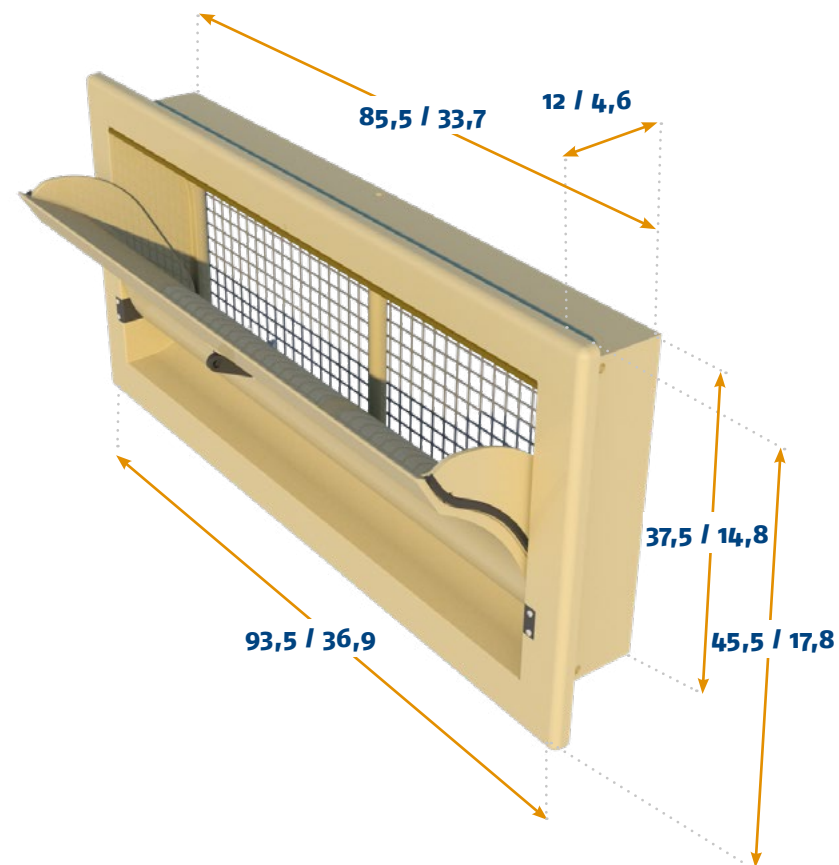
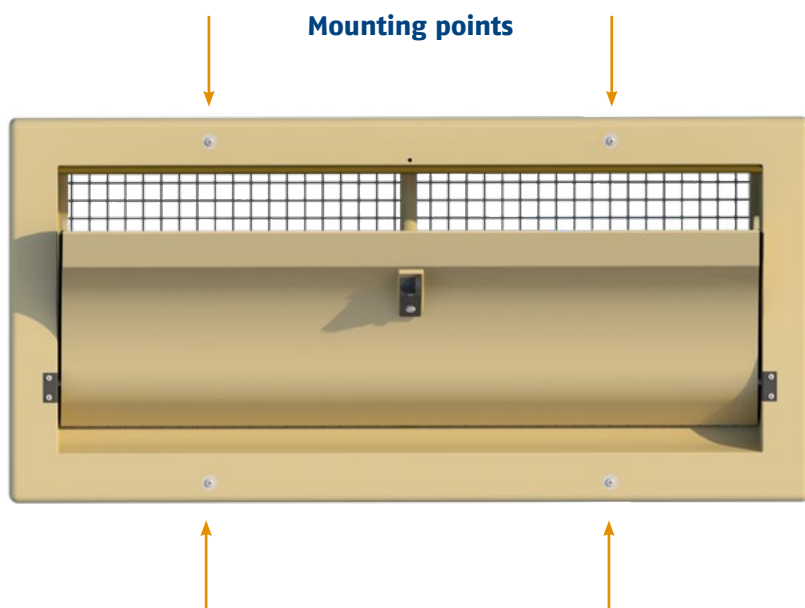

MOUNTING

Mounting type	Wall
Mounting hole size	87,5 cm / 34,5 inch x 39,5 cm / 15,5 inch

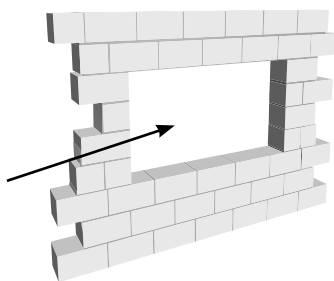

INFO

DATASHEET

ASSEMBLY

MOUNTING

WORKING

MAINTENANCE



AIR FLOW

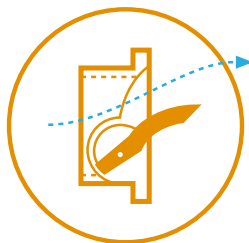

Middle hinged inlet

This middle hinged inlet is made to allow air to also flow underneath the inner flap after opening further then 35%. This helps to guide air downwards to the animals and provide a cooling effect during maximum ventilation.

Curved inner flap

This inlet is equipped with a curved inner flap. Curved flaps guide the air upwards during minimum ventilation, but also downwards after a certain point of opening. This is ideal for houses where air should be directed directly towards or over the animals during maximum ventilation.

Making adjustments

By using the nylon bolt and nut small adjustments can be made to make sure all inlets are closing and opening correctly. The nylon cable clamp and cord can also be used to make small adjustments.

Working with end-weights or springs

We offer two products which can be used to keep tension on the main cable. A PVC cylinder which can be filled with concrete or sand to act as end-weight, or a spring that holds tension on the cable.

Balanced set-up

When placing the motor winch or actuator we normally suggest to divide the inlets in two groups. It is preferable to place the winch or actuator in the middle to equally divide the forces on the main cable.

(see ventilation concepts page for an example)

Use of closing catches

The closing catch on the inlet can be used to permanently close inlets for example during pre-heating. The closing catches can also be used to close certain inlets while continuing to use others. In that case the used inlets can be opened a bit further. In colder climates this can help to offer better resistance to freezing effects.

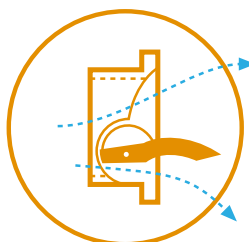

INFO

DATASHEET

ASSEMBLY

MOUNTING

WORKING

MAINTENANCE

☰

3000-VFBR-C

Equipped with a bottom hinged and straight inner valve we make sure the air is not guided downwards to the animals during maximum ventilation. The inner valve and house of this inlet are equipped with seals all around to prevent air leakage. Curved inner corners in the house make for a better air flow. The combination of materials and air seals help to make this inlet perfectly suitable for use in extremely low temperatures.

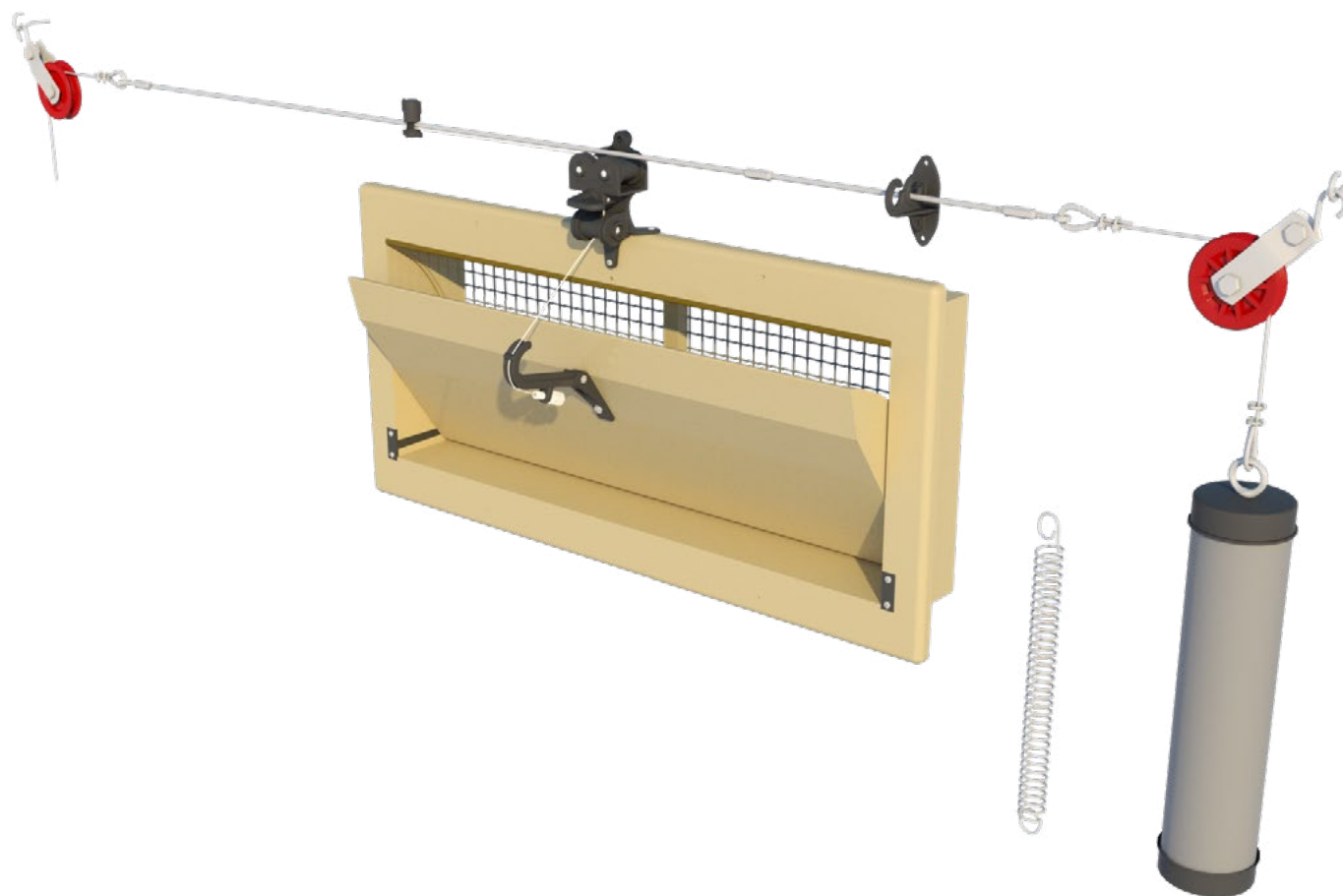

INFO

DATASHEET

ASSEMBLY

MOUNTING

WORKING

MAINTENANCE



CAPACITY

Model	m ³ /h @ 10 Pa	m ³ /h @ 20 Pa	m ³ /h @ 40 Pa
3000-VFBR-C	2900	4100	5800
	cfm @ 0.05 inH ₂ O	cfm @ 0.1 inH ₂ O	cfm @ 0.15 inH ₂ O
	1908	2693	3297

INFORMATION

Run	41 cm / 16.1 inch
Force	2 kg / 19.6 Newton
Number / pallet (1,30 x 1,00 x 2,50m / 51 x 39 x 98inch)	42
Weight / per inlet	4,1 kg / 9 lbs
Volume / per box	21
Arm position	3

OPTIONAL ACCESSORIES

TPI-103	Wire mesh synthetic
TPI-204c	Connection set
TPI-423	Pulley Unit + Closing Catch
TPI-704	Counter flange for inlets in 3000-series

AIR FLOW

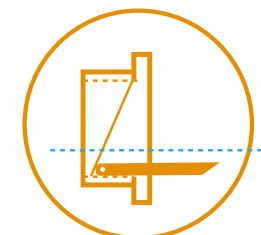
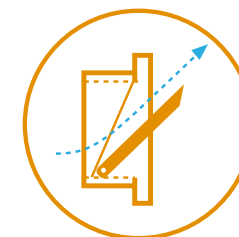
[INFO](#)
[DATASHEET](#)
[ASSEMBLY](#)
[MOUNTING](#)
[WORKING](#)
[MAINTENANCE](#)



TPI-204C

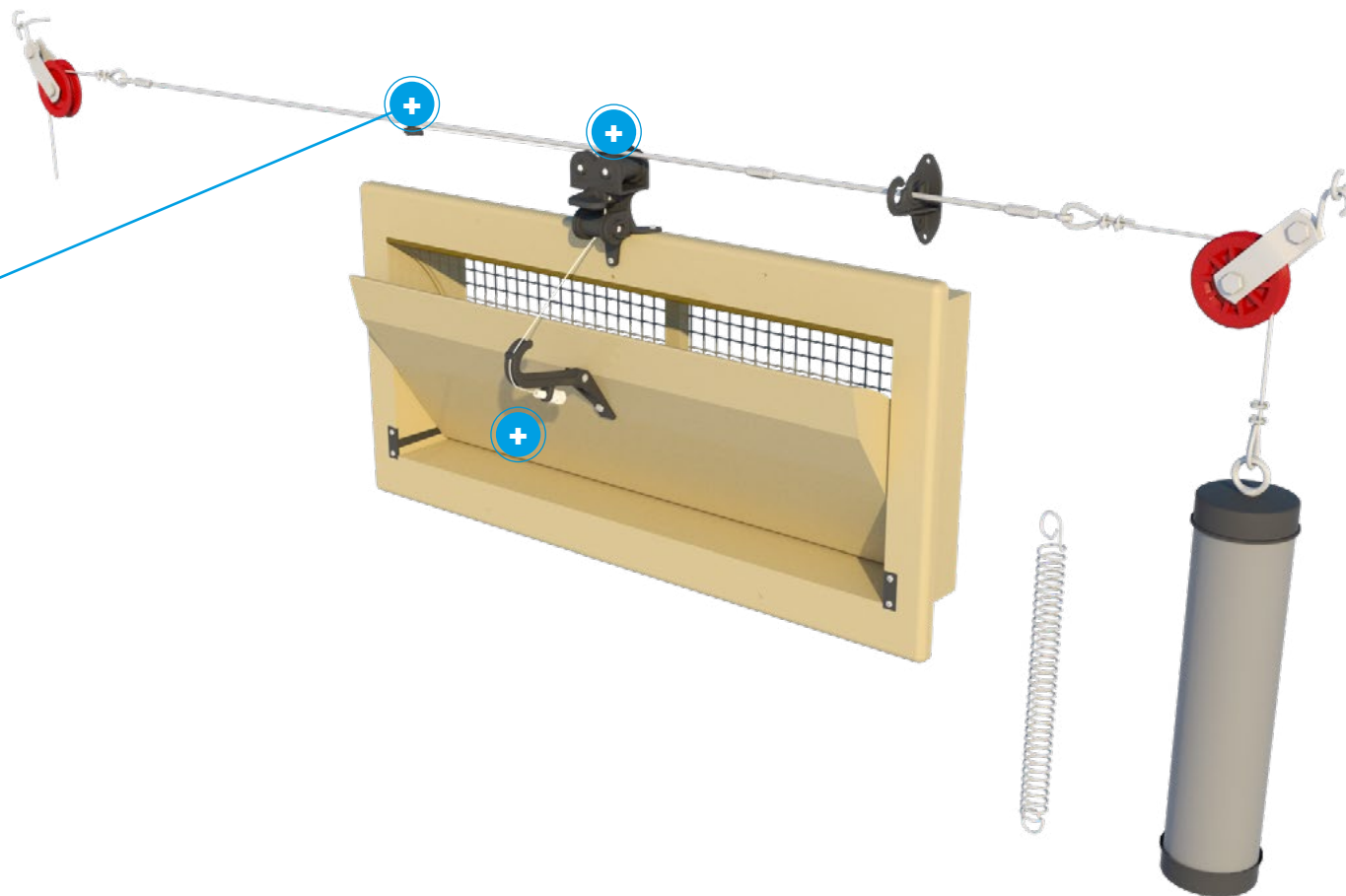

INFO

DATASHEET

ASSEMBLY

MOUNTING

WORKING

MAINTENANCE



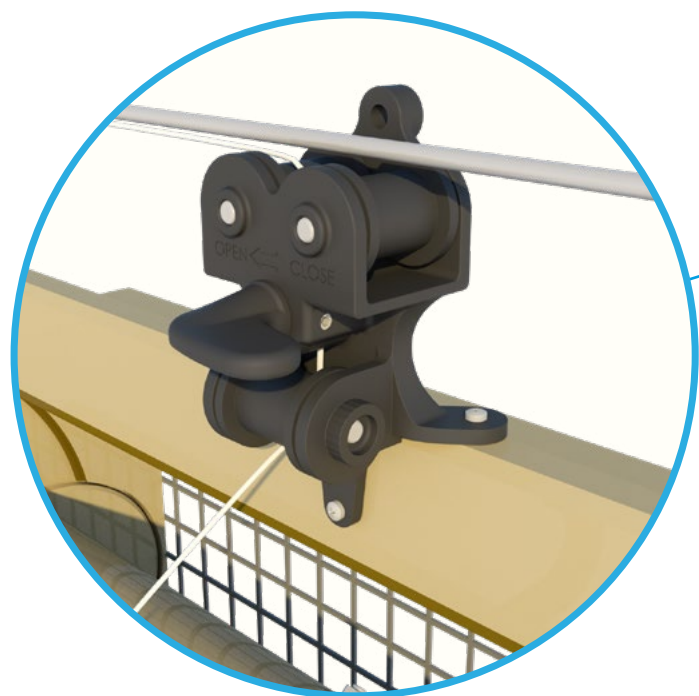

TPI-423

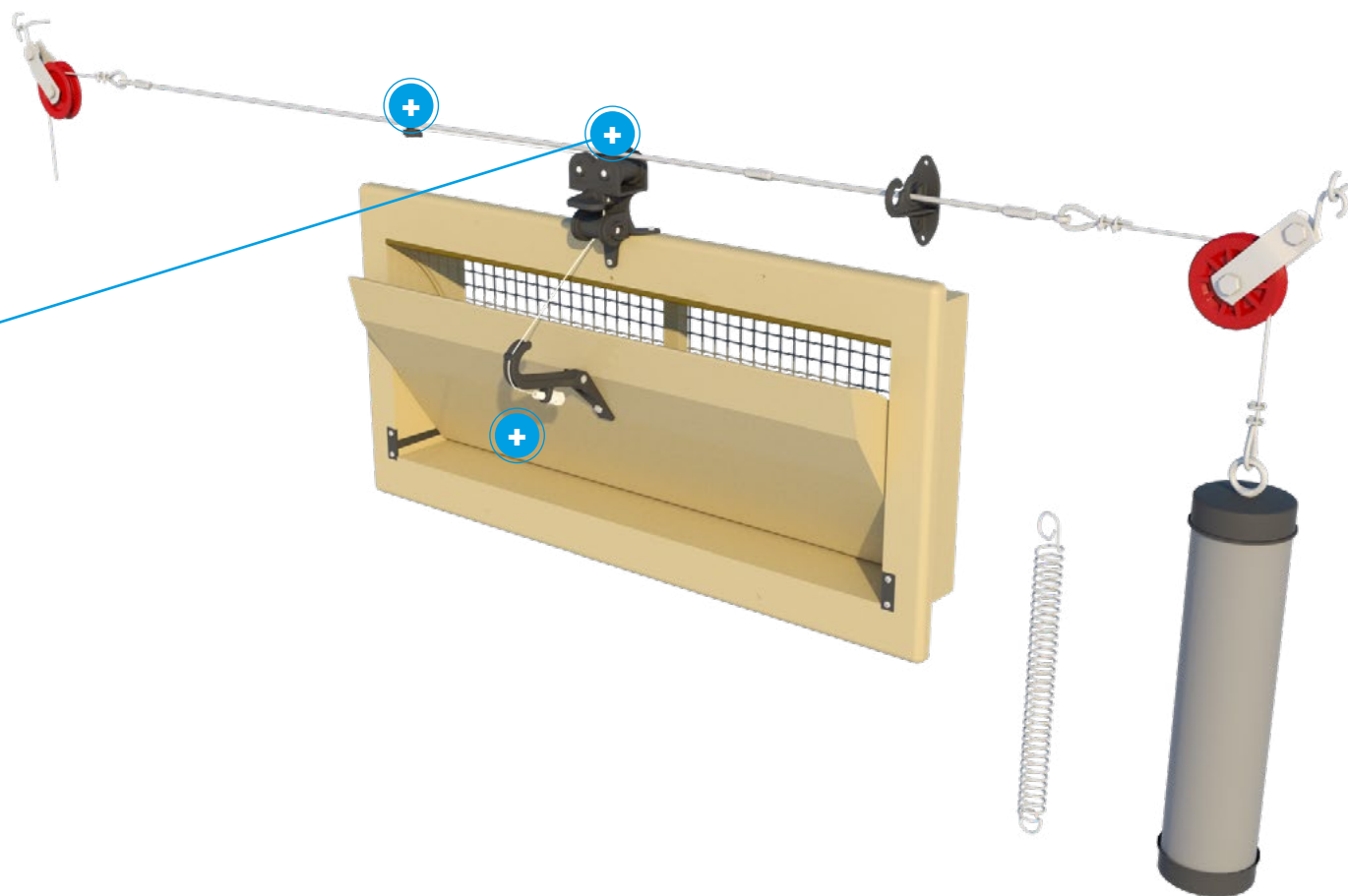

INFO

DATASHEET

ASSEMBLY

MOUNTING

WORKING

MAINTENANCE



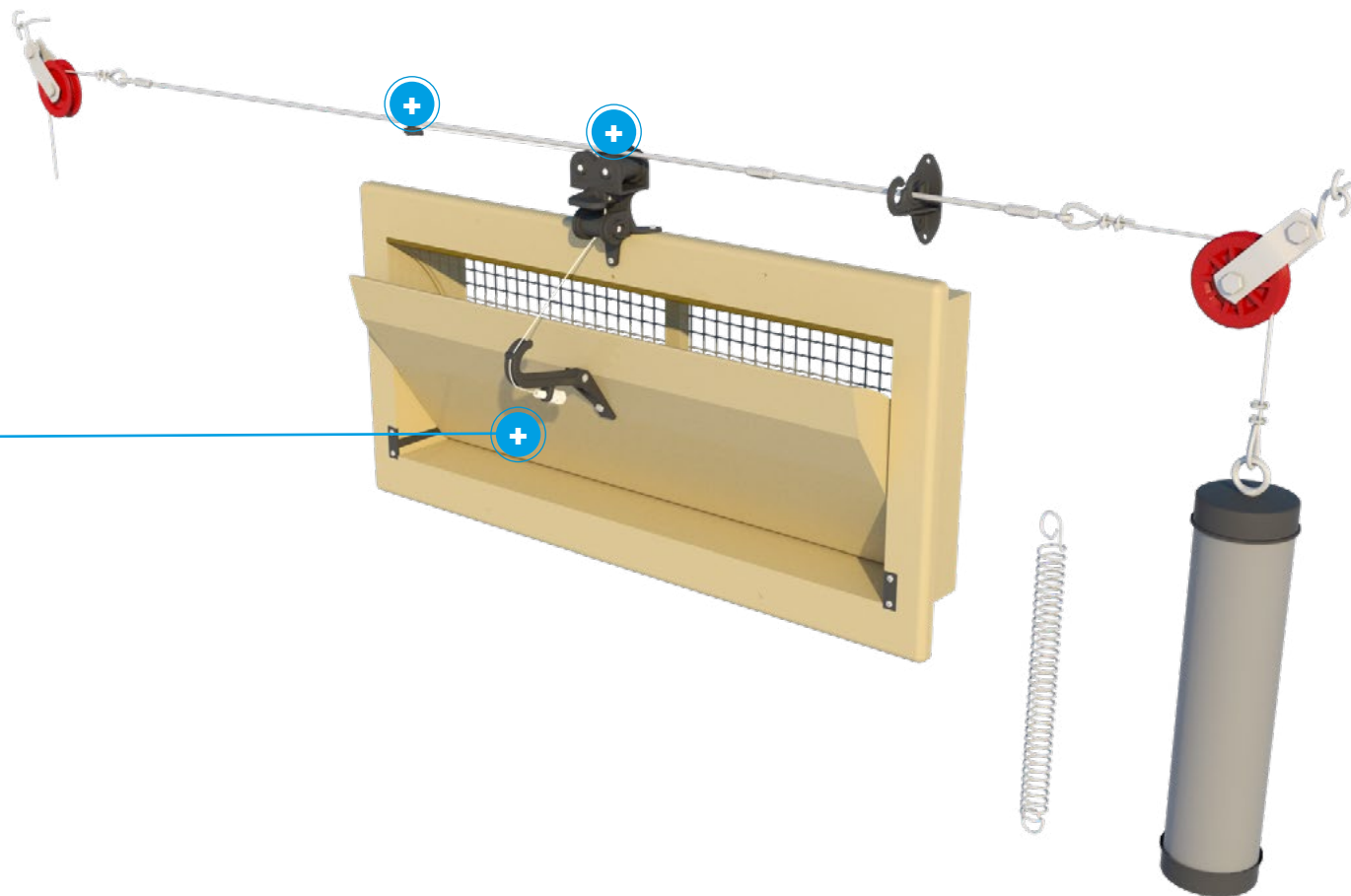
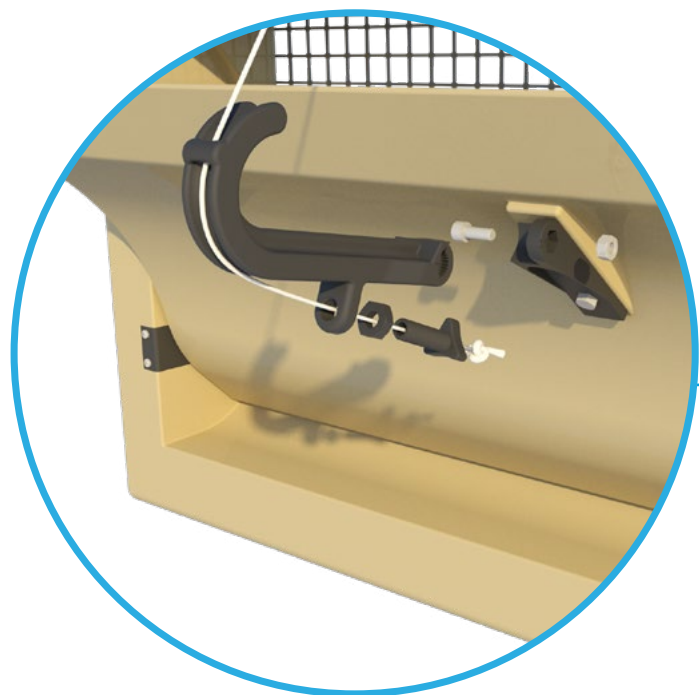

Arm angle position : 3

All sizes are in cm and inches

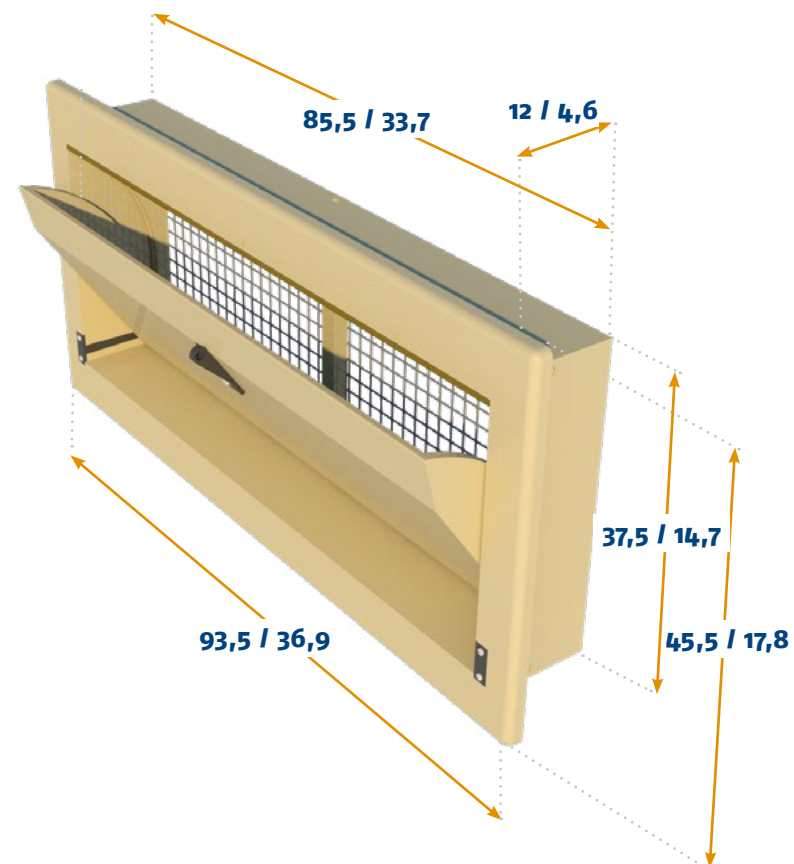
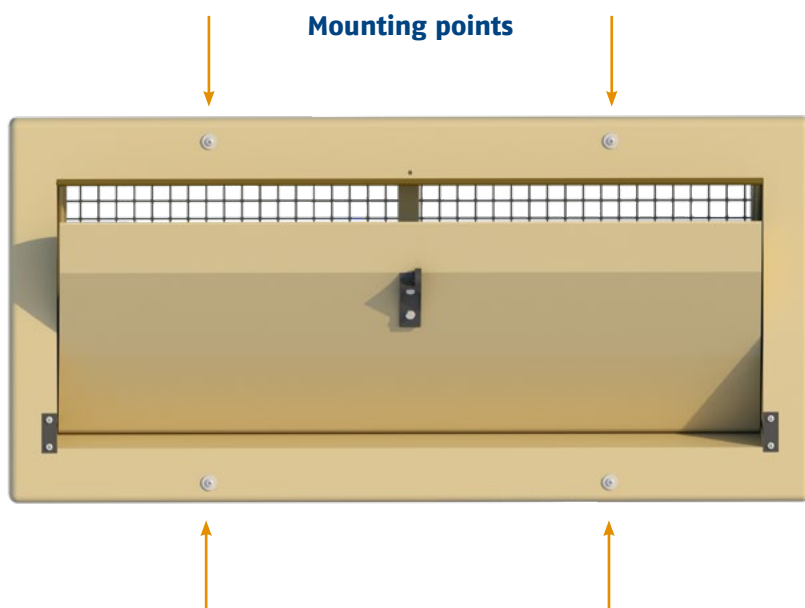

MOUNTING

Mounting type	Wall
Mounting hole size	87,5 cm / 34,5 inch x 39,5 cm / 15,5 inch

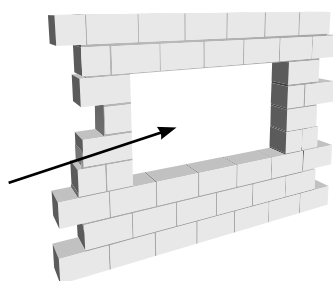

INFO

DATASHEET

ASSEMBLY

MOUNTING

WORKING

MAINTENANCE



AIR FLOW

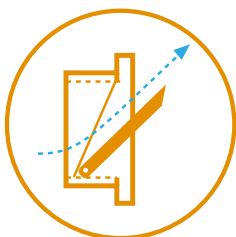

Bottom hinged inlet

This bottom hinged inlet is made to guide air over the inner flap upwards into the house. This inlet is perfectly suitable for colder climates where air is not meant to be directed towards the animals, even during maximum ventilation.

Straight inner flap

This inlet is equipped with a straight inner flap. Straight flaps guide air in a straight upwards or horizontal direction, never downwards. This is ideal for houses where air should not be directed directly towards or over the animals during maximum ventilation.

Making adjustments

By using the nylon bolt and nut small adjustments can be made to make sure all inlets are closing and opening correctly. The nylon cable clamp and cord can also be used to make small adjustments.

Working with end-weights or springs

We offer two products which can be used to keep tension on the main cable. A PVC cylinder which can be filled with concrete or sand to act as end-weight, or a spring that holds tension on the cable.

Balanced set-up

When placing the motor winch or actuator we normally suggest to divide the inlets in two groups. It is preferable to place the winch or actuator in the middle to equally divide the forces on the main cable.

(see ventilation concepts page for an example)

Use of closing catches

The closing catch on the inlet can be used to permanently close inlets for example during pre-heating. The closing catches can also be used to close certain inlets while continuing to use others. In that case the used inlets can be opened a bit further. In colder climates this can help to offer better resistance to freezing effects.

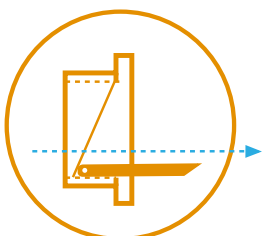

INFO

DATASHEET

ASSEMBLY

MOUNTING

WORKING

MAINTENANCE



3000-VFBG-C

This inlet suitable mostly for poultry. Equipped with a bottom hinged and curved inner valve the air is guided downwards to the animals during maximum ventilation. The inner valve and house of this inlet are equipped with seals all around to prevent air leakage. Curved inner corners in the house make for a better air flow. The combination of materials and air seals help to make this inlet perfectly suitable for use in extremely low temperatures.

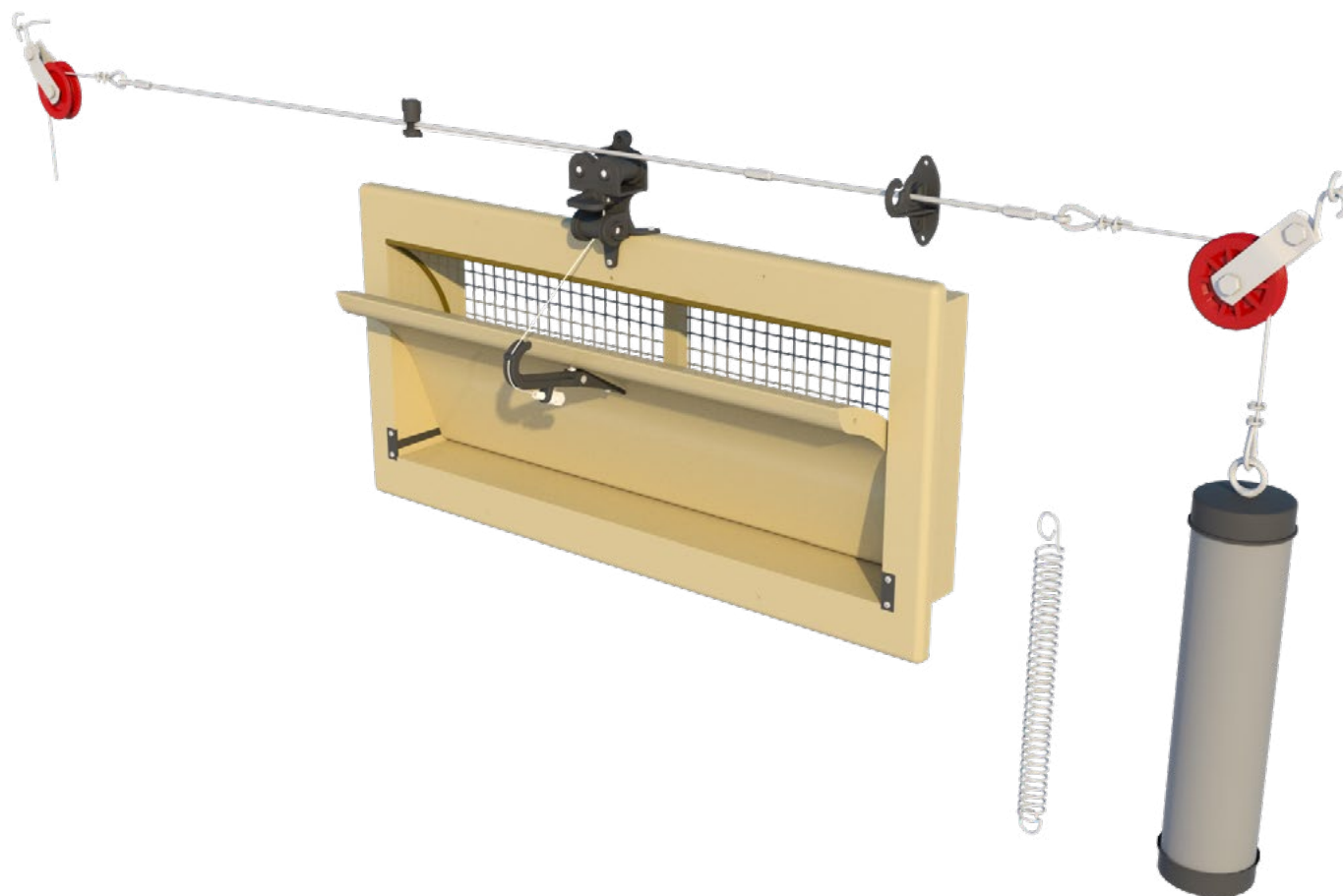

INFO

DATASHEET

ASSEMBLY

MOUNTING

WORKING

MAINTENANCE





3000-VFBG-C DATASHEET



CAPACITY

Model	m ³ /h @ 10 Pa	m ³ /h @ 20 Pa	m ³ /h @ 40 Pa
3000-VFBG-C	2900	4100	5800
	cfm @ 0.05 inH ₂ O	cfm @ 0.1 inH ₂ O	cfm @ 0.15 inH ₂ O
	1908	2693	3297

INFORMATION

Run	51 cm / 20.1 inch
Force	2 kg / 19.6 Newton
Number / pallet (1,30 x 1,00 x 2,50m / 51 x 39 x 98inch)	42
Weight / per inlet	4,1 kg / 9 lbs
Volume / per box	21
Arm position	3+

OPTIONAL ACCESSORIES

TPI-103	Wire mesh synthetic
TPI-204c	Connection set
TPI-423	Pulley Unit + Closing Catch
TPI-704	Counter flange for inlets in 3000-series

AIR FLOW

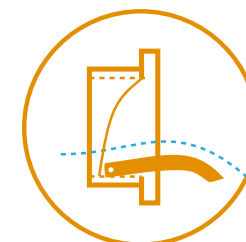
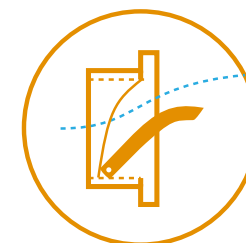

INFO

DATASHEET

ASSEMBLY

MOUNTING

WORKING

MAINTENANCE





TPI-204C

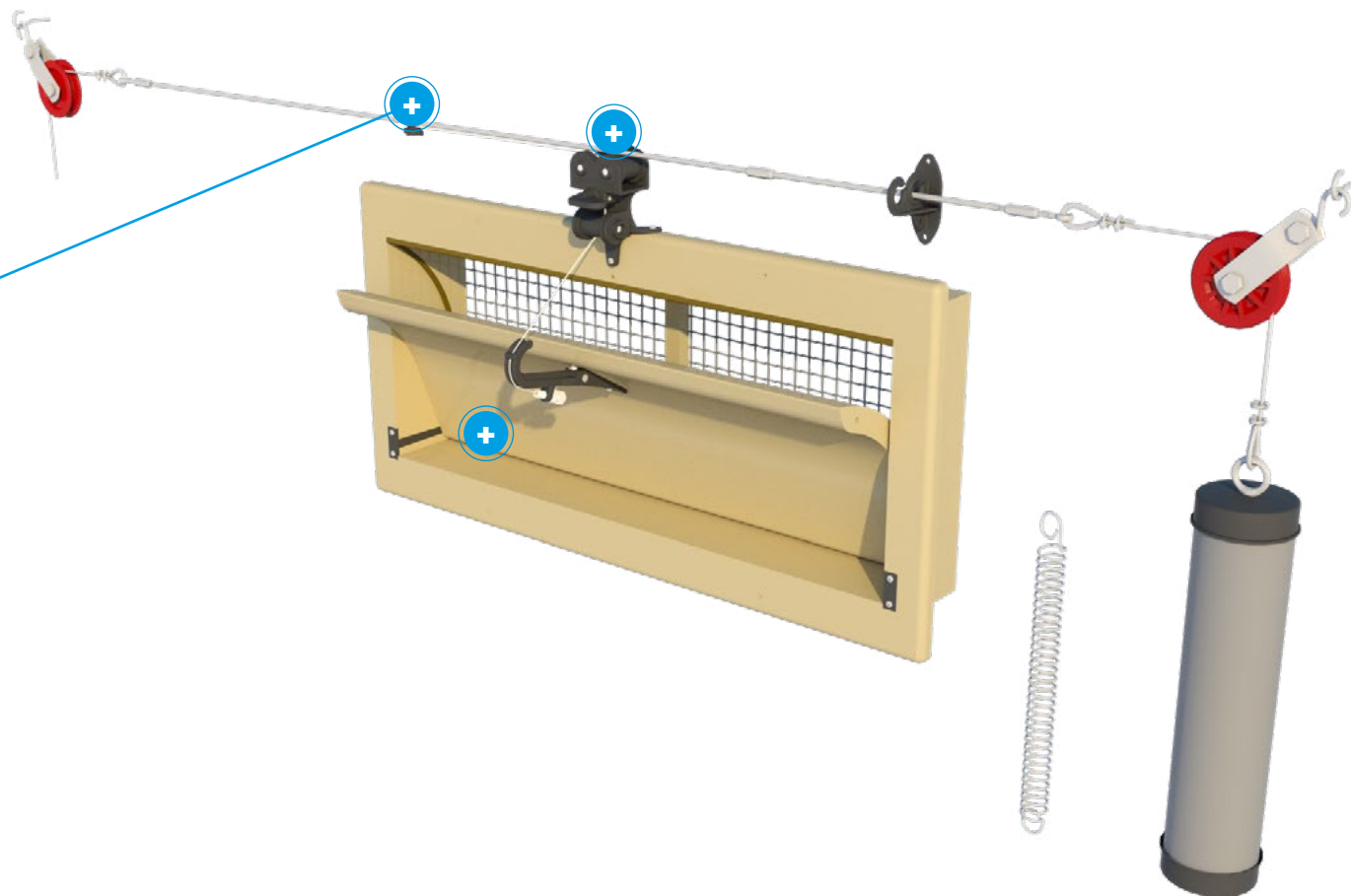

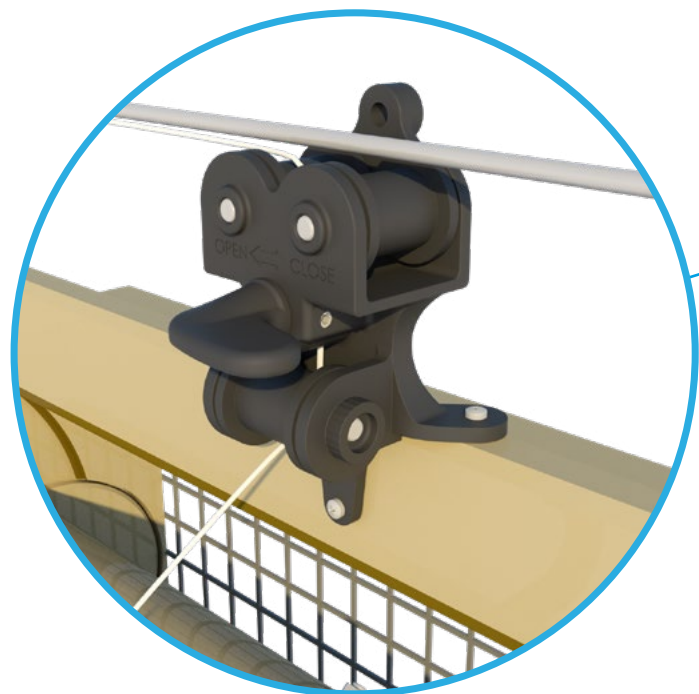

TPI-423

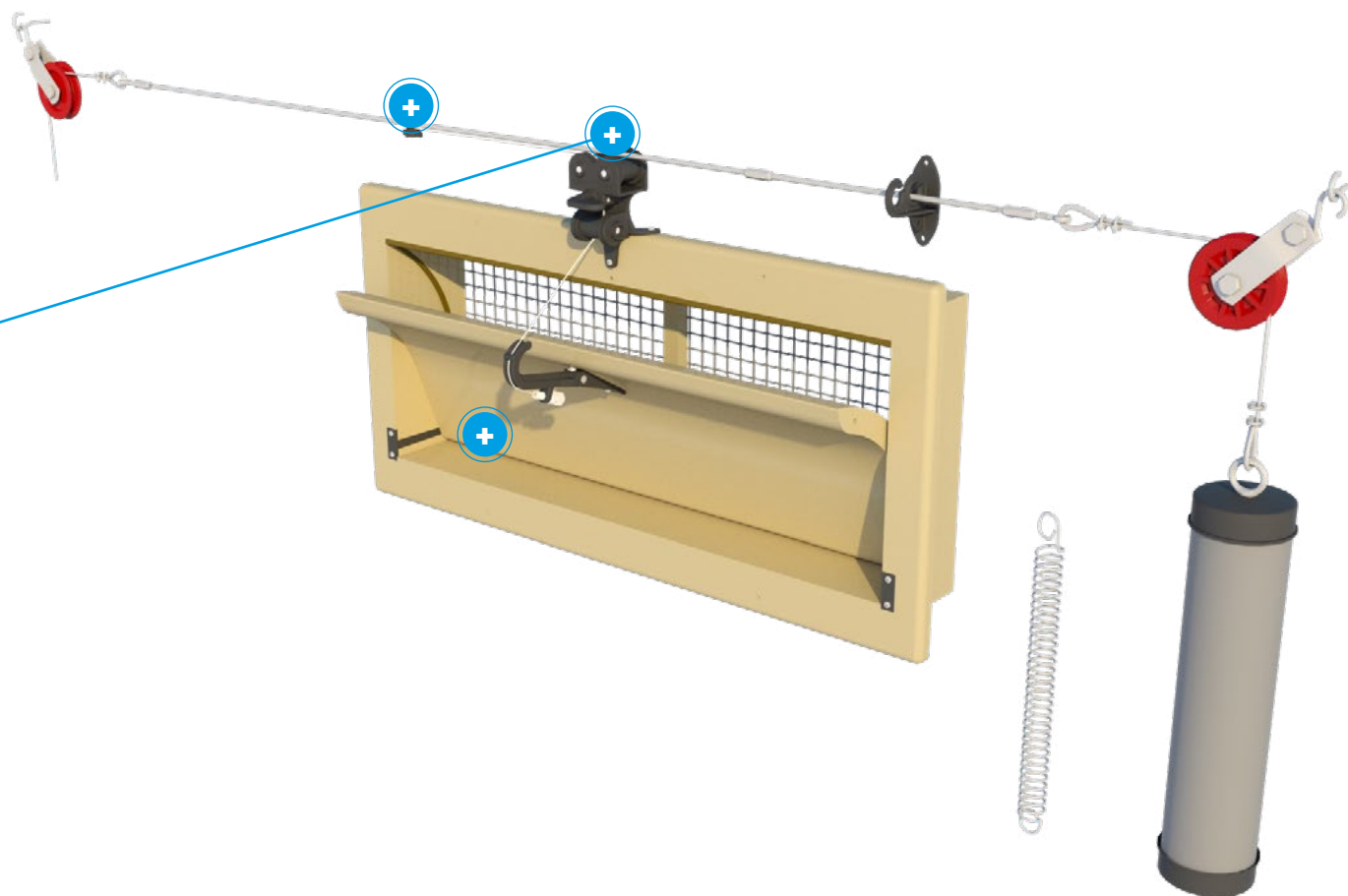

INFO

DATASHEET

ASSEMBLY

MOUNTING

WORKING

MAINTENANCE



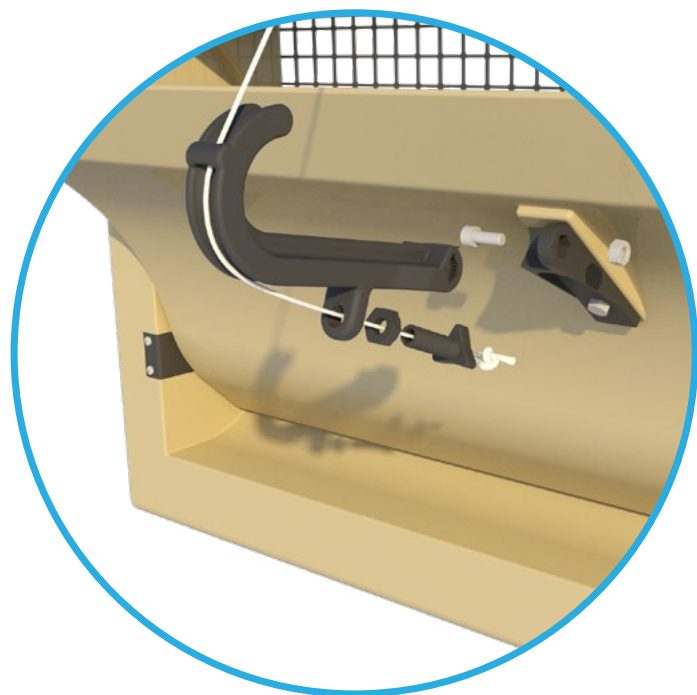

Arm angle position : 3

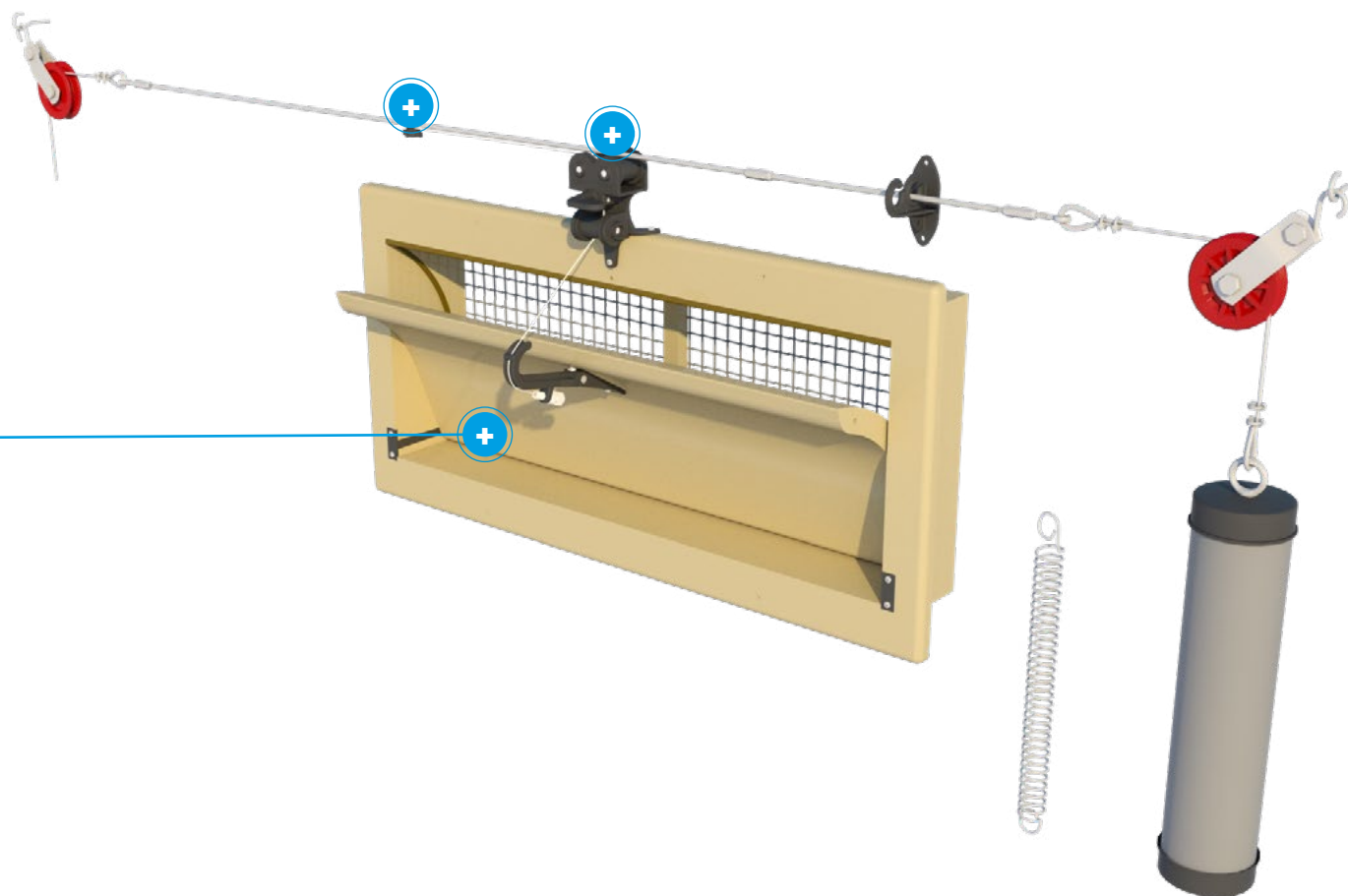

INFO

DATASHEET

ASSEMBLY

MOUNTING

WORKING

MAINTENANCE



All sizes are in cm and inches

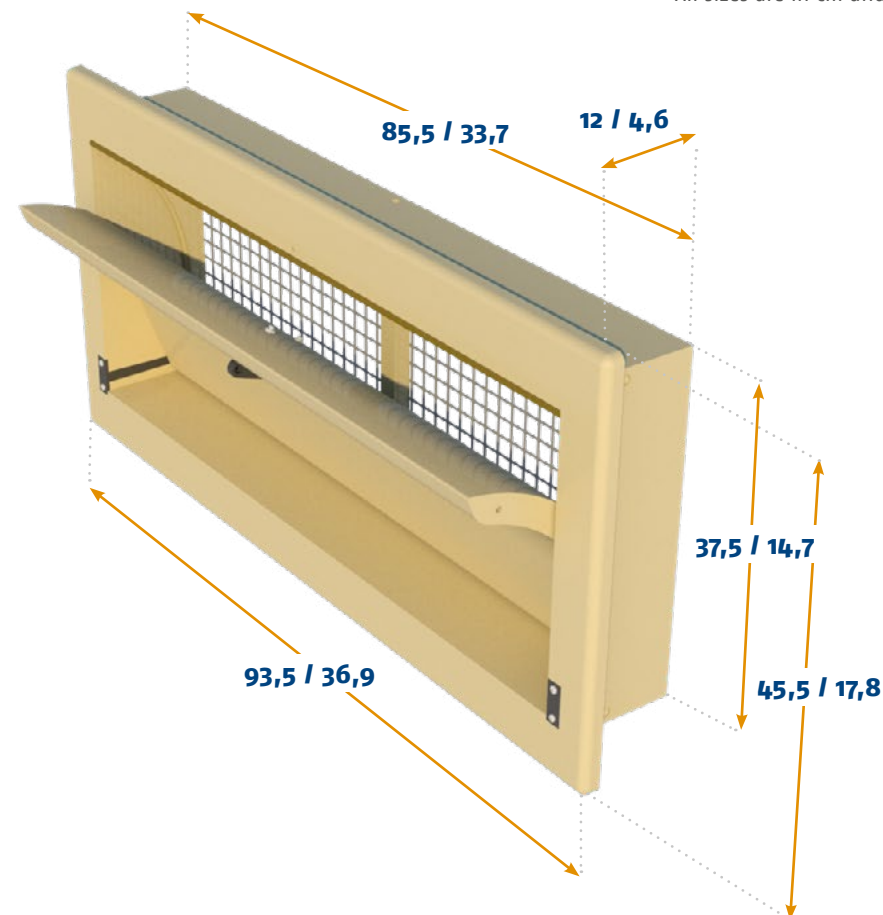
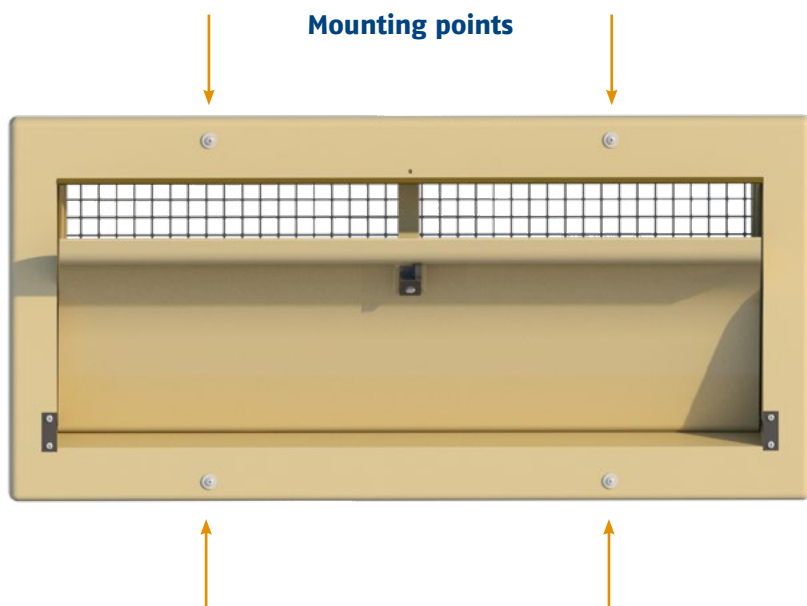

MOUNTING

Mounting type	Wall
Mounting hole size	87,5 cm / 34,45 inch x 39,5 cm / 15,55 inch

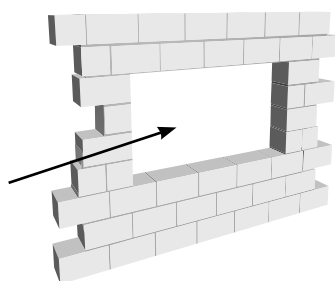

[INFO](#)

[DATASHEET](#)

[ASSEMBLY](#)

[MOUNTING](#)

[WORKING](#)

[MAINTENANCE](#)



AIR FLOW

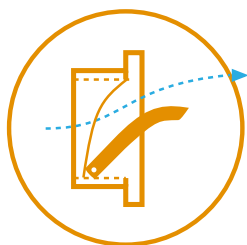

Bottom hinged inlet

This bottom hinged inlet is made to guide air over the inner flap upwards into the house. This inlet is perfectly suitable for colder climates where air is not meant to be directed towards the animals, even during maximum ventilation.

Curved inner flap

This inlet is equipped with a curved inner flap. Curved flaps guide the air upwards during minimum ventilation, but also downwards after a certain point of opening. This is ideal for houses where air should be directed directly towards or over the animals during maximum ventilation.

Making adjustments

By using the nylon bolt and nut small adjustments can be made to make sure all inlets are closing and opening correctly. The nylon cable clamp and cord can also be used to make small adjustments.

Working with end-weights or springs

We offer two products which can be used to keep tension on the main cable. A PVC cylinder which can be filled with concrete or sand to act as end-weight, or a spring that holds tension on the cable.

Balanced set-up

When placing the motor winch or actuator we normally suggest to divide the inlets in two groups. It is preferable to place the winch or actuator in the middle to equally divide the forces on the main cable.

(see ventilation concepts page for an example)

Use of closing catches

The closing catch on the inlet can be used to permanently close inlets for example during pre-heating. The closing catches can also be used to close certain inlets while continuing to use others. In that case the used inlets can be opened a bit further. In colder climates this can help to offer better resistance to freezing effects.



INFO

DATASHEET

ASSEMBLY

MOUNTING

WORKING

MAINTENANCE



4000-VFG-C

This inlet is suitable for almost all applications. With a middle hinged inner valve the air will be divided and also flows underneath the valve when it is opened over 25%. The inlet is controlled by means of a central plastic control arm. This inlet is executed with a curved inner valve so when it is opened for maximum ventilation air is also guide downwards to the animals. The square shape and slightly curved inner valve of this inlet make it especially suitable for wider houses where a farther throw of air is desirable.

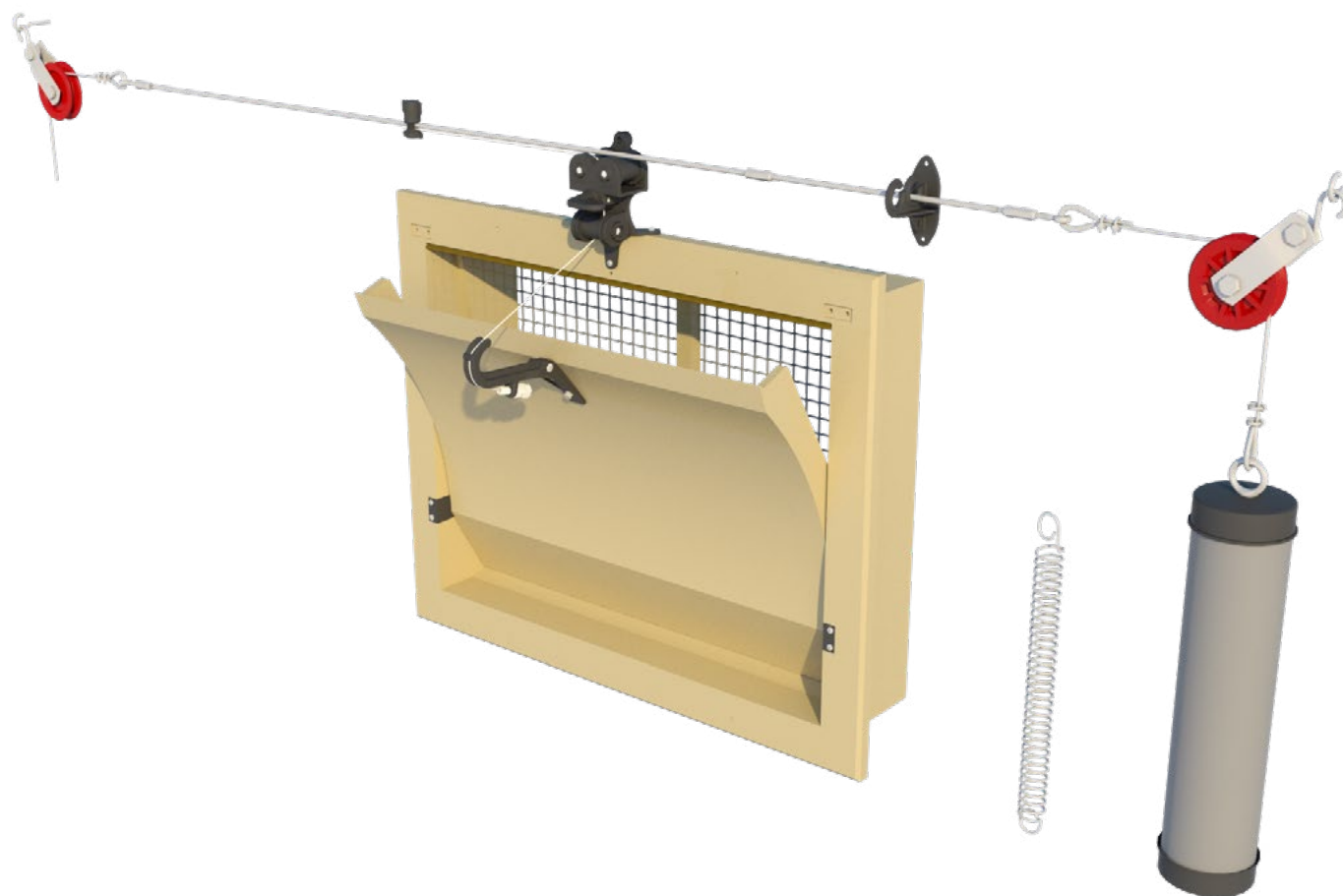

INFO

DATASHEET

ASSEMBLY

MOUNTING

WORKING

MAINTENANCE





4000-VFG-C DATASHEET



CAPACITY

Model	m ³ /h @ 10 Pa	m ³ /h @ 20 Pa	m ³ /h @ 40 Pa
4000-VFG-C	3900	5500	7800
	cfm @ 0.05 inH ₂ O	cfm @ 0.1 inH ₂ O	cfm @ 0.15 inH ₂ O
	2566	3612	4433

INFORMATION

Run	63 cm / 24.6 inch
Force	2,78 kg / 27.2 Newton
Number / pallet (1,20 x 0,80 x 2,40m / 47 x 31,5 x 94,5inch)	18
Weight / per inlet	4 kg / 8,8 lbs
Volume / per box	9
Arm position	2

OPTIONAL ACCESSORIES

TPI-108	Wire mesh synthetic
TPI-204c	Connection set
TPI-423	Pulley Unit + Closing Catch
TPI-705	Counter flange for inlets in 4000-series

AIR FLOW

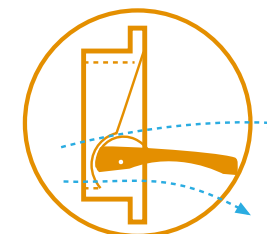
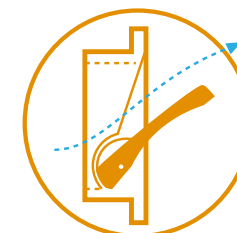

INFO

DATASHEET

ASSEMBLY

MOUNTING

WORKING

MAINTENANCE





TPI-204C

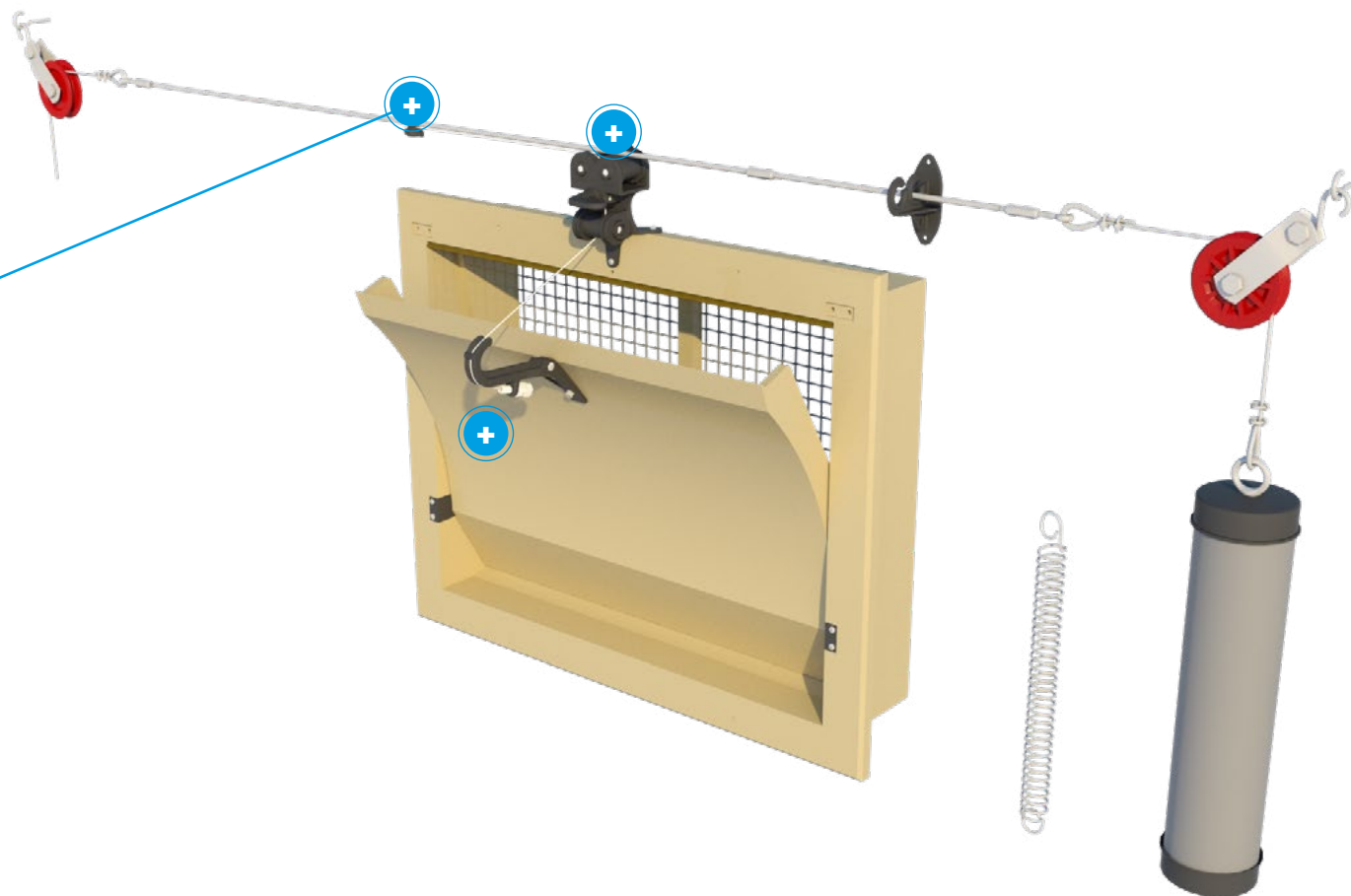

INFO

DATASHEET

ASSEMBLY

MOUNTING

WORKING

MAINTENANCE



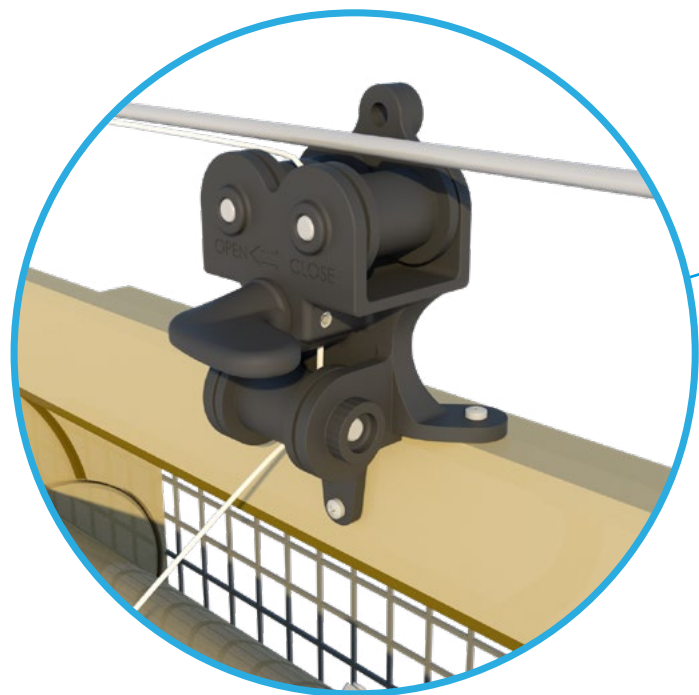

TPI-423

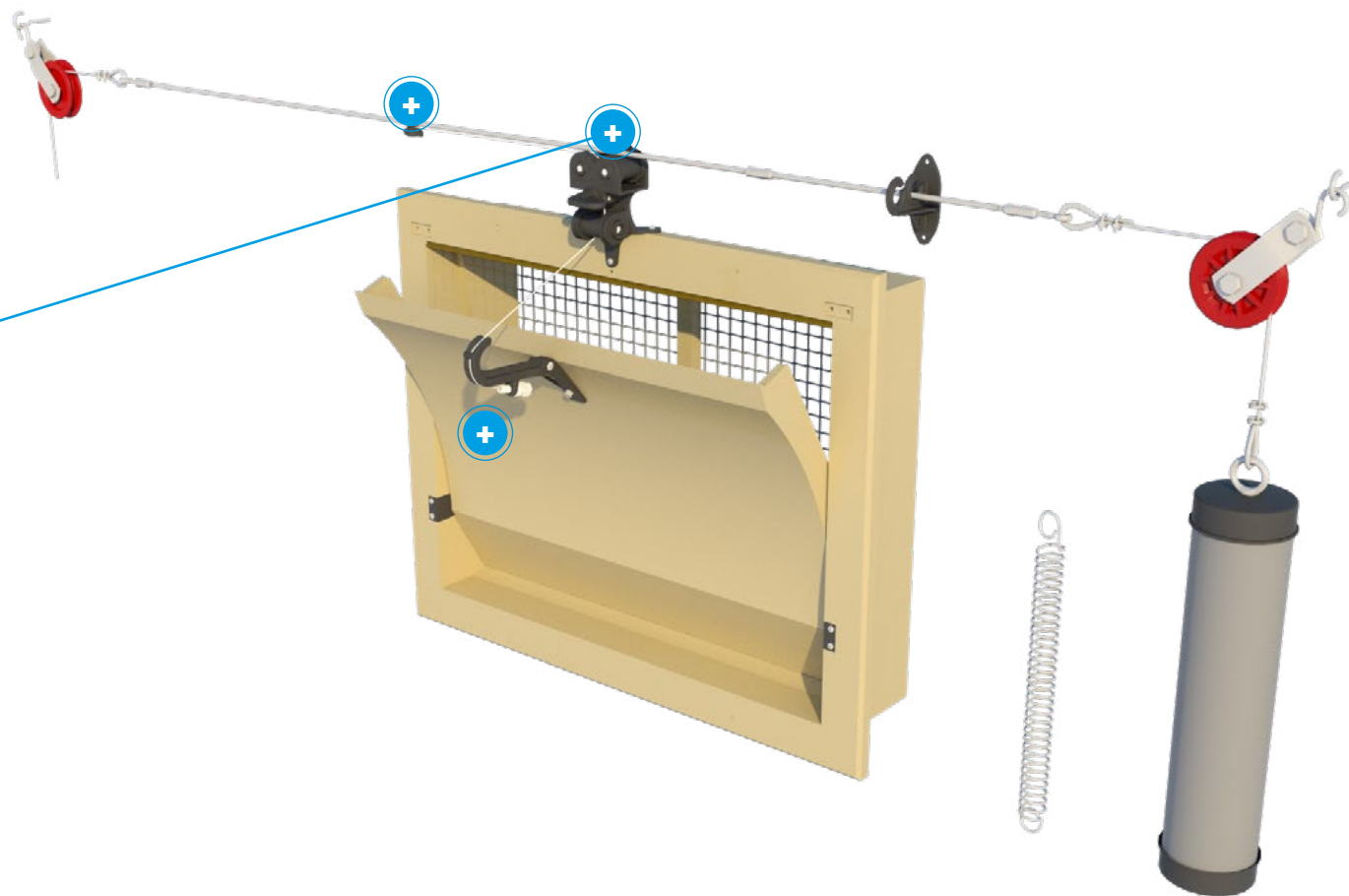

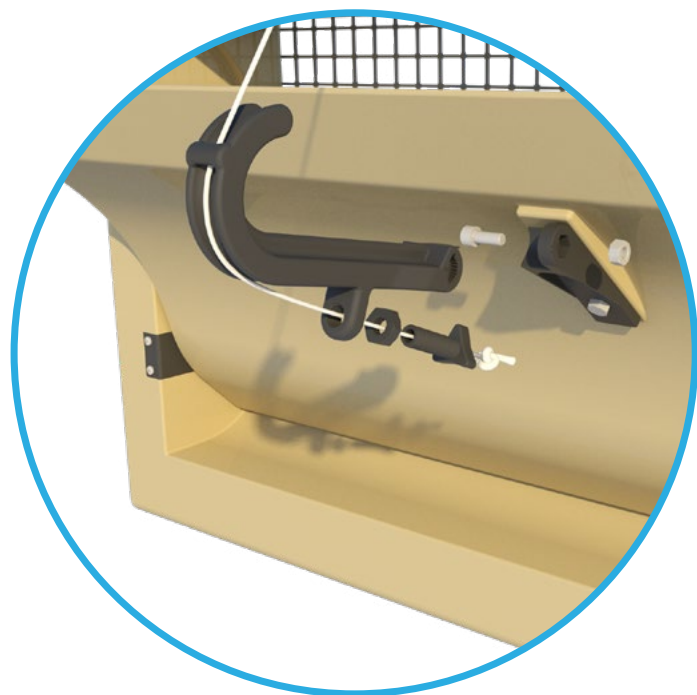

Arm angle position : 2

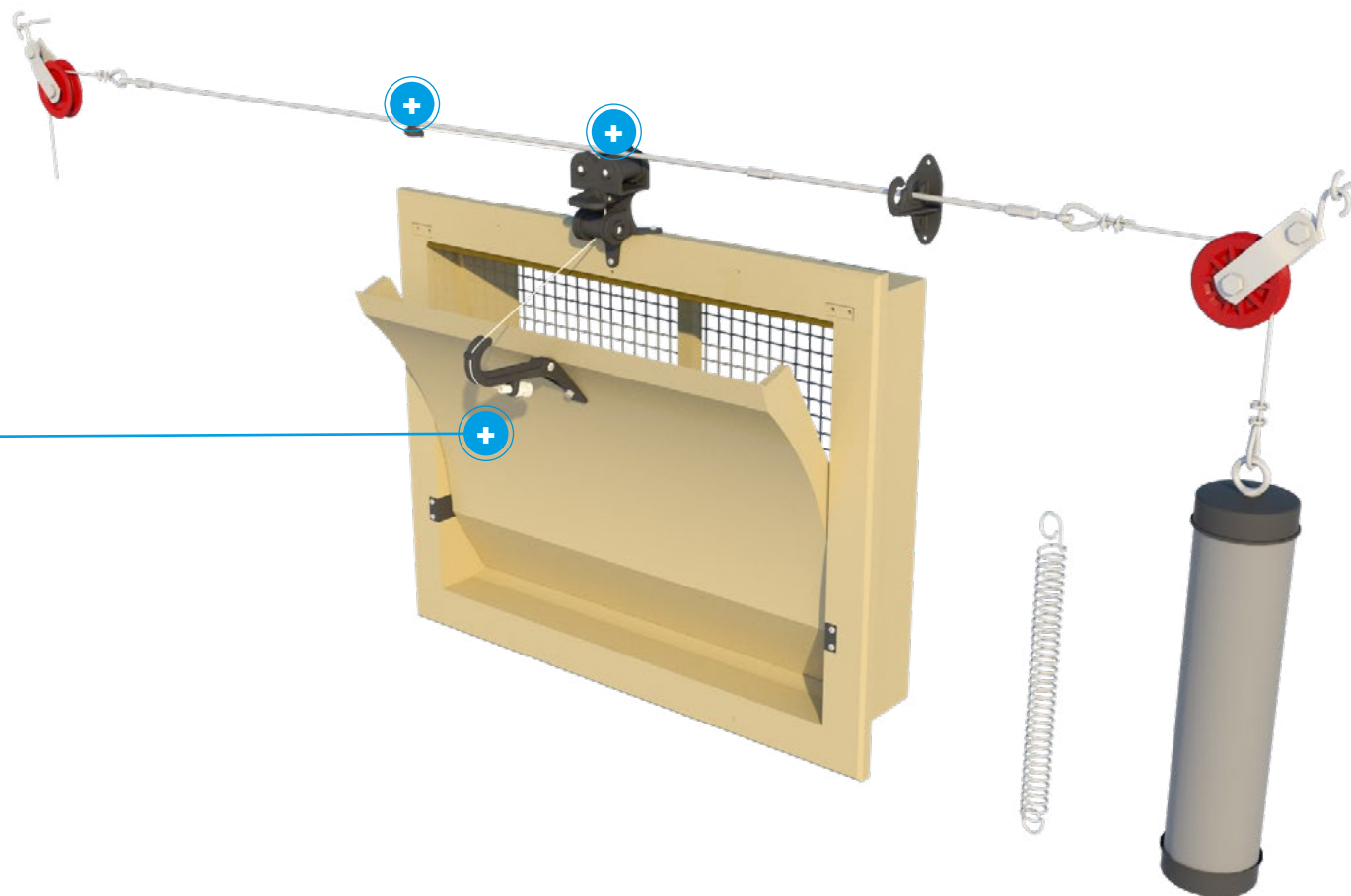

INFO

DATASHEET

ASSEMBLY

MOUNTING

WORKING

MAINTENANCE



All sizes are in cm and inches

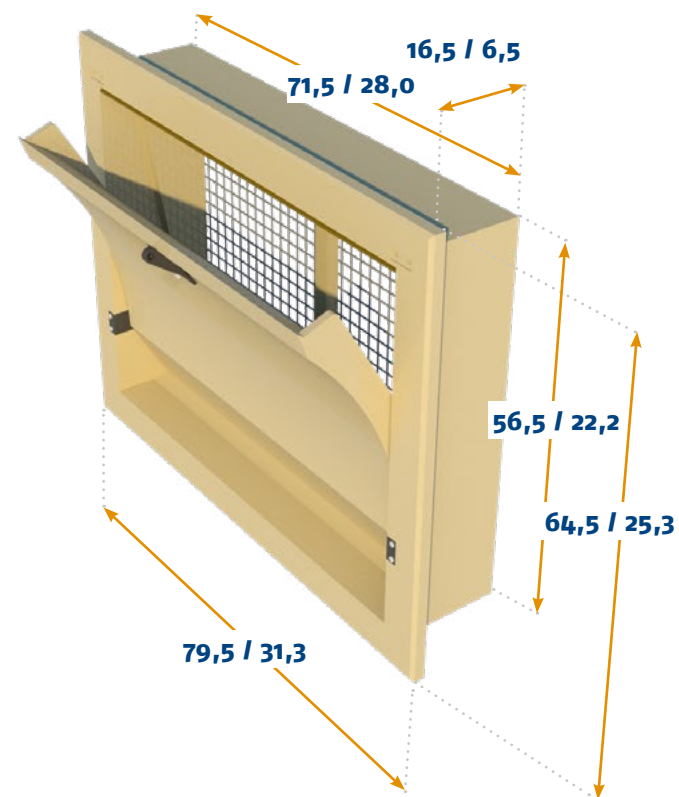
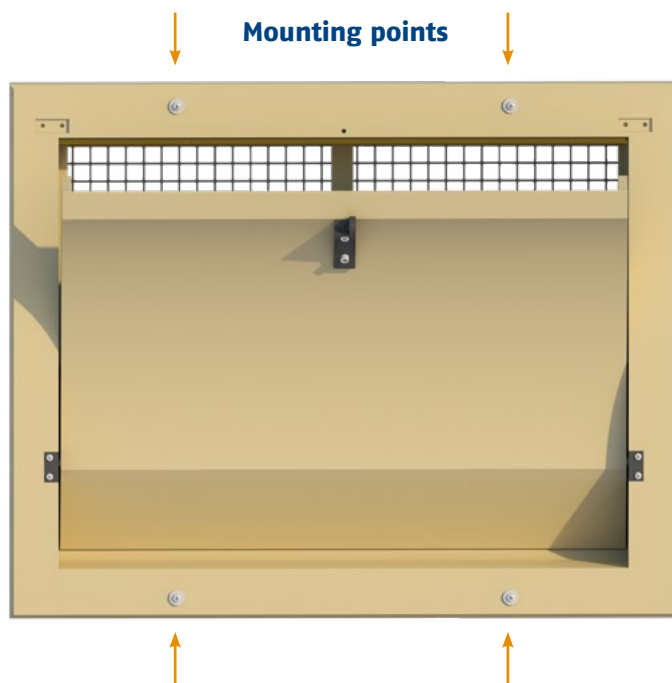

MOUNTING

Mounting type	Wall
Mounting hole size	73 cm / 28,82 inch x 58 cm / 23 inch

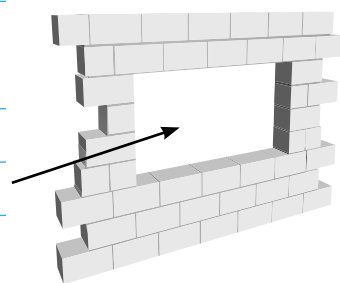

INFO

DATASHEET

ASSEMBLY

MOUNTING

WORKING

MAINTENANCE



AIR FLOW

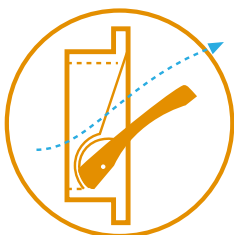

Middle hinged inlet

This middle hinged inlet is made to allow air to also flow underneath the inner flap after opening further than 35%. This helps to guide air downwards to the animals and provide a cooling effect during maximum ventilation.

Curved inner flap

This inlet is equipped with a curved inner flap. Curved flaps guide the air upwards during minimum ventilation, but also downwards after a certain point of opening. This is ideal for houses where air should be directed directly towards or over the animals during maximum ventilation.

Making adjustments

By using the nylon bolt and nut small adjustments can be made to make sure all inlets are closing and opening correctly. The nylon cable clamp and cord can also be used to make small adjustments.

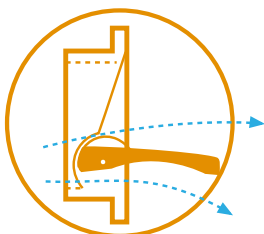

Working with end-weights or springs

We offer two products which can be used to keep tension on the main cable. A PVC cylinder which can be filled with concrete or sand to act as end-weight, or a spring that holds tension on the cable.

Balanced set-up

When placing the motor winch or actuator we normally suggest to divide the inlets in two groups. It is preferable to place the winch or actuator in the middle to equally divide the forces on the main cable.

(see ventilation concepts page for an example)

Use of closing catches

The closing catch on the inlet can be used to permanently close inlets for example during pre-heating. The closing catches can also be used to close certain inlets while continuing to use others. In that case the used inlets can be opened a bit further. In colder climates this can help to offer better resistance to freezing effects.

[INFO](#)
[DATASHEET](#)
[ASSEMBLY](#)
[MOUNTING](#)
[WORKING](#)
[MAINTENANCE](#)

OMNIFLUX

This inlet is developed for use in very wide houses or houses with obstacles. Due to the adjustable louvres the air flow can be directed in any desired direction independent of the required capacity. With unique sliders and guide rails we make sure the profiled sliding plate of the inlet never gets stuck. Two quick-release clamps at the bottom of the guide rails allow a quick removal of the plate for cleaning purposes. The Pulley Unit created for this inlet has an internal cord lock to lock the inlets when needed.



[INFO](#)

[DATASHEET](#)

[ASSEMBLY](#)

[MOUNTING](#)

[WORKING](#)

[MAINTENANCE](#)



CAPACITY

Model	m ³ /h @ 10 Pa	m ³ /h @ 20 Pa	m ³ /h @ 40 Pa	
Omniflux 3200	3200	4450	6400	Horizontally
Omniflux 2250	2250	3200	4450	30°,1 Direction
Omniflux 2150	2150	3000	4350	30°,2 Direction
	cfm @ 0.05 inH ₂ O	cfm @ 0.1 inH ₂ O	cfm @ 0.15 inH ₂ O	
Omniflux 2106	2106	2922	3638	Horizontally
Omniflux 1481	1481	2102	2529	30°,1 Direction
Omniflux 1415	1415	1970	2472	30°,2 Direction

AIR FLOW

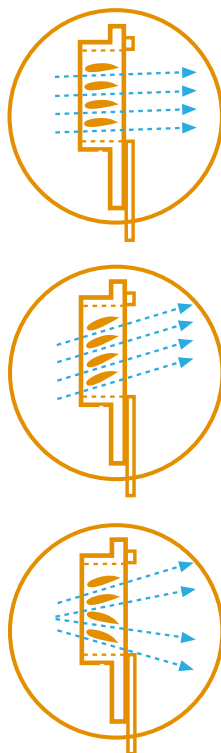

OPTIONAL ACCESSORIES

TPI-117	Wire mesh synthetic
TPI-204c	Connection set
TPI-422	Pulley Unit

INFORMATION

Run	42 cm / 16.5 inch
Force	4,5 kg / 44.1 Newton
Number / pallet (1,20 x 1,00 x 2,40m / 47 x 39 x 94,5inch)	22
Weight / per inlet	5,2 kg / 11.5 lbs
Volume / per box	11

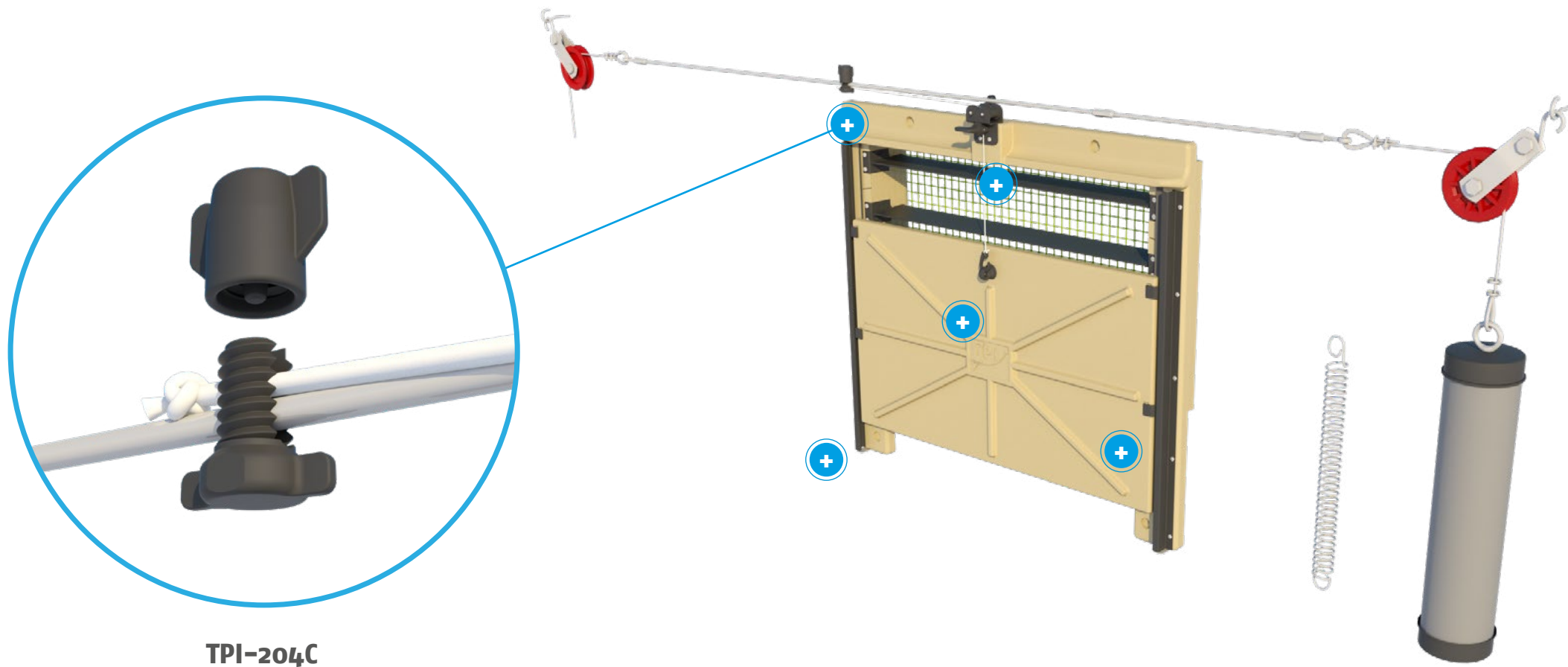

TPI-204C

INFO

DATASHEET

ASSEMBLY

MOUNTING

WORKING

MAINTENANCE



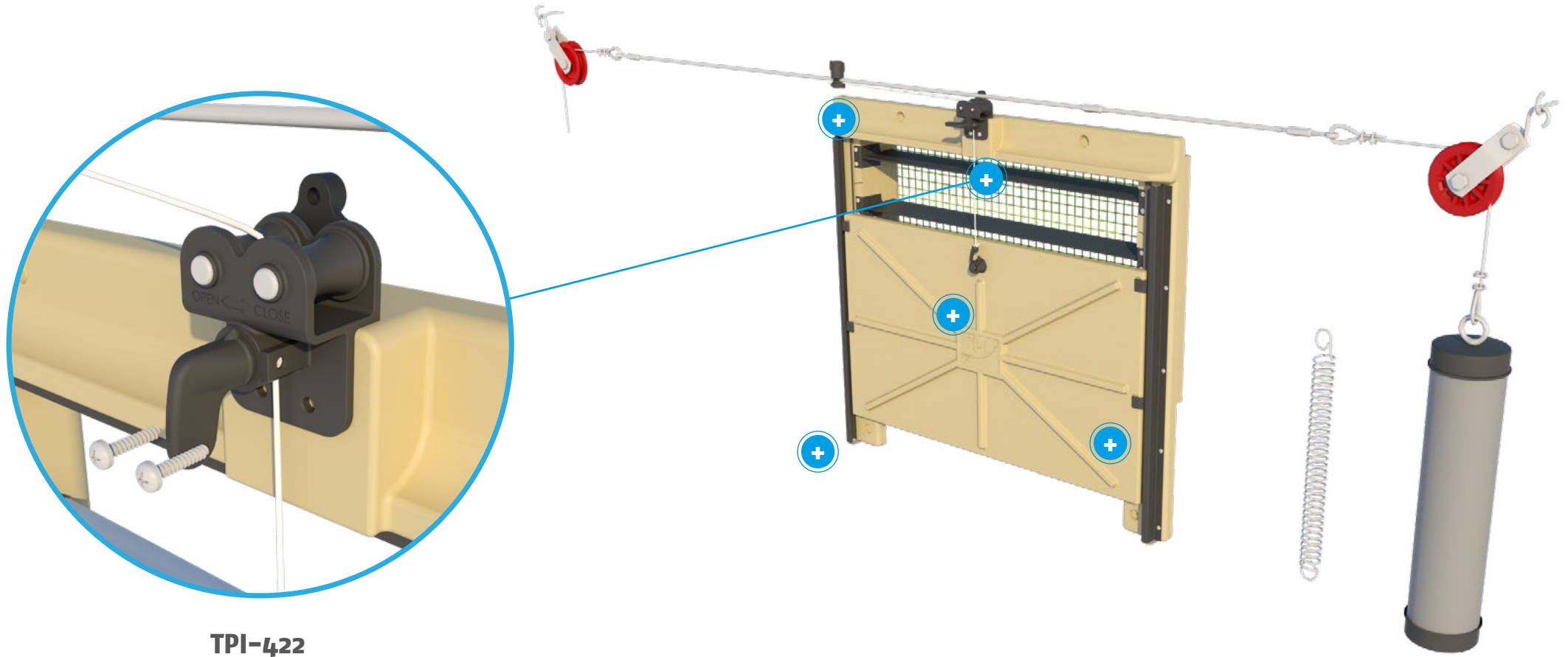

INFO

DATASHEET

ASSEMBLY

MOUNTING

WORKING

MAINTENANCE



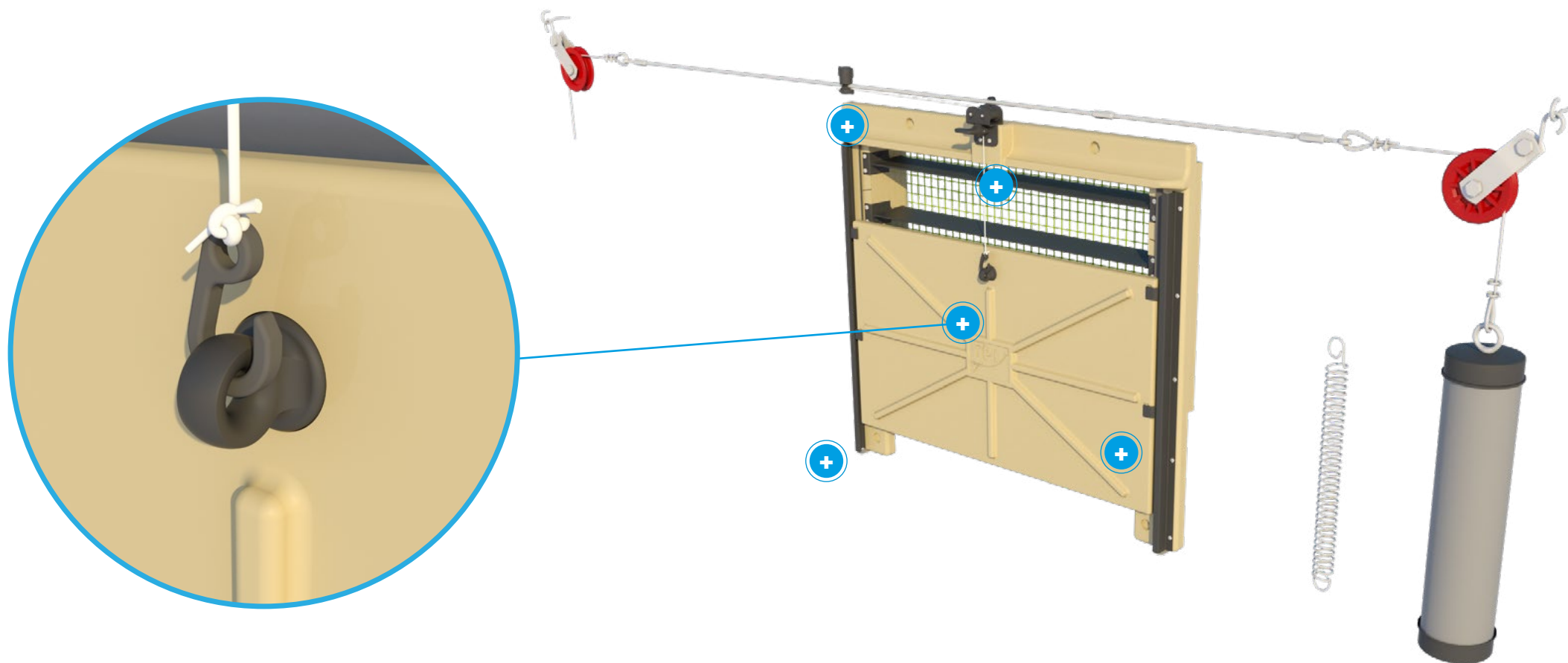

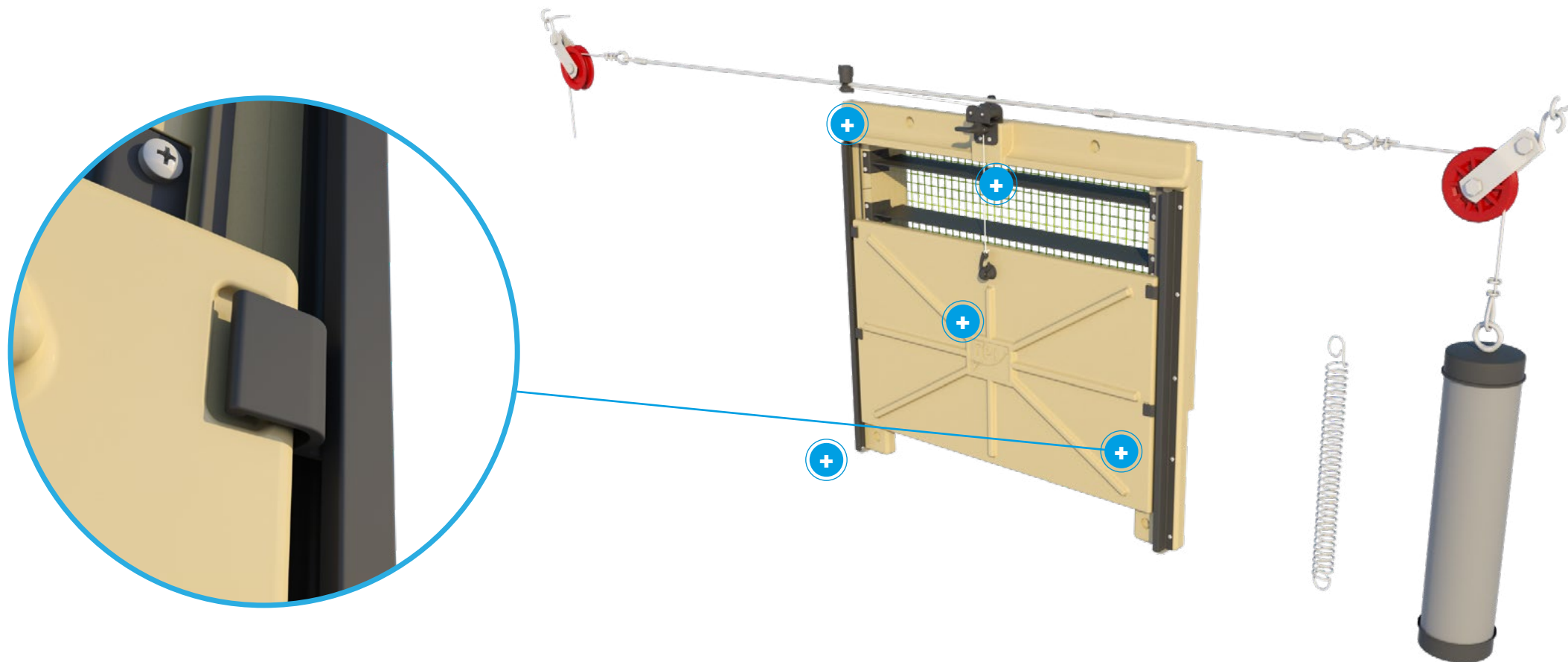

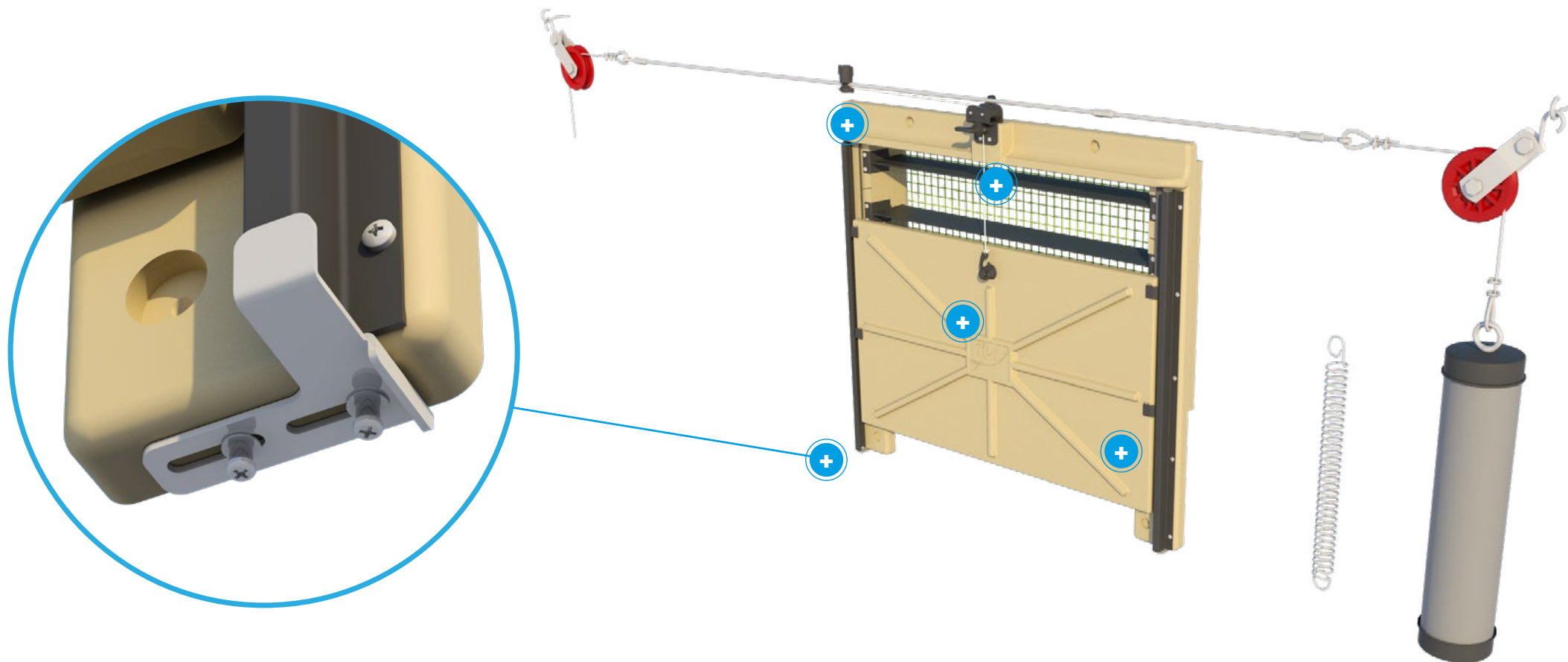

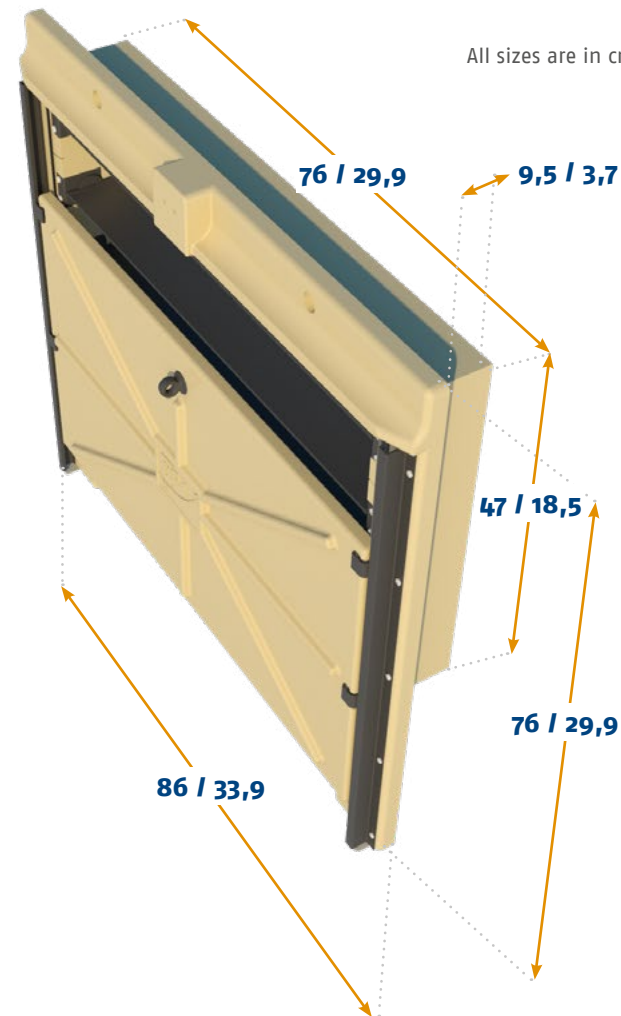
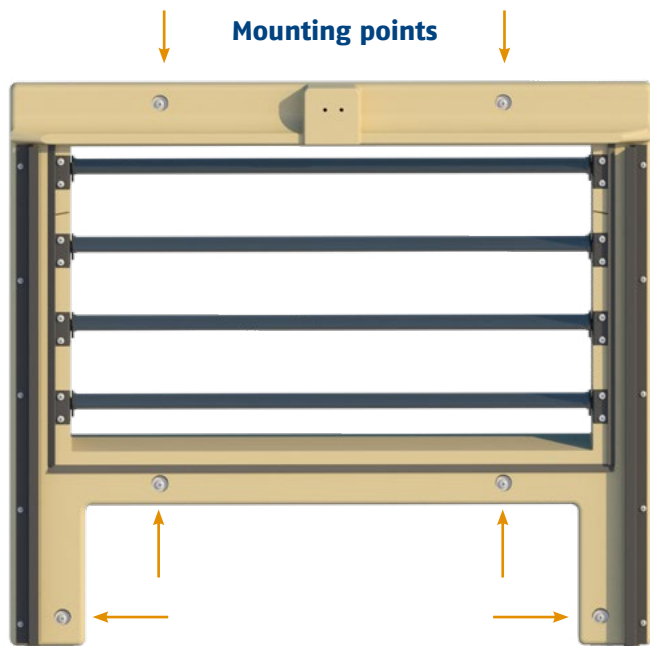

MOUNTING

Mounting type	Wall
Mounting hole size	78 cm / 30,7 inch x 49 cm / 19,3 inch

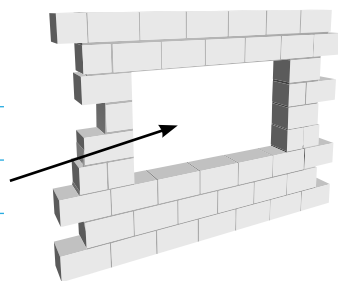

INFO

DATASHEET

ASSEMBLY

MOUNTING

WORKING

MAINTENANCE



AIR FLOW

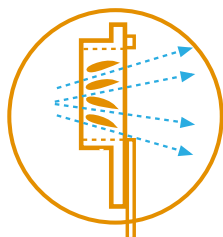
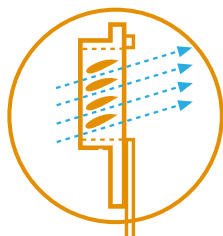
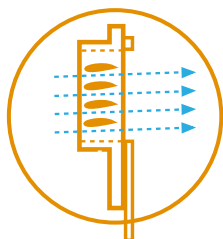

Sliding plate and louvres

Instead of using a moving flap this inlet is equipped with a sliding plate that opens or closes during ventilation. In the house of the inlet individual louvres can be positioned to guide air in whichever direction is preferred. The unique functionality of this louvre system is that air can be guided in each direction independent of the required capacity.

Working with end-weights or springs

We offer two products which can be used to keep tension on the main cable. A PVC cylinder which can be filled with concrete or sand to act as end-weight, or a spring that holds tension on the cable.

Balanced set-up

When placing the motor winch or actuator we normally suggest to divide the inlets in two groups. It is preferable to place the winch or actuator in the middle to equally divide the forces on the main cable. (see ventilation concepts page for an example)

Use of closing catches

The closing catch on the inlet can be used to permanently close inlets for example during pre-heating. The closing catches can also be used to close certain inlets while continuing to use others. In that case the used inlets can be opened a bit further. In colder climates this can help to offer better resistance to freezing effects.



INFO

DATASHEET

ASSEMBLY

MOUNTING

WORKING

MAINTENANCE



OMNISTEP

This inlet developed for use in alternative housing systems. The inlet can be positioned to guide air downwards and/or upwards by positioning the hinged plate. This inlet is made entirely out of high quality polyurethane thus offering unique insulation values. Per inlet the stance for the plate can be chosen independently, half of the inlets could guide air upwards while the other half guides air downwards.



INFO

DATASHEET

ASSEMBLY

MOUNTING

WORKING

MAINTENANCE





OMNISTEP DATASHEET



CAPACITY

Model	m ³ /h @ 10 Pa	m ³ /h @ 20 Pa	m ³ /h @ 40 Pa
Omnistep	3800	5350	7600
	cfm @ 0.05 inH ₂ O	cfm @ 0.1 inH ₂ O	cfm @ 0.15 inH ₂ O
	2501	3514	4320

INFORMATION

Run	23 cm / 9.1 inch
Force	6 kg / 58.8 Newton
Number / pallet (1,20 x 1,00 x 2,40m / 47 x 39 x 94,5inch)	20
Weight / per inlet	8,1 kg / 17.9 lbs
Volume / per box	10

OPTIONAL ACCESSORIES

TPI-115	Wire mesh synthetic
TPI-205	Connection set

AIR FLOW

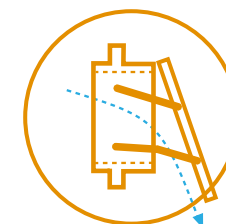
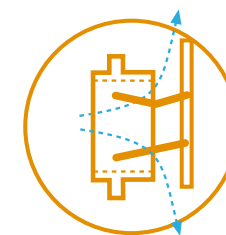
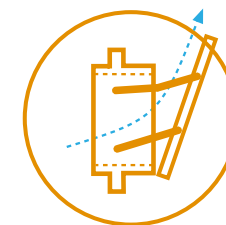

INFO

DATASHEET

ASSEMBLY

MOUNTING

WORKING

MAINTENANCE



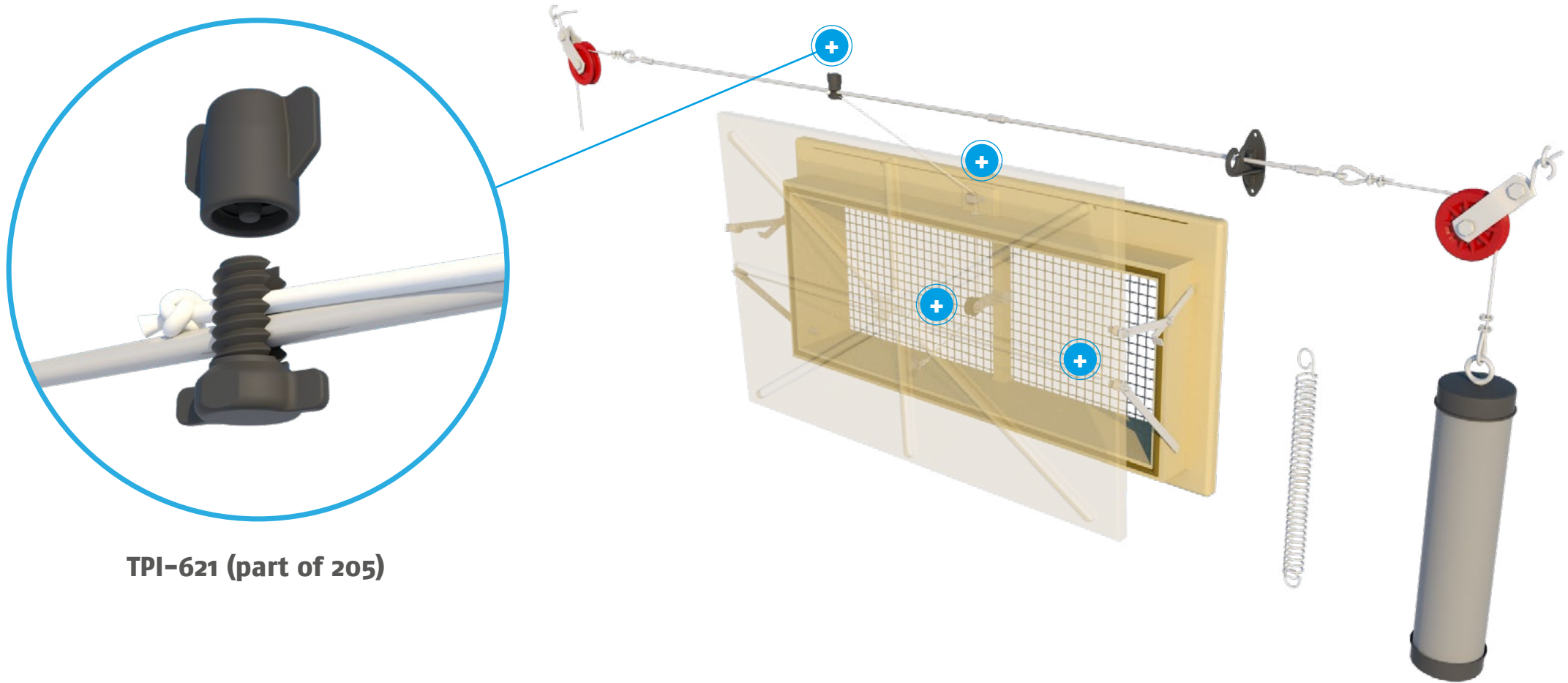

TPI-621 (part of 205)

INFO

DATASHEET

ASSEMBLY

MOUNTING

WORKING

MAINTENANCE



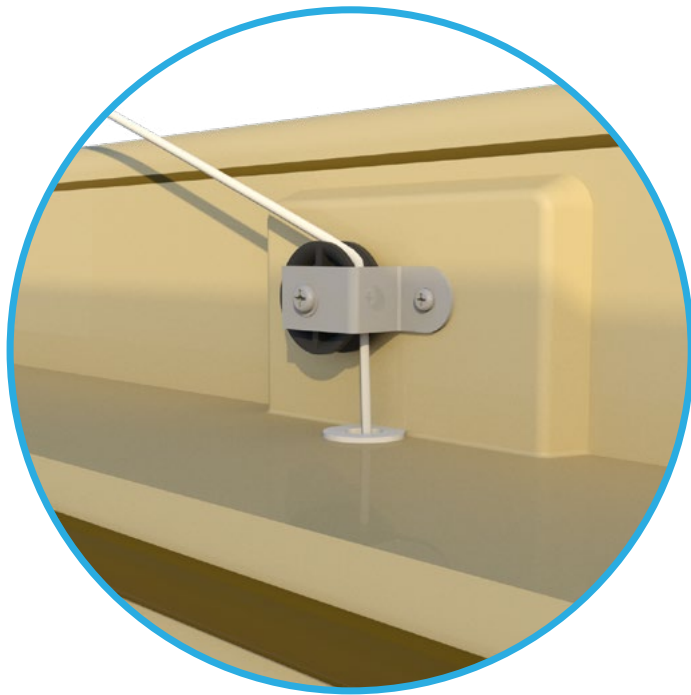

TPI-205

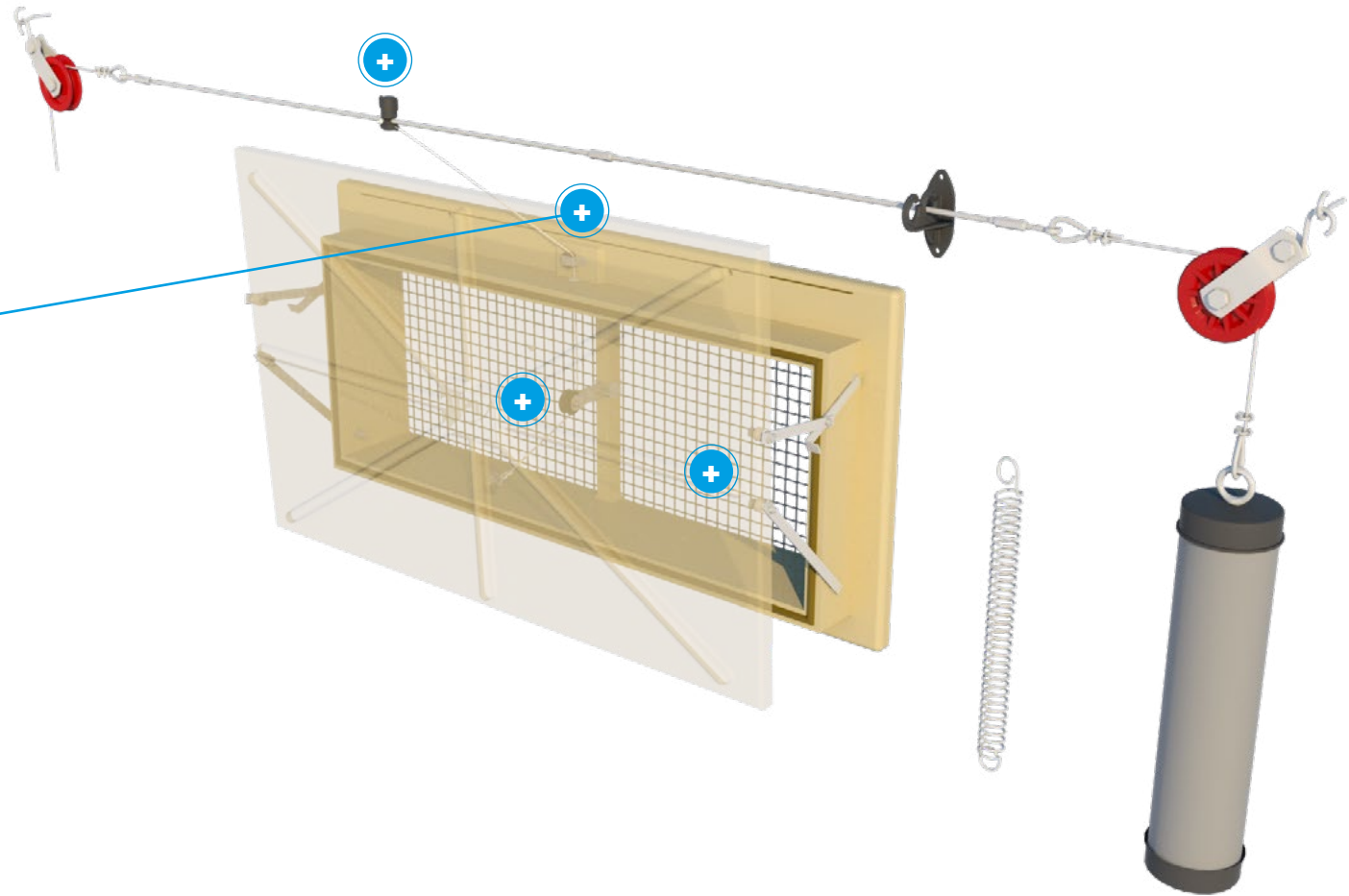

INFO

DATASHEET

ASSEMBLY

MOUNTING

WORKING

MAINTENANCE



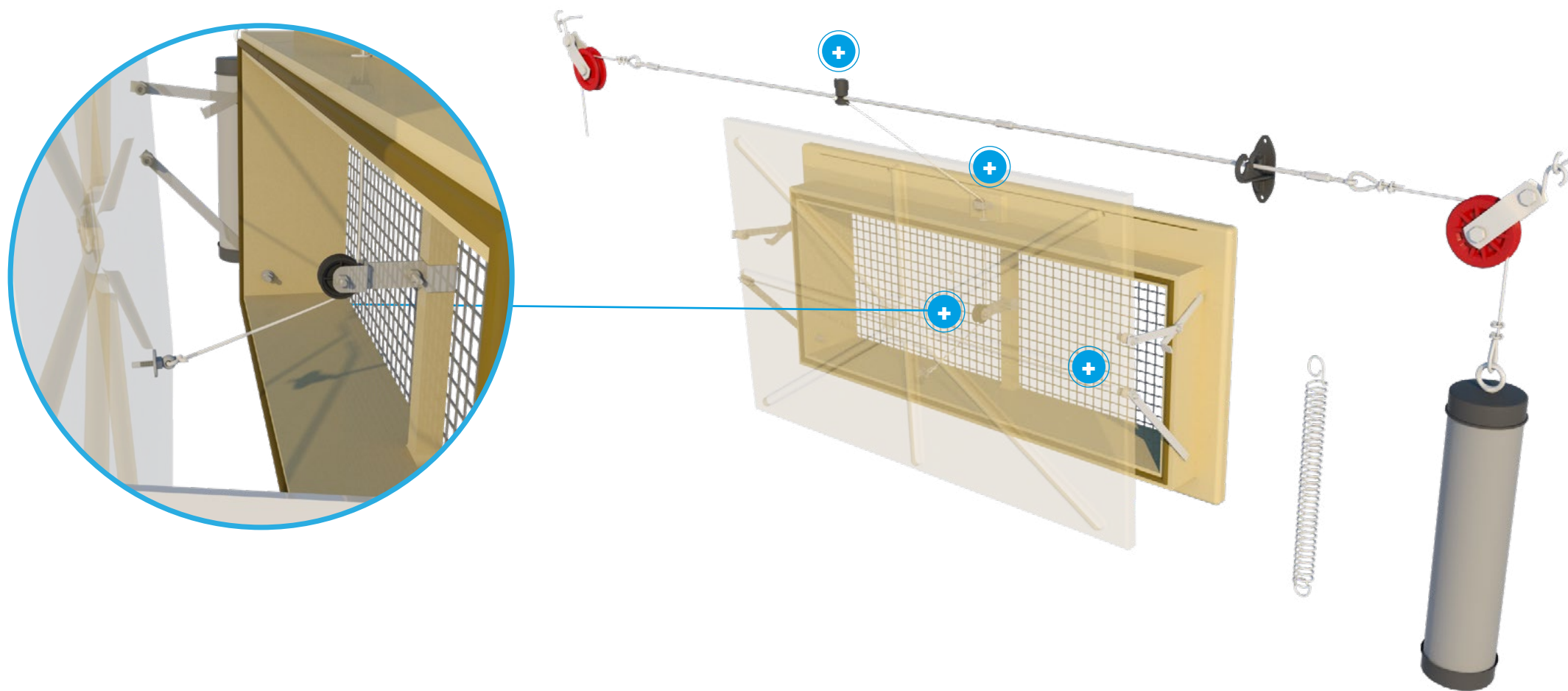

INFO

DATASHEET

ASSEMBLY

MOUNTING

WORKING

MAINTENANCE



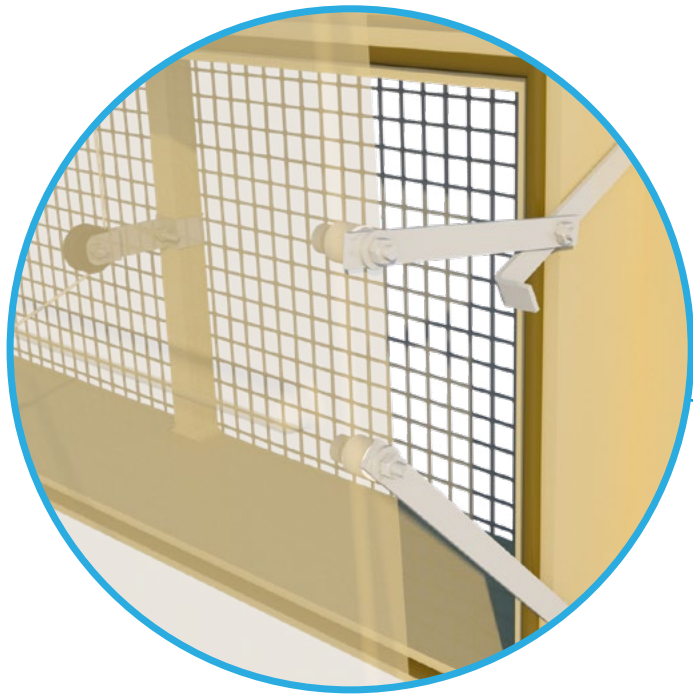

TPI-205 (Including TPI 621)

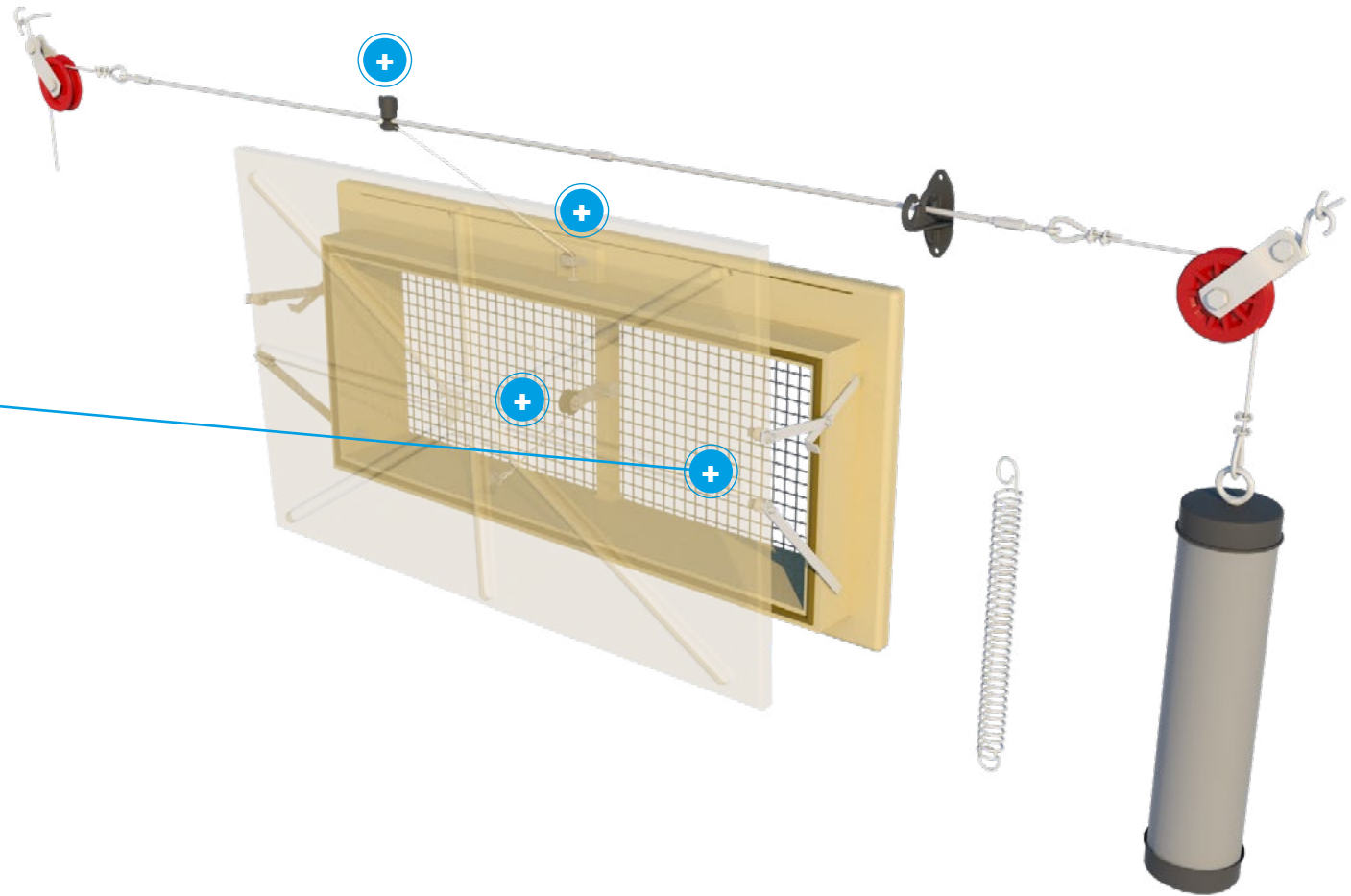

[INFO](#)

[DATASHEET](#)

[ASSEMBLY](#)

[MOUNTING](#)

[WORKING](#)

[MAINTENANCE](#)



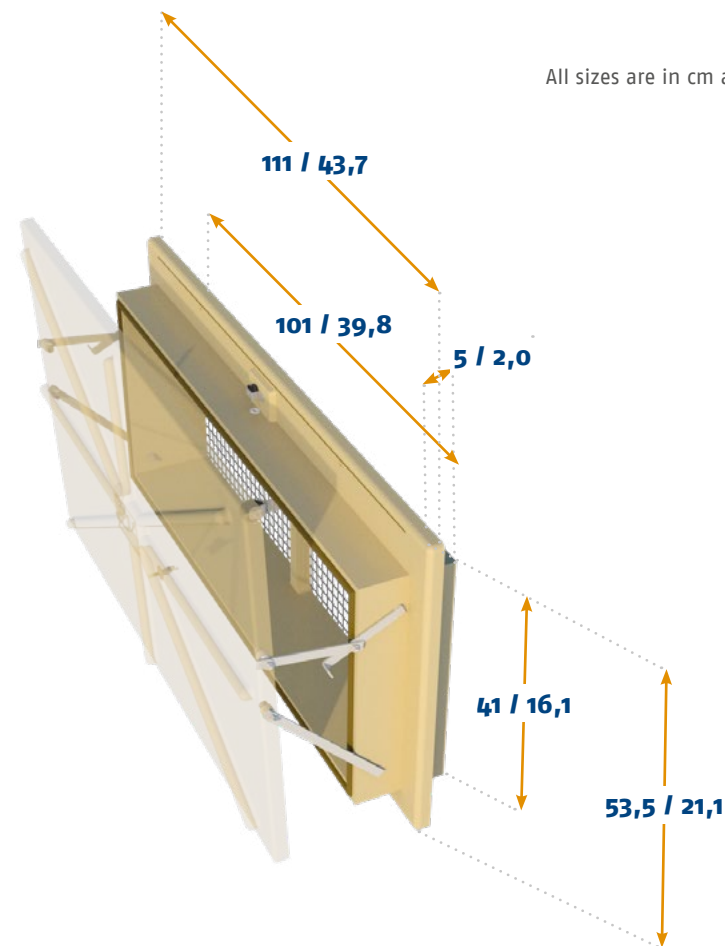
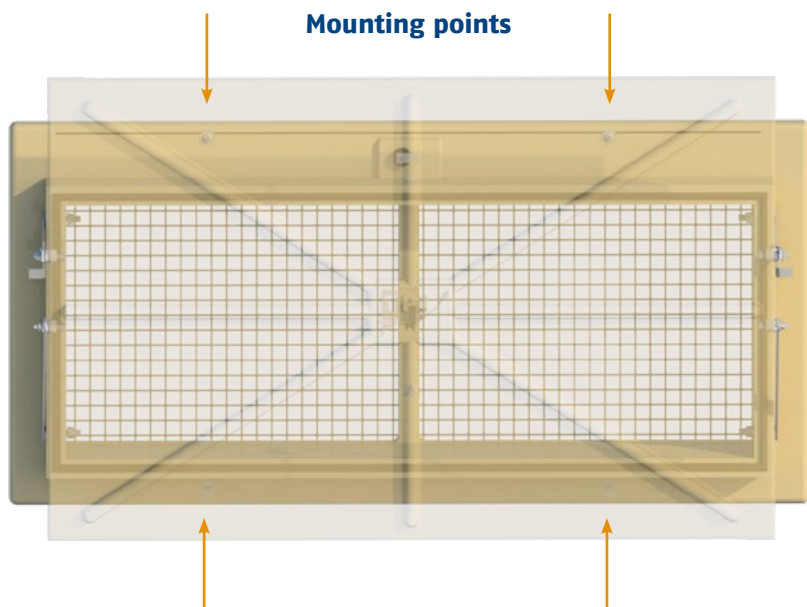

MOUNTING

Mounting type	Wall
Mounting hole size	103 cm / 40,6 inch x 43 cm / 13,8 inch

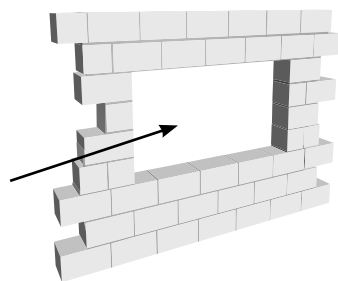

INFO

DATASHEET

ASSEMBLY

MOUNTING

WORKING

MAINTENANCE



AIR FLOW

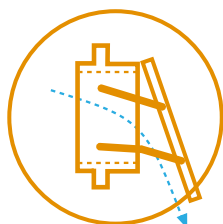
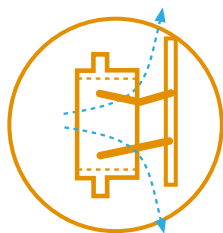
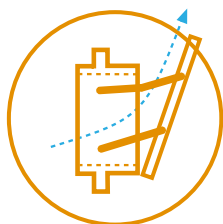

Indirect airflow

The Omnistep inlet works with a plate which guides the air in an upwards, downwards or evenly divided direction into the house. This plate prevents air to directly enter the cages or nest systems.

Working with end-weights or springs

We offer two products which can be used to keep tension on the main cable. A PVC cylinder which can be filled with concrete or sand to act as end-weight, or a spring that holds tension on the cable.

Balanced set-up

When placing the motor winch or actuator we normally suggest to divide the inlets in two groups. It is preferable to place the winch or actuator in the middle to equally divide the forces on the main cable. (see ventilation concepts page for an example)

Use of closing catches

The closing catch on the inlet can be used to permanently close inlets for example during pre-heating. The closing catches can also be used to close certain inlets while continuing to use others. In that case the used inlets can be opened a bit further. In colder climates this can help to offer better resistance to freezing effects.

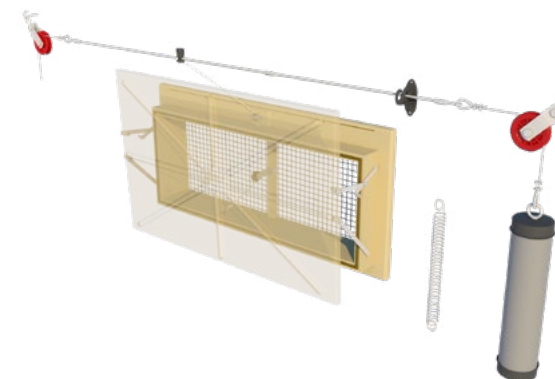

INFO

DATASHEET

ASSEMBLY

MOUNTING

WORKING

MAINTENANCE



VENTUM

The Ventum is developed to make our unique air inlet features and technologies available for American building and ventilation concepts. The dimensions of the Ventum are more universal making it easily usable in renovation projects where existing inlets need replacement. This inlet is suitable mostly for poultry houses since the curved inner valve helps to guide air downwards to the birds during maximum ventilation. The valve and frame of this inlet is equipped with wear resistant stripping all around to prevent air leakage and the curved inner corners of the frame help to optimize air intake. Our unique polyurethane formula and the use of air seals assures optimum insulation making the inlet ideal for extremely low temperatures.

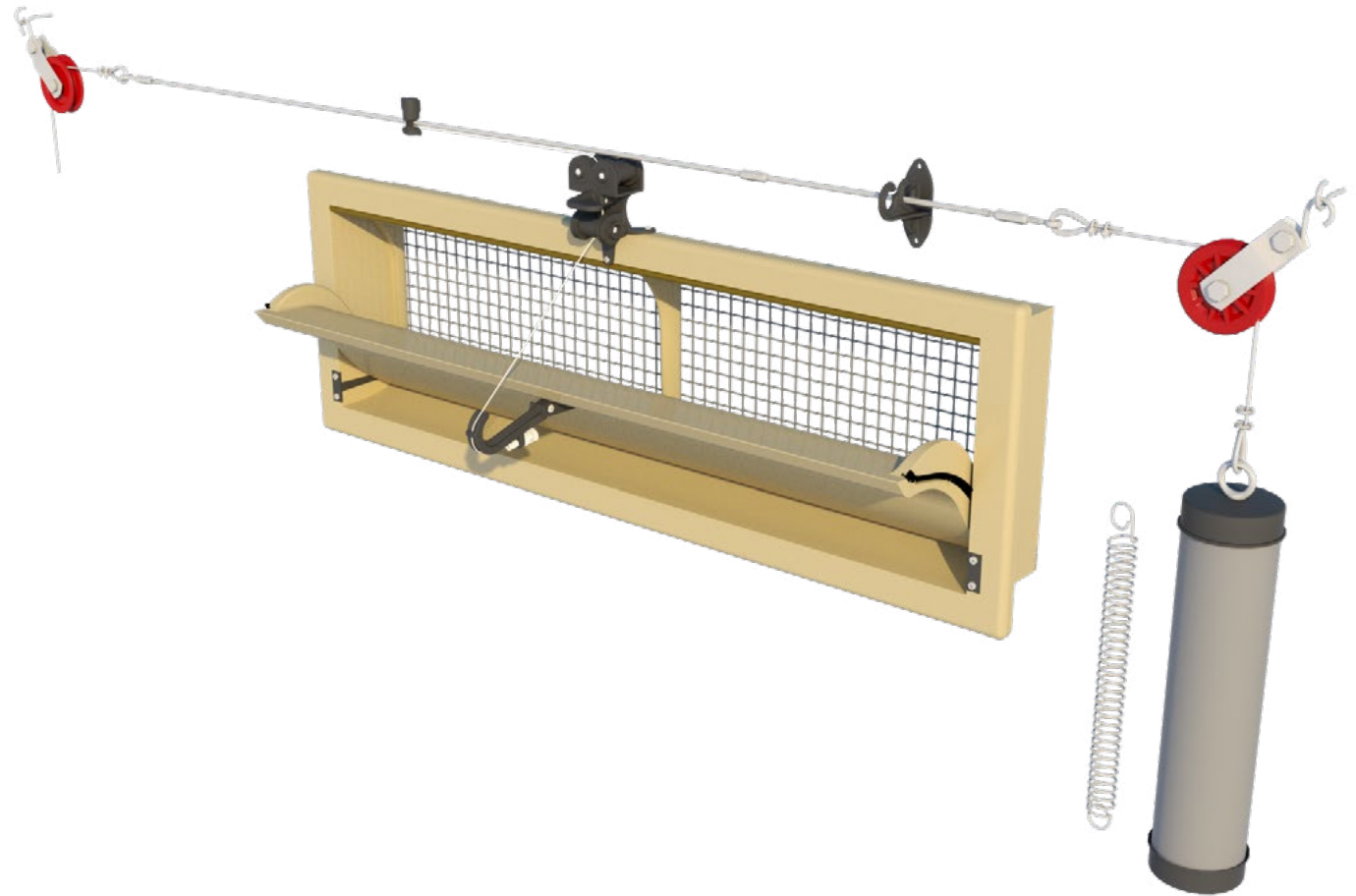

[INFO](#)

[DATASHEET](#)

[ASSEMBLY](#)

[MOUNTING](#)

[WORKING](#)

[MAINTENANCE](#)





VENTUM DATASHEET



CAPACITY

Model	m ³ /h @ 10 Pa	m ³ /h @ 20 Pa	m ³ /h @ 40 Pa
Ventum	3480	4900	6950
	cfm @ 0.05 inH ₂ O	cfm @ 0.1 inH ₂ O	cfm @ 0.15 inH ₂ O
	2290	3218	3950

INFORMATION

Run	47 cm / 18.5 inch
Force	3 kg / 29.4 Newton
Number / pallet (1,30 x 1,00 x 2,50m / 51 x 39 x 98inch)	38
Weight / per inlet	4,8 kg / 10.6 lbs
Volume / per box	19
Arm position	2

OPTIONAL ACCESSORIES

TPI-119	Wire mesh
TPI-204c	Connection set
TPI-423	Pulley Unit + Closing Catch

AIR FLOW

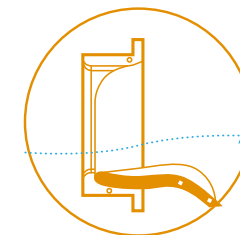
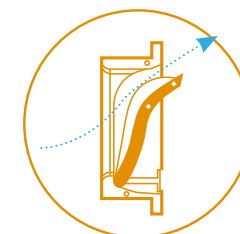

INFO

DATASHEET

ASSEMBLY

MOUNTING

WORKING

MAINTENANCE





TPI-621

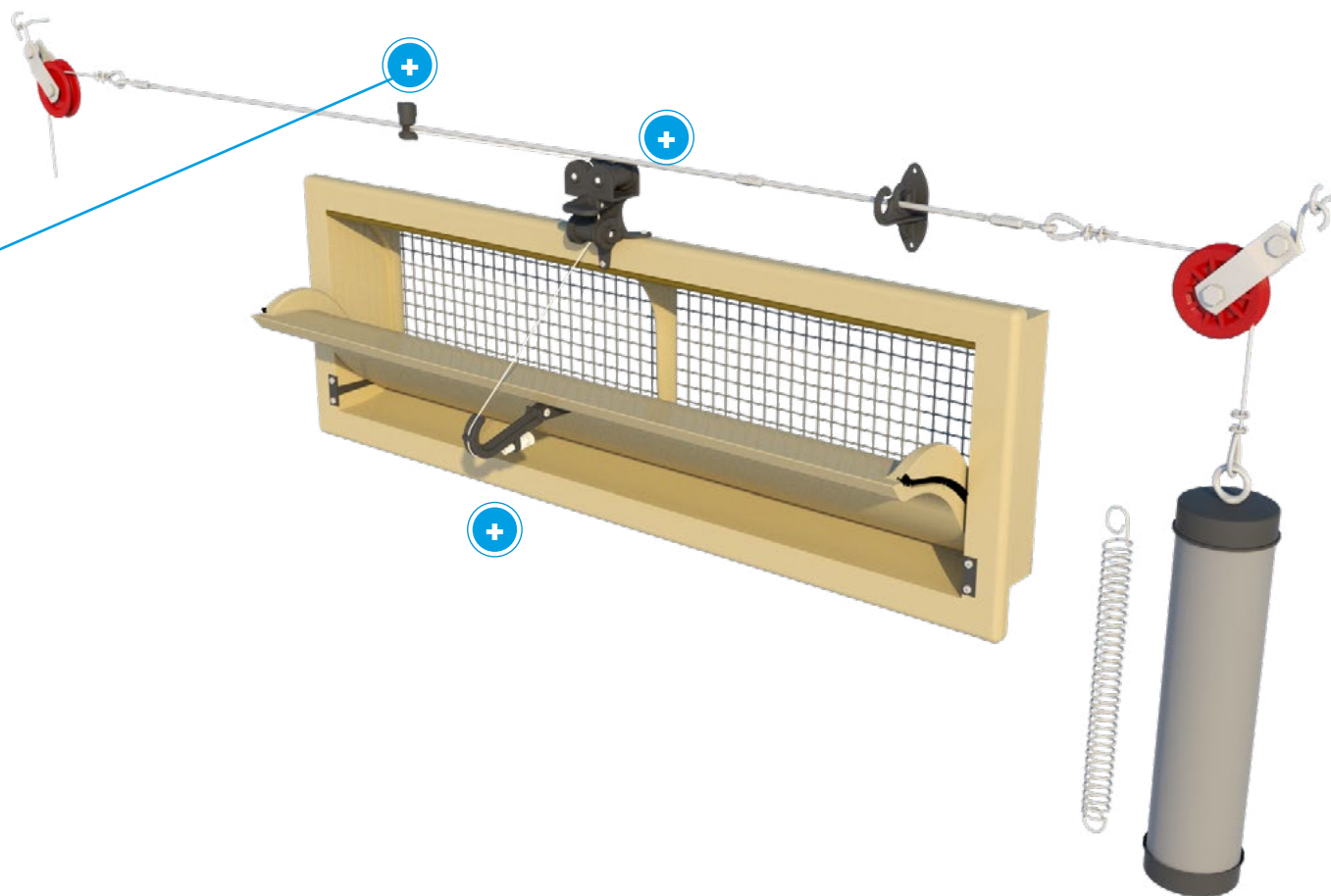

INFO

DATASHEET

ASSEMBLY

MOUNTING

WORKING

MAINTENANCE



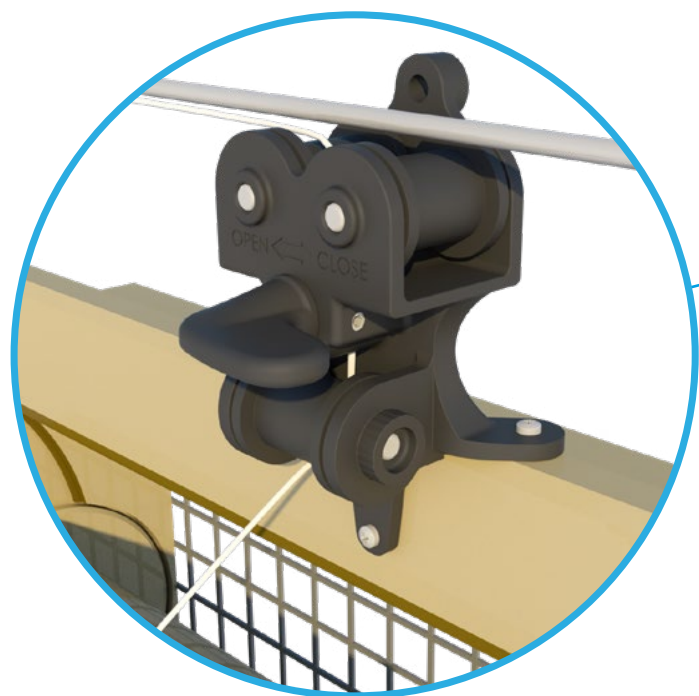

TPI-423

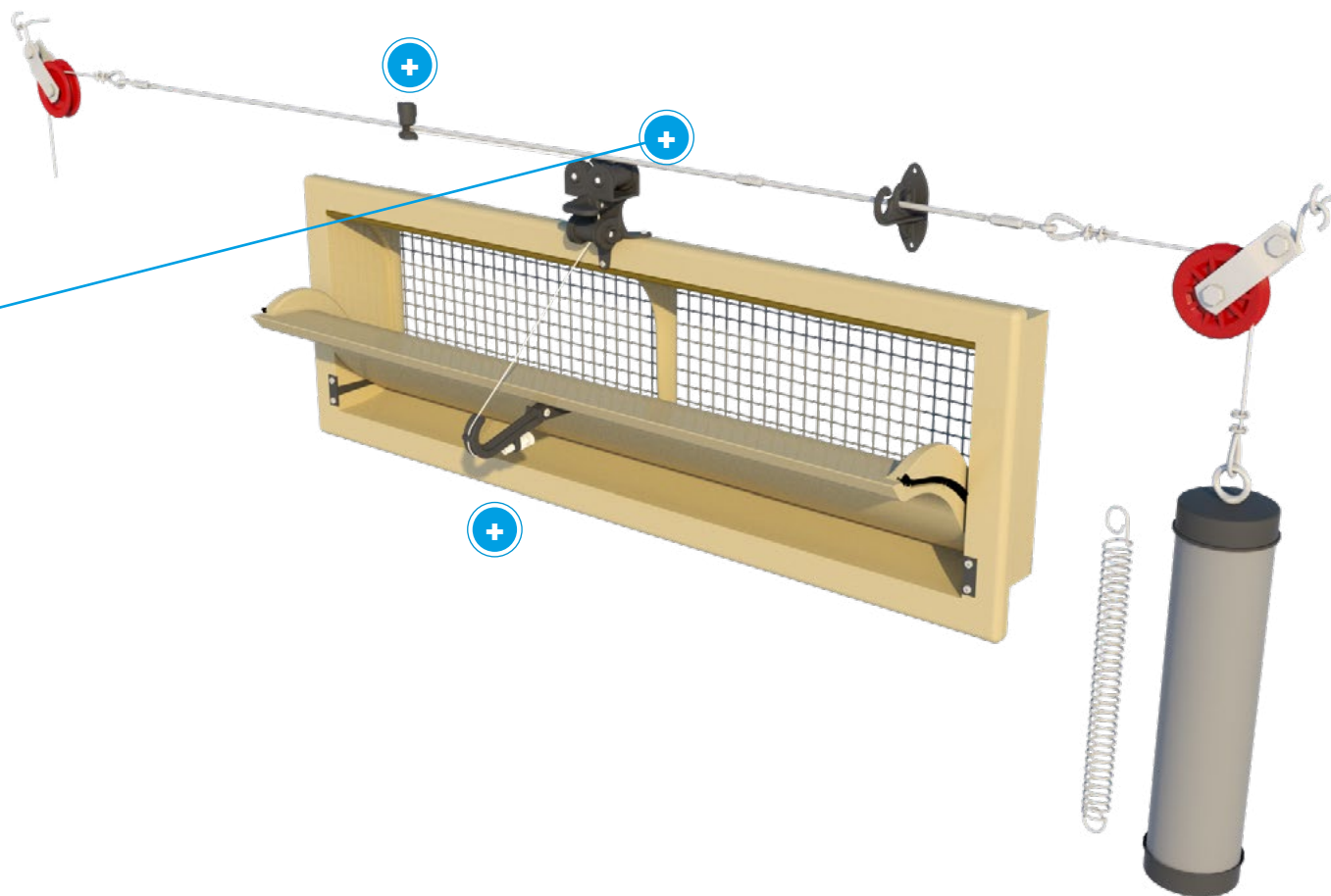

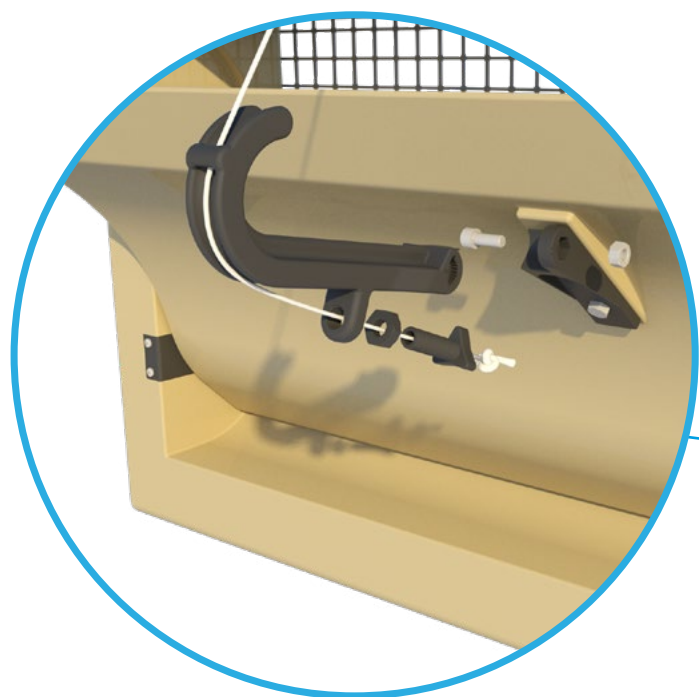

Arm angle position : 2

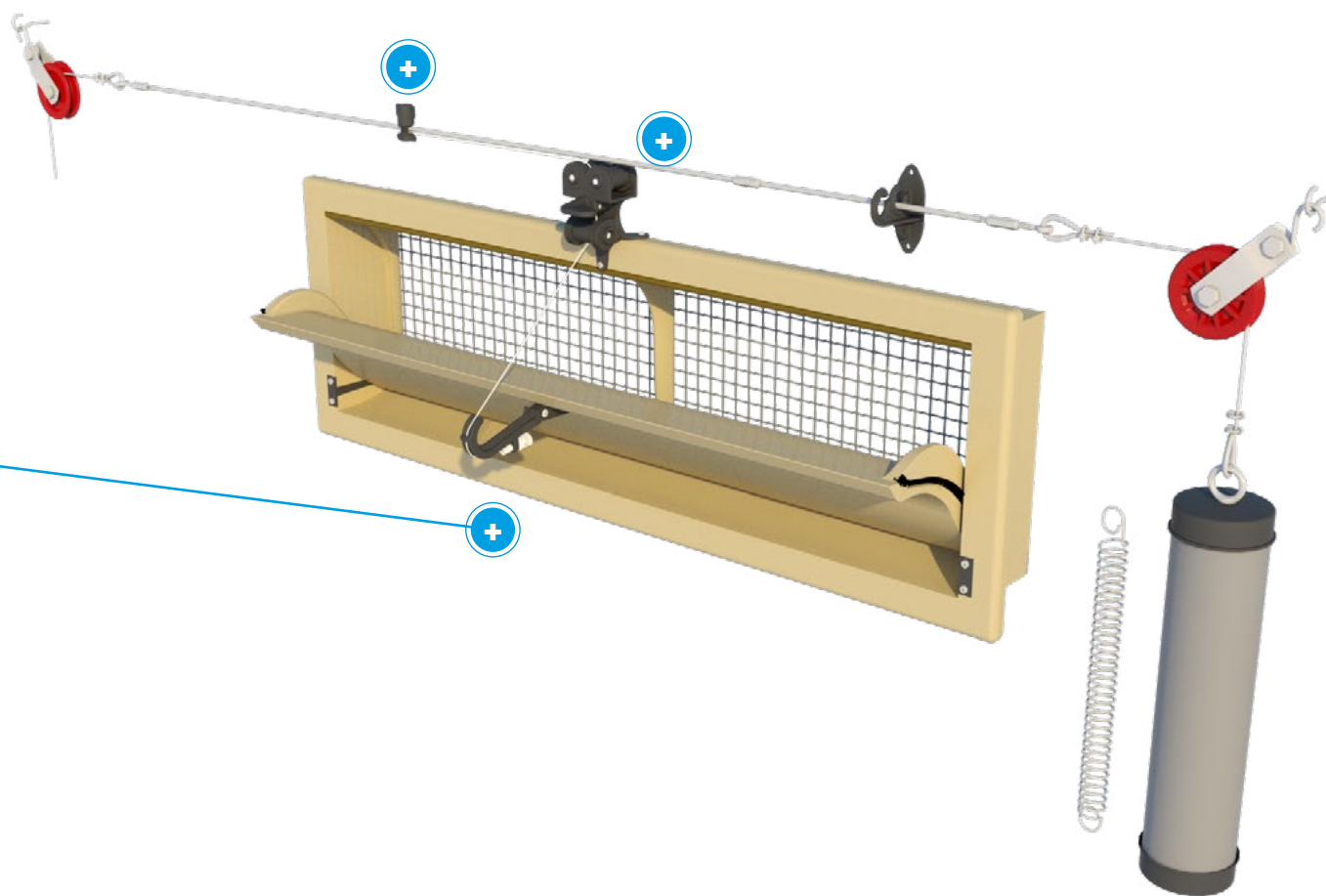

Mounting points

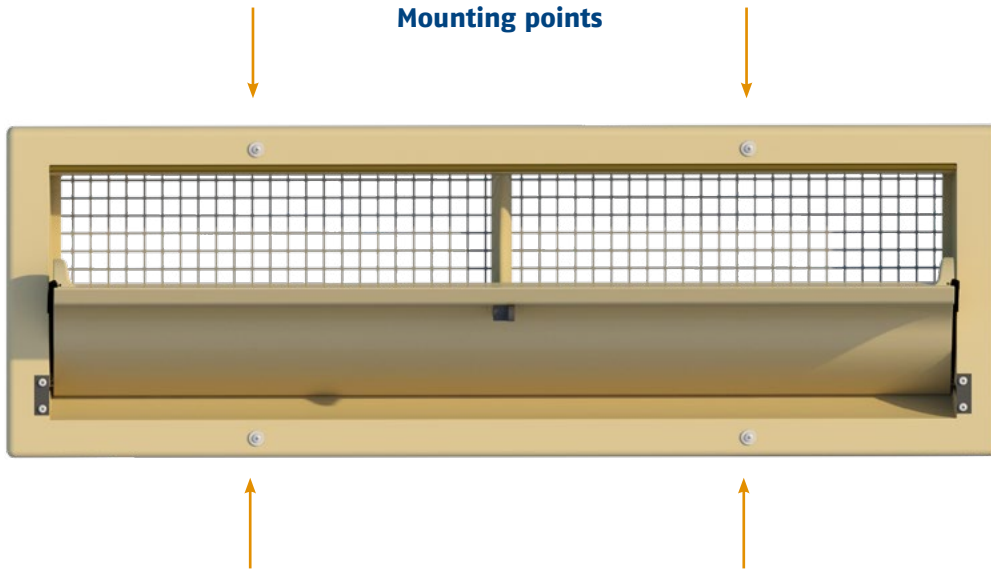

All sizes are in cm and inches

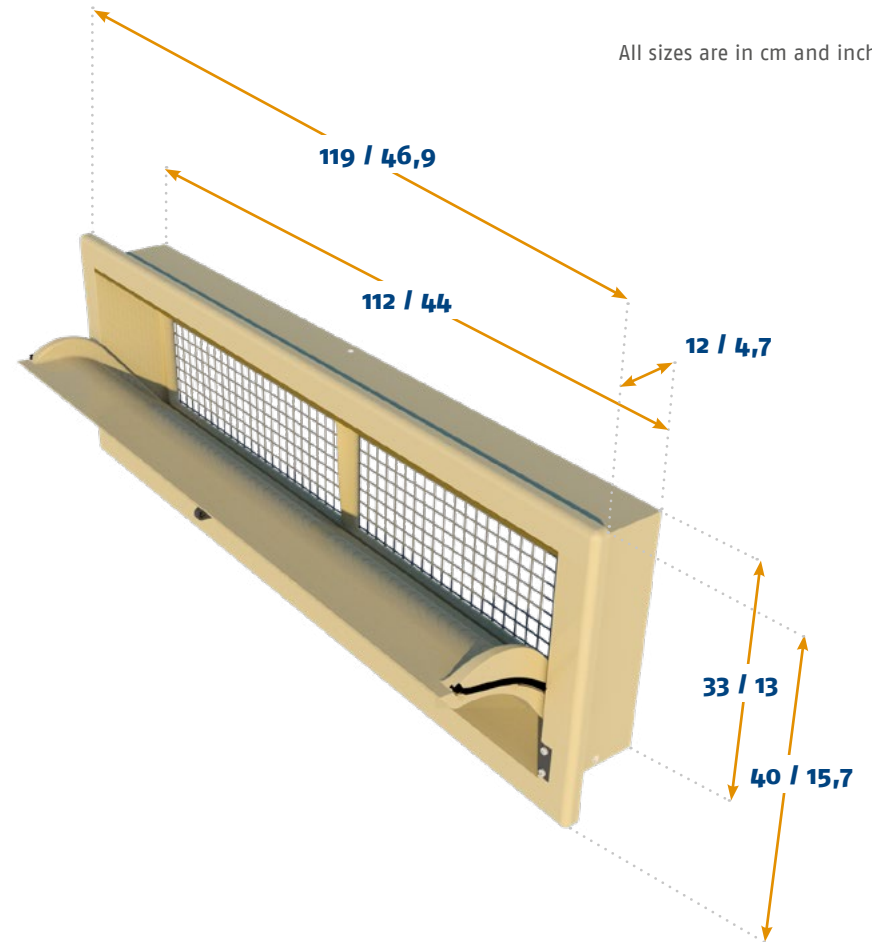

MOUNTING

Mounting type	Wall
Mounting hole size	114 cm / 45,7 inch x 35 cm / 13,8 inch

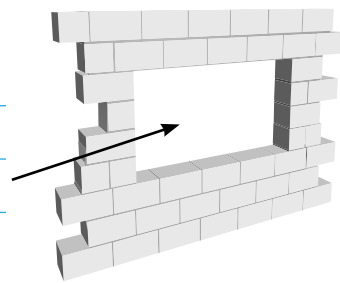

INFO

DATASHEET

ASSEMBLY

MOUNTING

WORKING

MAINTENANCE



AIR FLOW

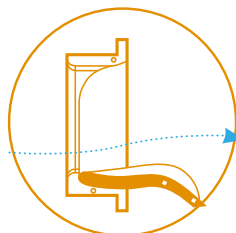
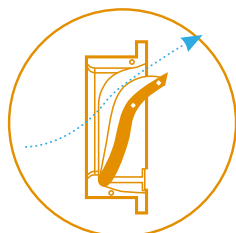

Opening and closing of inlets

Our standard inlets are spring-operated which means that without force on the main cable they will open automatically. The air inlets are connected to a main cable which can be pulled by a motor winch or actuator. In a normal situation, when pulling on the main cable the inlets are closing. The spring or end weight at the other end of the main cable makes sure the main cable is held straight and in place.

Self-closing inlets and delayed opening

A major part of our program can also be produced as a self-closing air inlet. In this scenario the opening and closing works the opposite way. The hanging pulleys have to be installed on the bottom flange and the central plastic control arm needs to guide the nylon cord downwards. The main cable has to be mounted underneath the inlets. With this set-up a system of delayed opening can be made, meaning that by adjusting the angle of the central control arm you can determine how early or late an inlet opens compared to another on the same line.

Making adjustments

By using the nylon bolt and nut small adjustments can be made to make sure all inlets are closing and opening correctly. The nylon cable clamp and cord can also be used to make small adjustments.

Working with springs or end-weights

At the opposite end on the main cable of where the motor winch or actuator is located there are two options to choose from: an end-weight which can be filled with concrete or sand, or a spring that holds tension on the cable.

Balanced set-up

When placing the motor winch or actuator we normally suggest to divide the inlets in two groups. It is often preferable to place the motor winch or actuator in the middle to equally split the forces that are exerted upon the inlets and winch.

Use of closing catches

The closing catch on the inlet can be used to permanently close inlets for example during pre-heating. The closing catches can also be used to close certain inlets while continuing to use others therefore offering the opportunity to open the inlets which are in use a bit further. In colder climates this can help to offer better resistance to freezing effects.

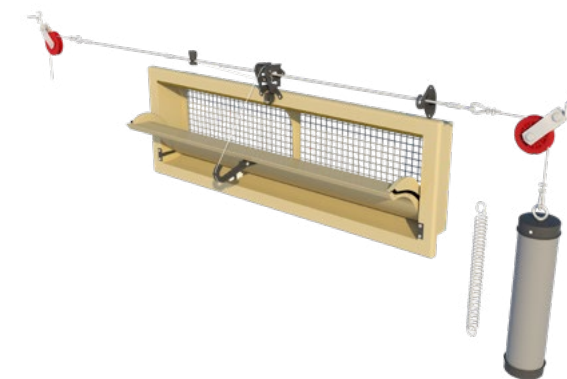

INFO

DATASHEET

ASSEMBLY

MOUNTING

WORKING

MAINTENANCE



VENTUM tunnel

The Ventum is developed to make our unique air inlet features and technologies available for American building and ventilation concepts. The dimensions of the Ventum are more universal making it easily usable in renovation projects where existing inlets need replacement. This inlet is suitable mostly for poultry houses since the curved inner valve helps to guide air downwards to the birds during maximum ventilation. The valve and frame of this inlet is equipped with wear resistant stripping all around to prevent air leakage and the curved inner corners of the frame help to optimize air intake. Our unique polyurethane formula and the use of air seals assures optimum insulation making the inlet ideal for extremely low temperatures.

[INFO](#)[DATASHEET](#)[ASSEMBLY](#)[MOUNTING](#)[WORKING](#)[MAINTENANCE](#)



VENTUM-2 DATASHEET



CAPACITY

Model	m ³ /h @ 10 Pa	m ³ /h @ 20 Pa	m ³ /h @ 40 Pa
Ventum-2:	6960	9800	13.900
	cfm @ 0.05 inH ₂ O	cfm @ 0.1 inH ₂ O	cfm @ 0.15 inH ₂ O
	4580	6436	7900

INFORMATION

Run	40 cm / 15.7 Inch
Force	6 kg / 59 Newton
Number / pallet (1,30 x 1,00 x 2,50m / 51 x 39 x 98inch)	19
Weight / per tunnel	9,6kg / 21.2 lbs
Arm position	3+

OPTIONAL ACCESSORIES

TPI-119 (*2)	Wire mesh synthetic
TPI-222	Connection set
TPI-308 (*4)	Closing catch

AIR FLOW

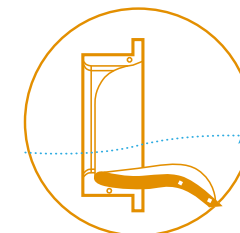
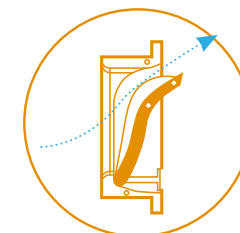

INFO

DATASHEET

ASSEMBLY

MOUNTING

WORKING

MAINTENANCE



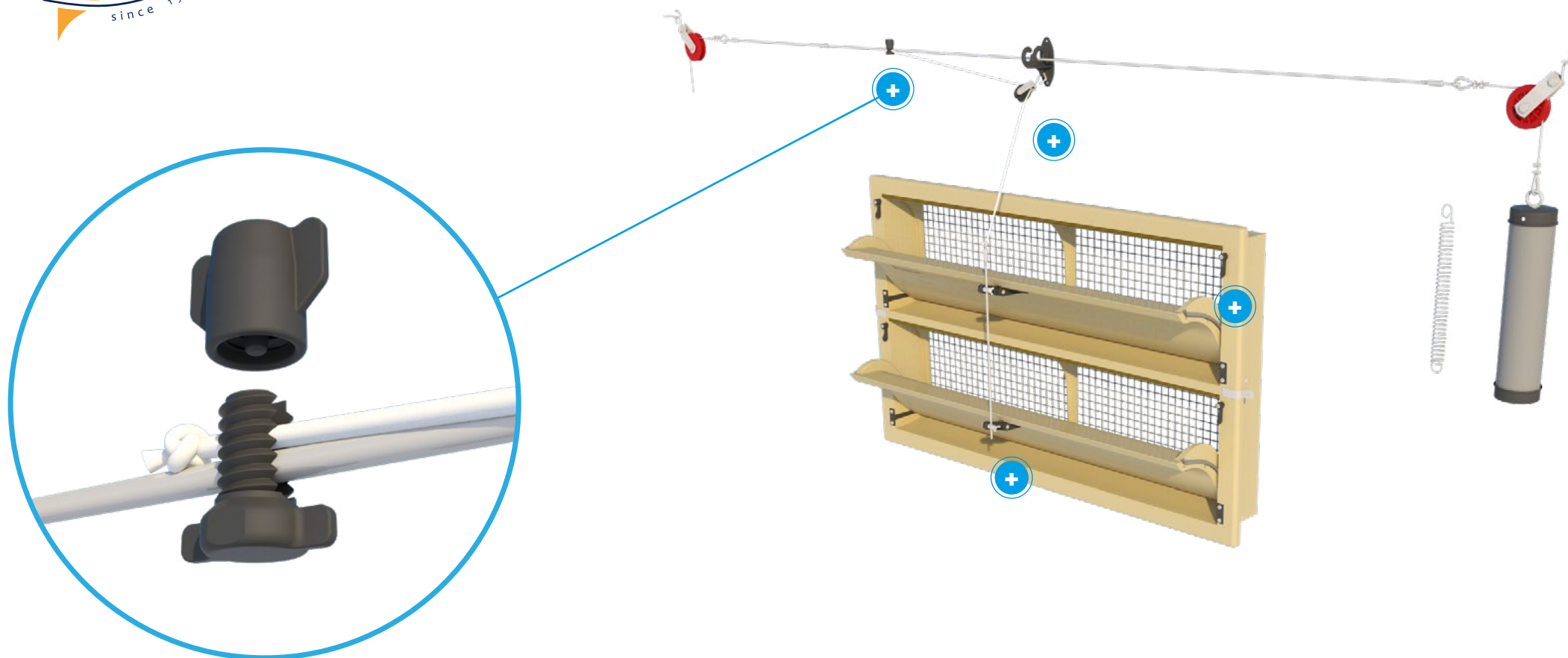

TPI-204C

INFO

DATASHEET

ASSEMBLY

MOUNTING

WORKING

MAINTENANCE



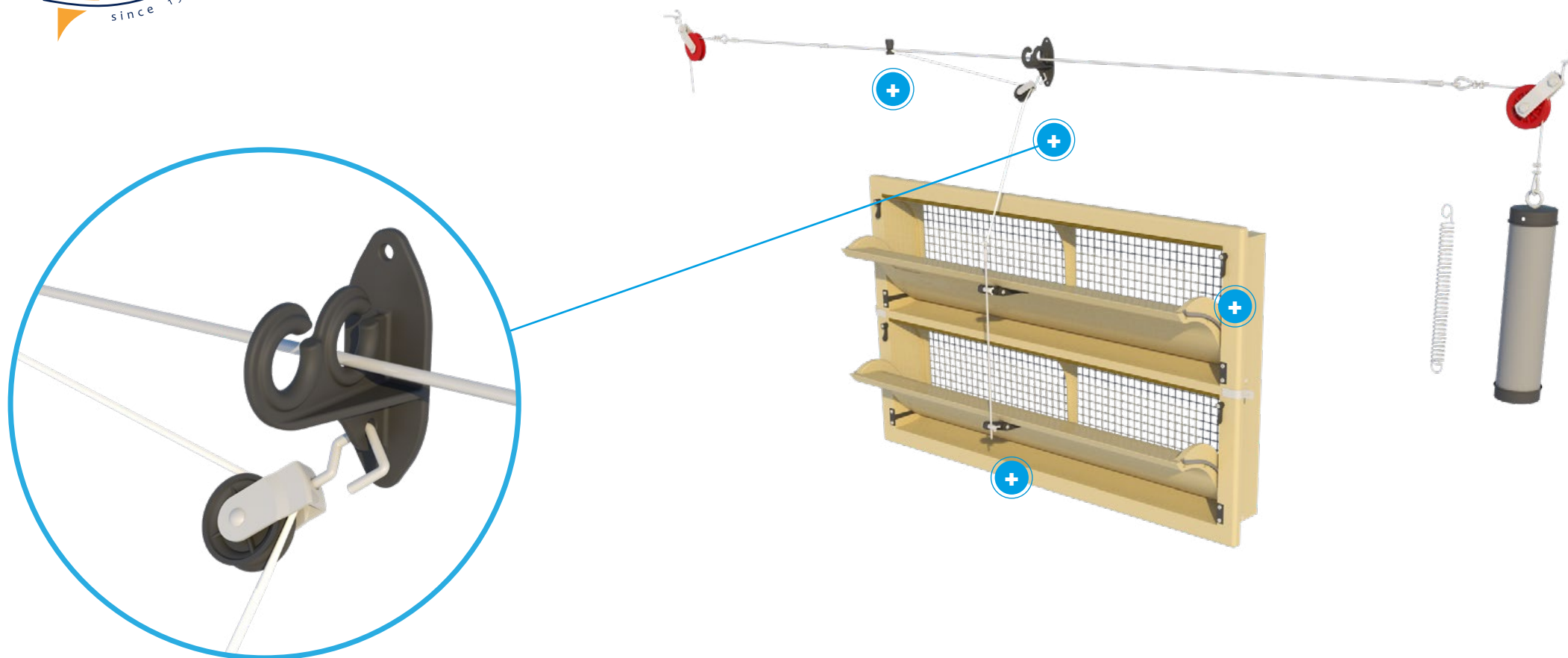

TPI-421

[INFO](#)

[DATASHEET](#)

[ASSEMBLY](#)

[MOUNTING](#)

[WORKING](#)

[MAINTENANCE](#)



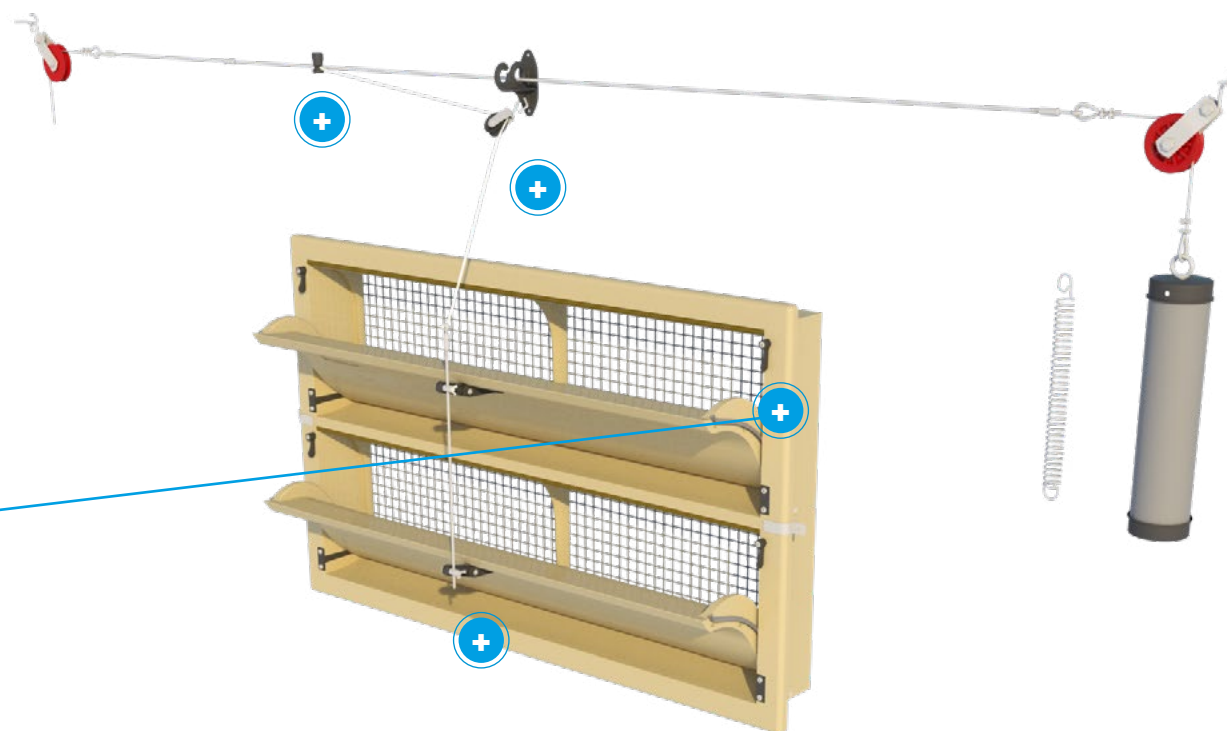
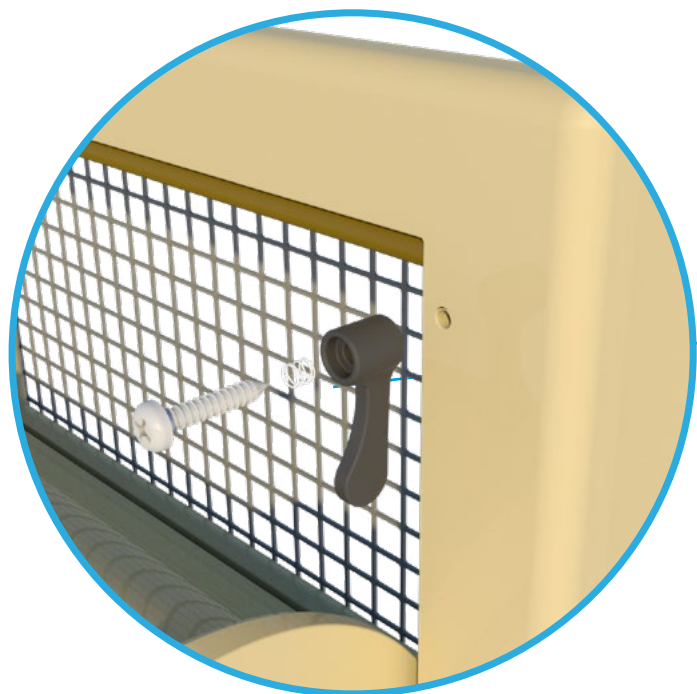

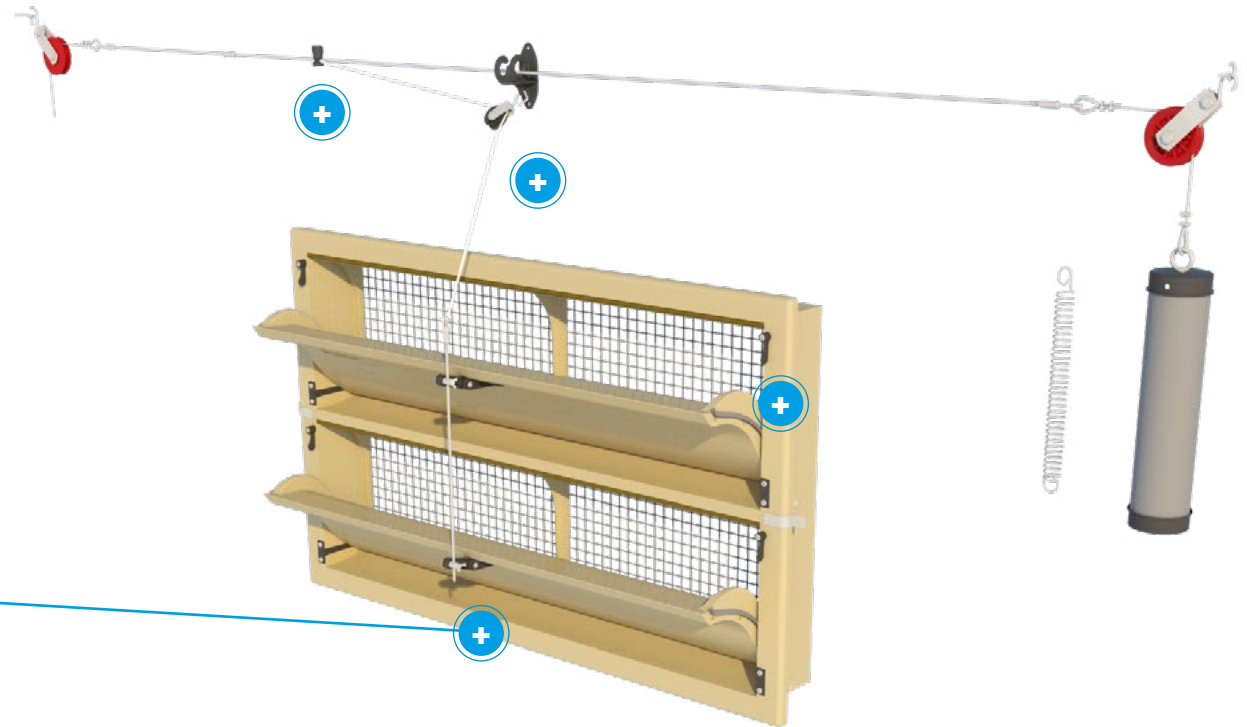

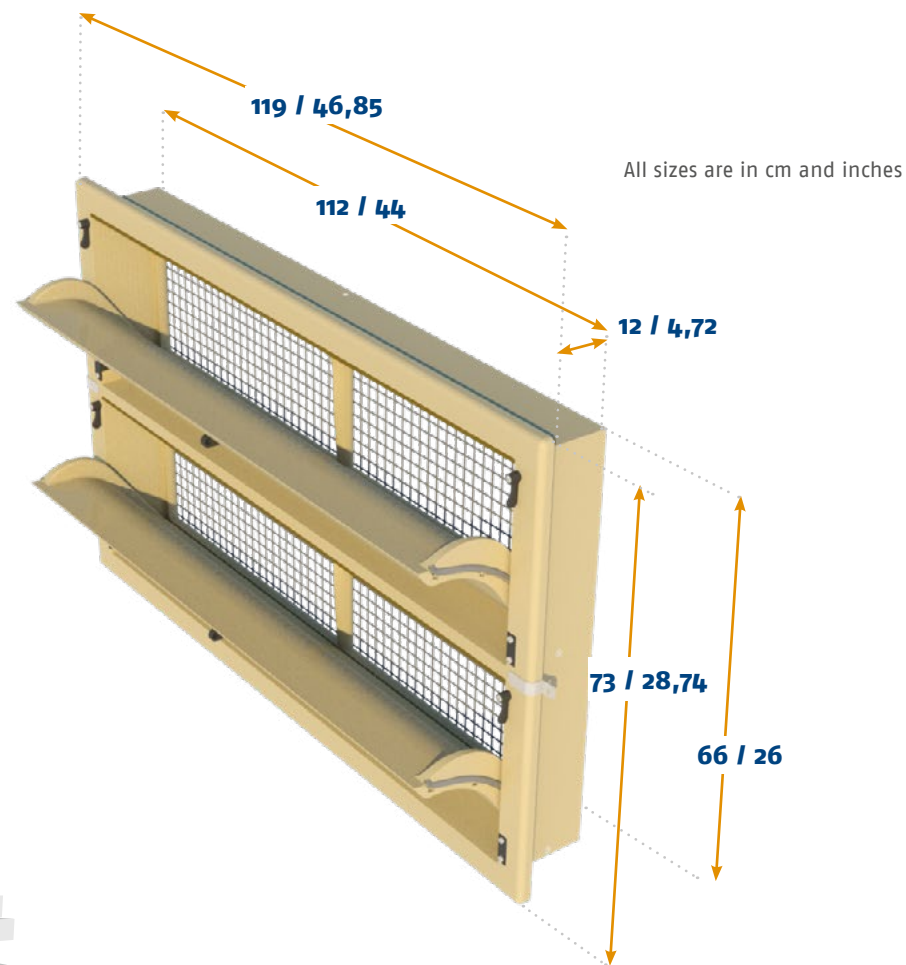
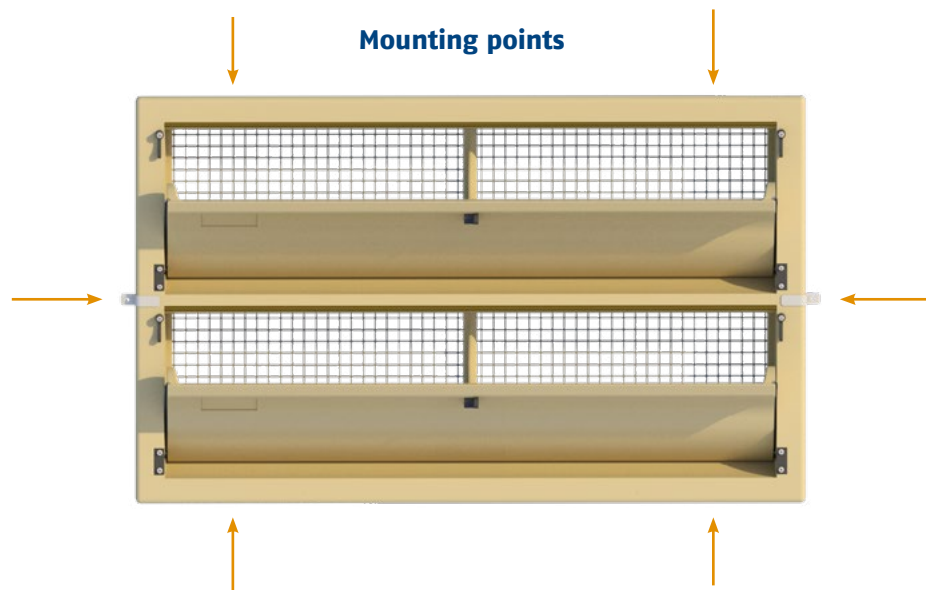

MOUNTING

Mounting type

Wall

Mounting hole size

W 114 cm / 44,88 inch x H 68 cm / 26,77 inch

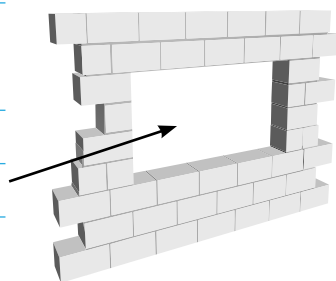

[INFO](#)

[DATASHEET](#)

[ASSEMBLY](#)

[MOUNTING](#)

[WORKING](#)

[MAINTENANCE](#)



AIR FLOW

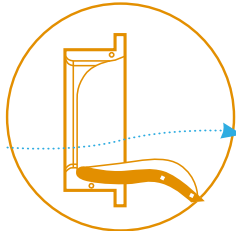
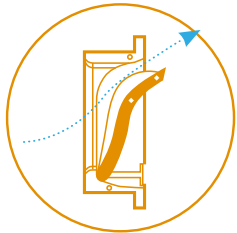

Bottom hinged inlet

Ventum inlets are bottom hinged, therefore also these modular tunnel units are bottom hinged. This means that at an early opening stage air does not flow underneath the inner flaps towards the animals. Instead air is guided upwards into the house.

Curved inner flap

This inlet is equipped with a curved inner flap. Curved flaps guide the air upwards during minimum ventilation, but also downwards after a certain point of opening. This is ideal for houses where air should be directed directly towards or over the animals during maximum ventilation.

Working with end-weights or springs

We offer two products which can be used to keep tension on the main cable. A PVC cylinder which can be filled with concrete or sand to act as end-weight, or a spring that holds tension on the cable.

Balanced set-up

When placing the motor winch or actuator we normally suggest to divide the inlets in two groups. It is preferable to place the winch or actuator in the middle to equally divide the forces on the main cable.

(see ventilation concepts page for an example)

Use of closing catches

The closing catch on the inlet can be used to permanently close inlets for example during pre-heating. The closing catches can also be used to close certain inlets while continuing to use others. In that case the used inlets can be opened a bit further. In colder climates this can help to offer better resistance to freezing effects.



INFO

DATASHEET

ASSEMBLY

MOUNTING

WORKING

MAINTENANCE



VENTUM tunnel

The Ventum is developed to make our unique air inlet features and technologies available for American building and ventilation concepts. The dimensions of the Ventum are more universal making it easily usable in renovation projects where existing inlets need replacement. This inlet is suitable mostly for poultry houses since the curved inner valve helps to guide air downwards to the birds during maximum ventilation. The valve and frame of this inlet is equipped with wear resistant stripping all around to prevent air leakage and the curved inner corners of the frame help to optimize air intake. Our unique polyurethane formula and the use of air seals assures optimum insulation making the inlet ideal for extremely low temperatures.



INFO

DATASHEET

ASSEMBLY

MOUNTING

WORKING

MAINTENANCE





VENTUM-3 DATASHEET



CAPACITY

Model	m ³ /h @ 10 Pa	m ³ /h @ 20 Pa	m ³ /h @ 40 Pa
Ventum-3:	10.440	14.700	20.850
	cfm @ 0.05 inH ₂ O	cfm @ 0.1 inH ₂ O	cfm @ 0.15 inH ₂ O
	6870	9654	11850

INFORMATION

Run	40 cm / 15.7 Inch
Force	9 kg / 88 Newton
Number / pallet (1,30 x 1,00 x 2,50m / 51 x 39 x 98inch)	12
Weight / per tunnel	14,4 kg / 31.7 lbs
Arm position	3+

OPTIONAL ACCESSORIES

TPI-119 (*3)	Wire mesh synthetic
TPI-223	Connection set
TPI-308 (*6)	Closing catch

AIR FLOW

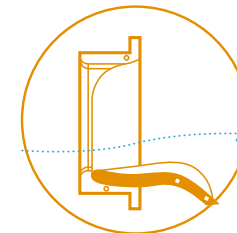
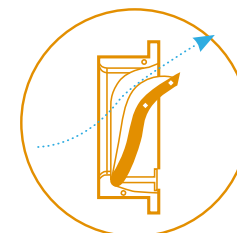

INFO

DATASHEET

ASSEMBLY

MOUNTING

WORKING

MAINTENANCE



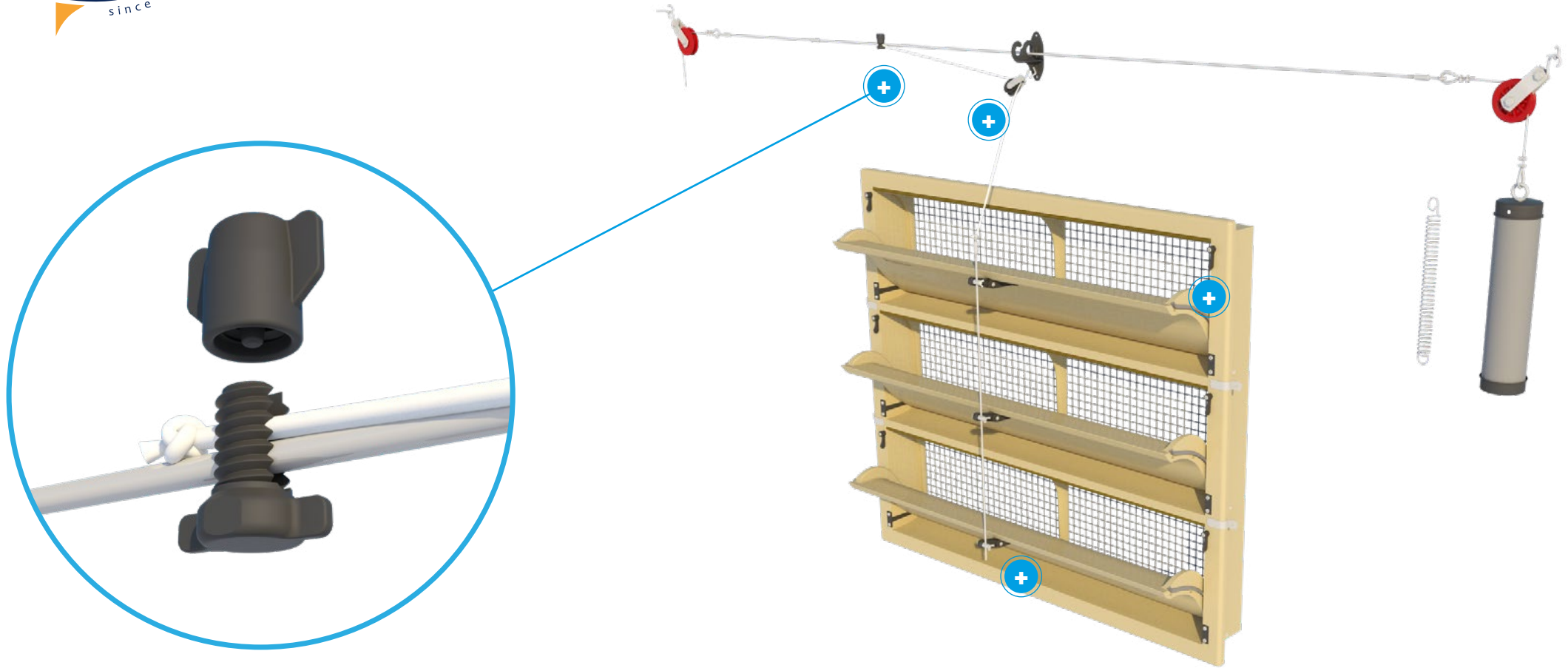

TPI-204C

INFO

DATASHEET

ASSEMBLY

MOUNTING

WORKING

MAINTENANCE



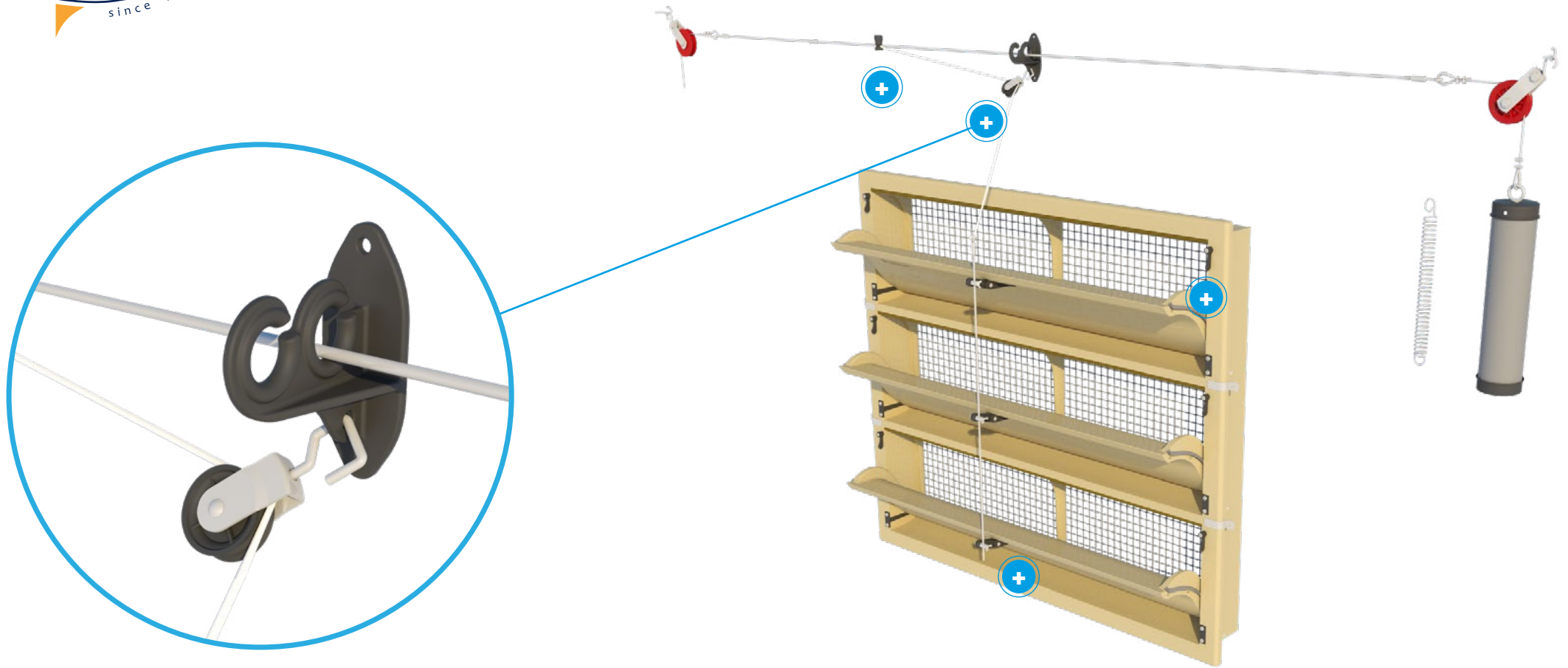

TPI-421

INFO

DATASHEET

ASSEMBLY

MOUNTING

WORKING

MAINTENANCE



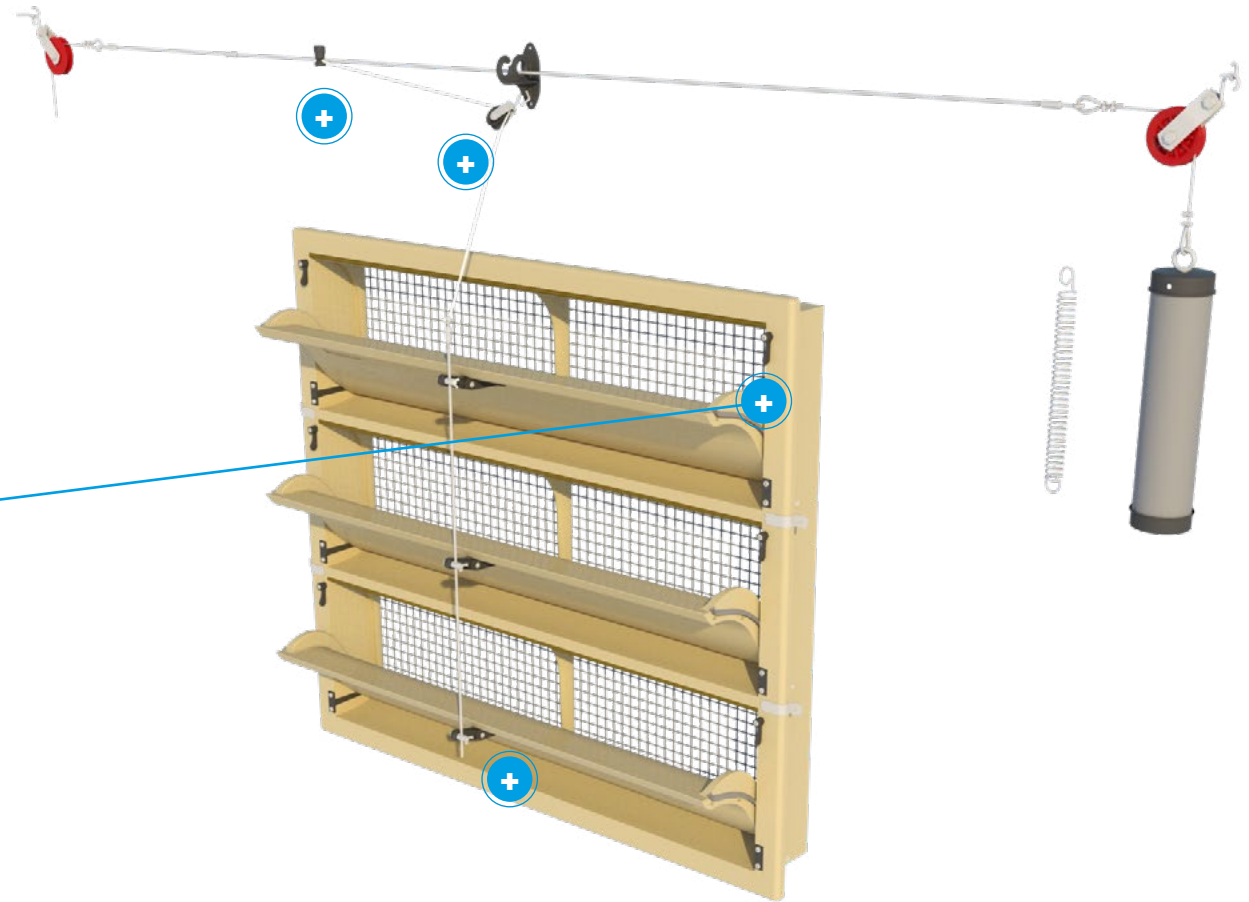
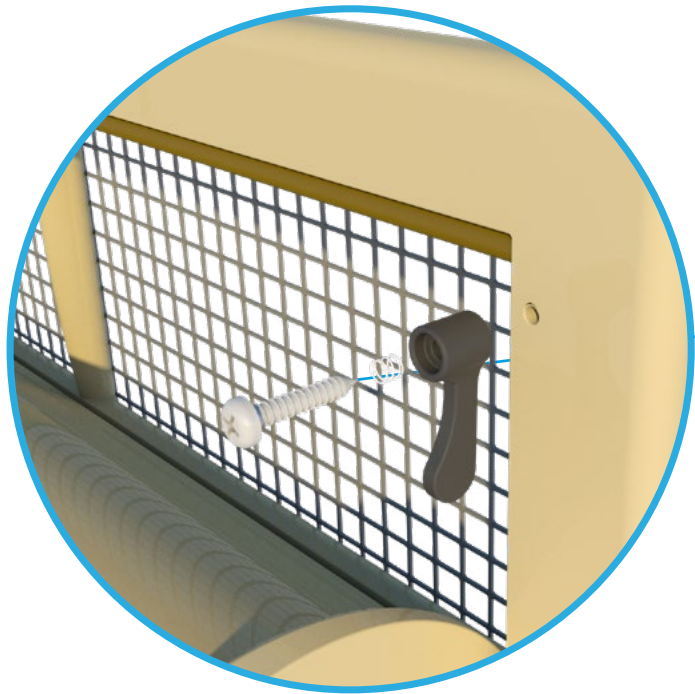

INFO

DATASHEET

ASSEMBLY

MOUNTING

WORKING

MAINTENANCE



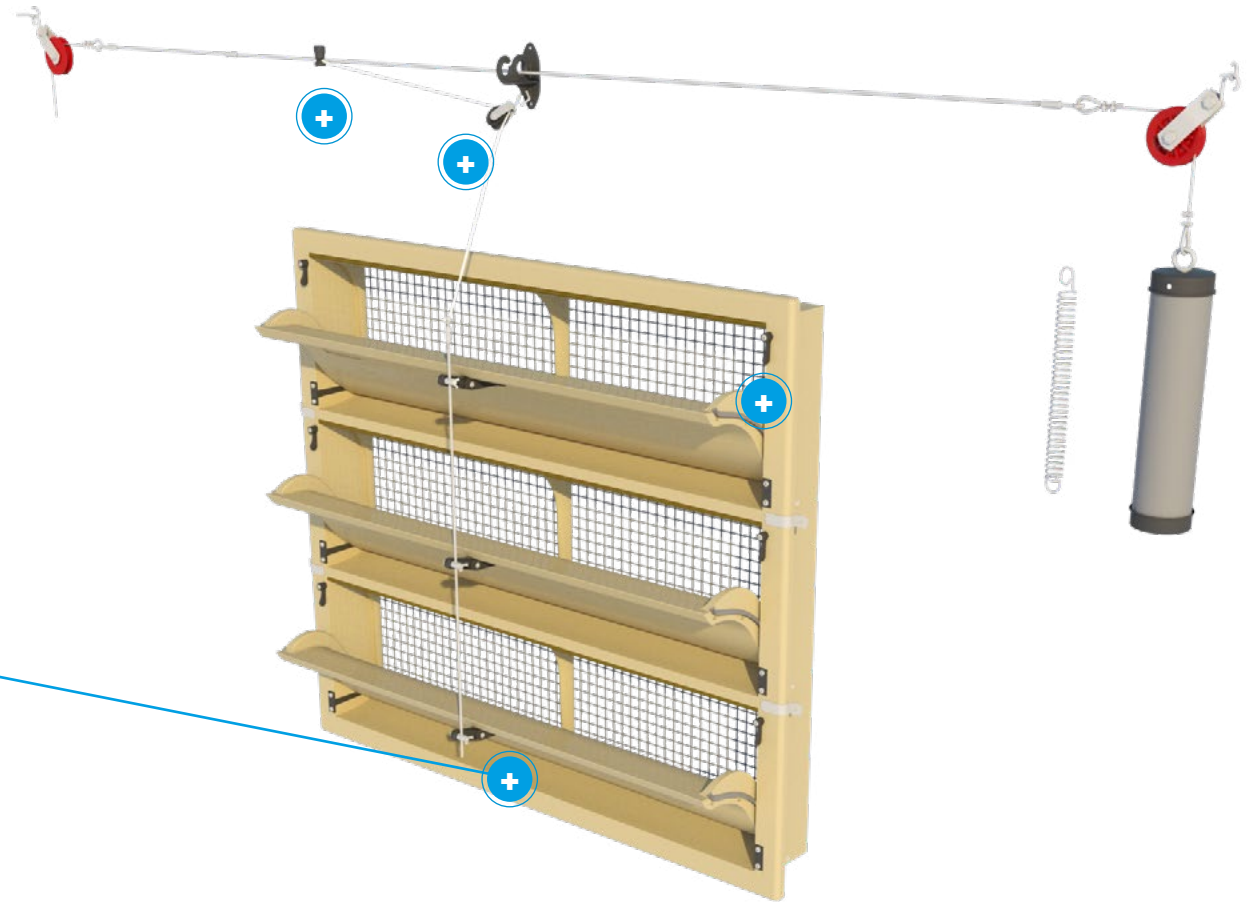

INFO

DATASHEET

ASSEMBLY

MOUNTING

WORKING

MAINTENANCE



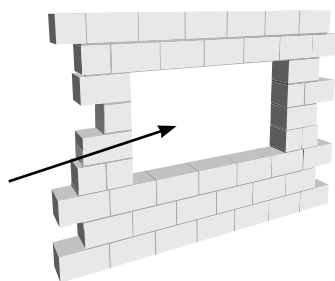
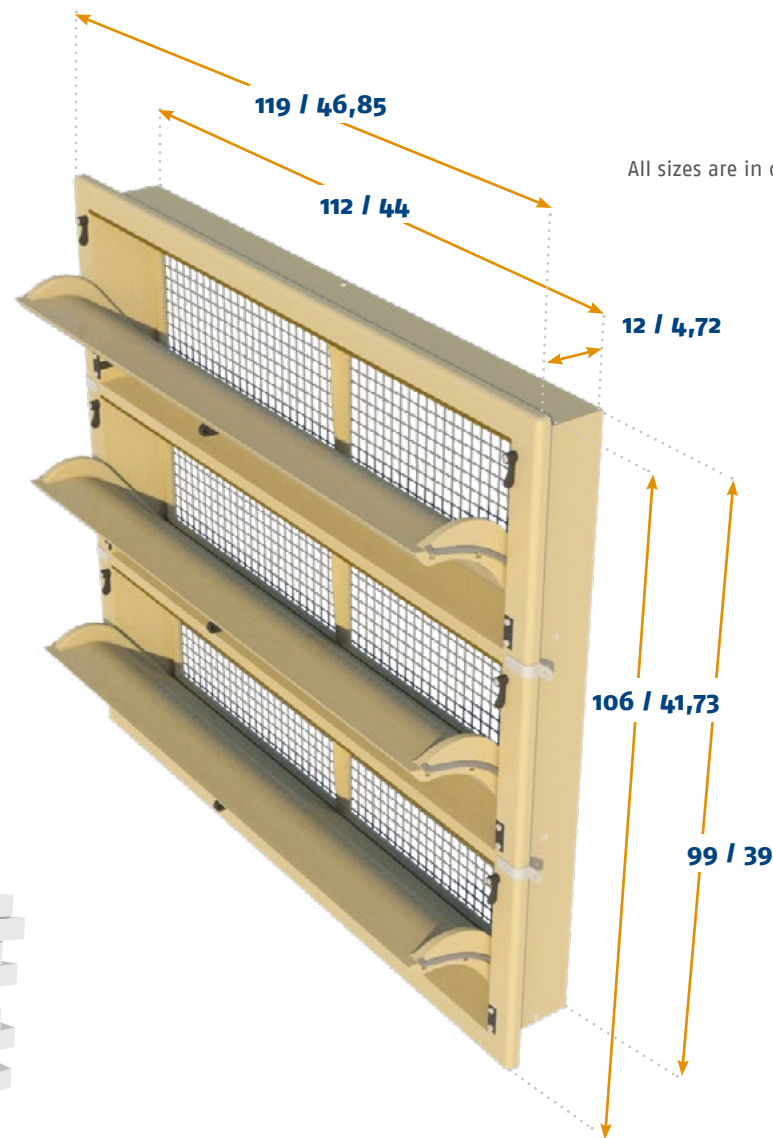
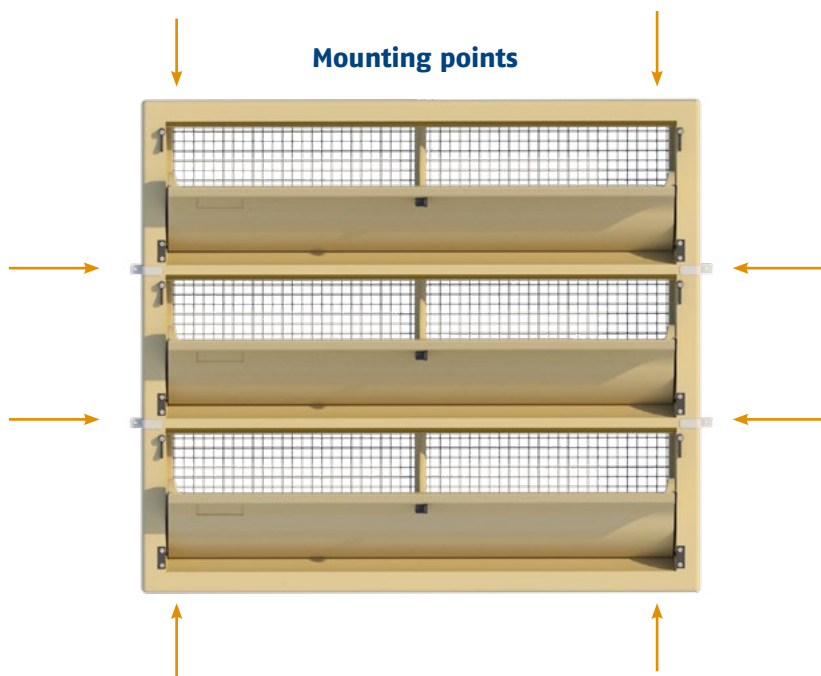

MOUNTING	
Mounting type	Wall
Mounting hole size	Ventum-3: W 114 cm / 44,88 inch x H 101 cm / 39,76 inch

AIR FLOW

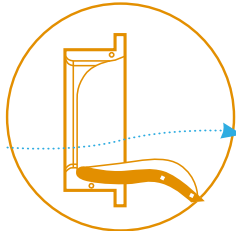
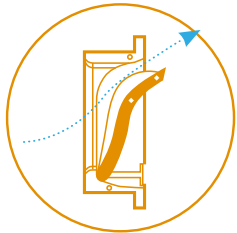

Bottom hinged inlet

Ventum inlets are bottom hinged, therefore also these modular tunnel units are bottom hinged. This means that at an early opening stage air does not flow underneath the inner flaps towards the animals. Instead air is guided upwards into the house.

Curved inner flap

This inlet is equipped with a curved inner flap. Curved flaps guide the air upwards during minimum ventilation, but also downwards after a certain point of opening. This is ideal for houses where air should be directed directly towards or over the animals during maximum ventilation.

Working with end-weights or springs

We offer two products which can be used to keep tension on the main cable. A PVC cylinder which can be filled with concrete or sand to act as end-weight, or a spring that holds tension on the cable.

Balanced set-up

When placing the motor winch or actuator we normally suggest to divide the inlets in two groups. It is preferable to place the winch or actuator in the middle to equally divide the forces on the main cable.

(see ventilation concepts page for an example)

Use of closing catches

The closing catch on the inlet can be used to permanently close inlets for example during pre-heating. The closing catches can also be used to close certain inlets while continuing to use others. In that case the used inlets can be opened a bit further. In colder climates this can help to offer better resistance to freezing effects.



VENTUM tunnel

The Ventum is developed to make our unique air inlet features and technologies available for American building and ventilation concepts. The dimensions of the Ventum are more universal making it easily usable in renovation projects where existing inlets need replacement. This inlet is suitable mostly for poultry houses since the curved inner valve helps to guide air downwards to the birds during maximum ventilation. The valve and frame of this inlet is equipped with wear resistant stripping all around to prevent air leakage and the curved inner corners of the frame help to optimize air intake. Our unique polyurethane formula and the use of air seals assures optimum insulation making the inlet ideal for extremely low temperatures.



INFO

DATASHEET

ASSEMBLY

MOUNTING

WORKING

MAINTENANCE





VENTUM-4 DATASHEET



CAPACITY

Model	m ³ /h @ 10 Pa	m ³ /h @ 20 Pa	m ³ /h @ 40 Pa
Ventum-4:	13.920	19.600	27.800
	cfm @ 0.05 inH ₂ O	cfm @ 0.1 inH ₂ O	cfm @ 0.15 inH ₂ O
	9160	12872	15801

INFORMATION

Run	40 cm / 15.7 Inch
Force	12 kg / 118 Newton
Number / pallet (1,30 x 1,00 x 2,50m / 51 x 39 x 98inch)	9
Weight / per tunnel	19,2kg / 42.3 lbs
Arm position	3+

OPTIONAL ACCESSORIES

TPI-119 (*4)	Wire Mesh synthetic
TPI-224	Connection set
TPI-308 (*8)	Closing catch

AIR FLOW

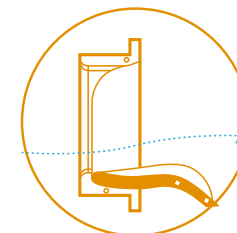
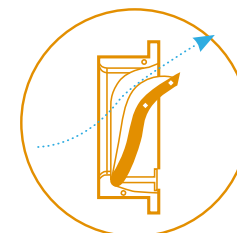

INFO

DATASHEET

ASSEMBLY

MOUNTING

WORKING

MAINTENANCE





VENTUM ASSEMBLY



TPI-204C

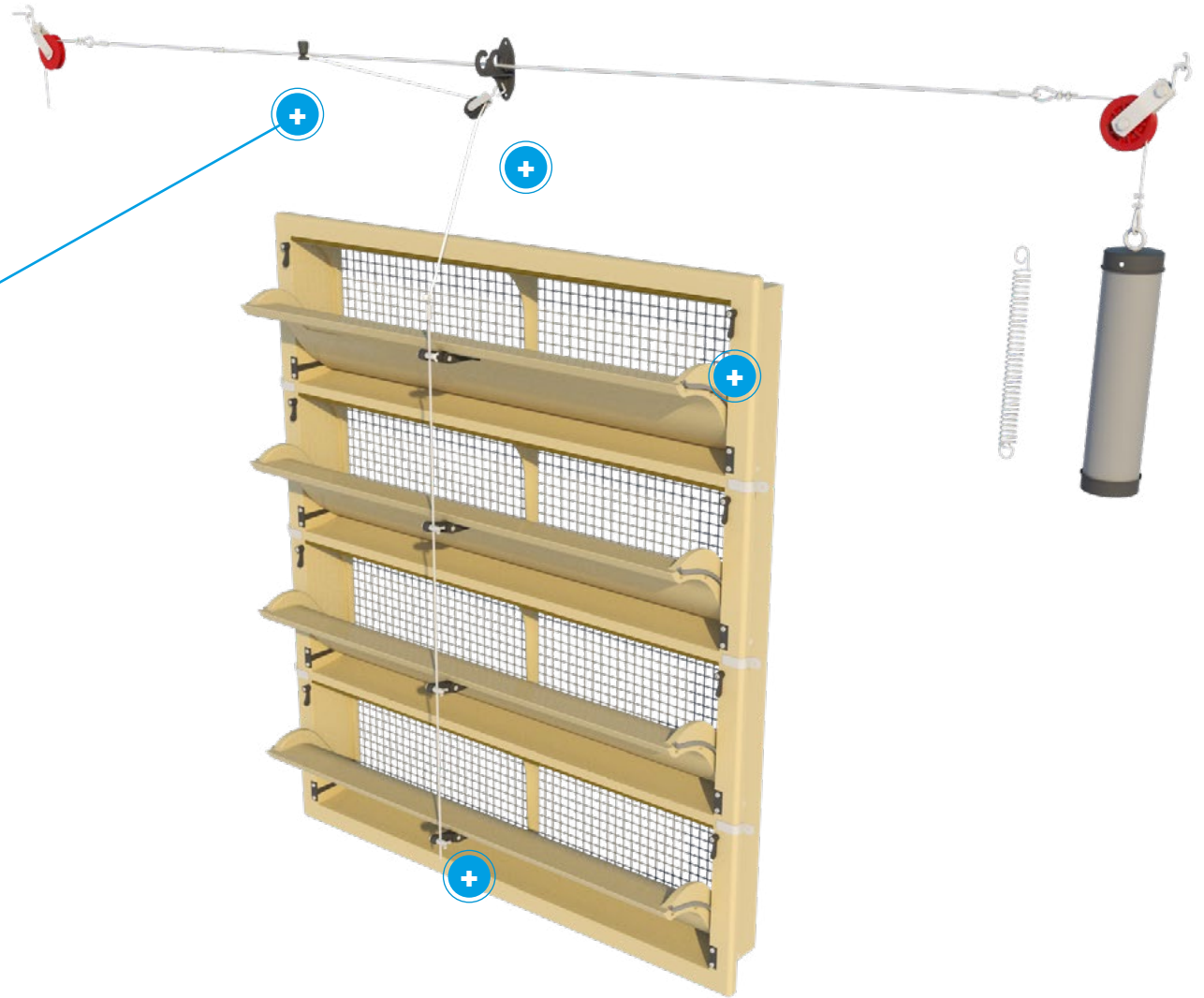

[INFO](#)

[DATASHEET](#)

[ASSEMBLY](#)

[MOUNTING](#)

[WORKING](#)

[MAINTENANCE](#)



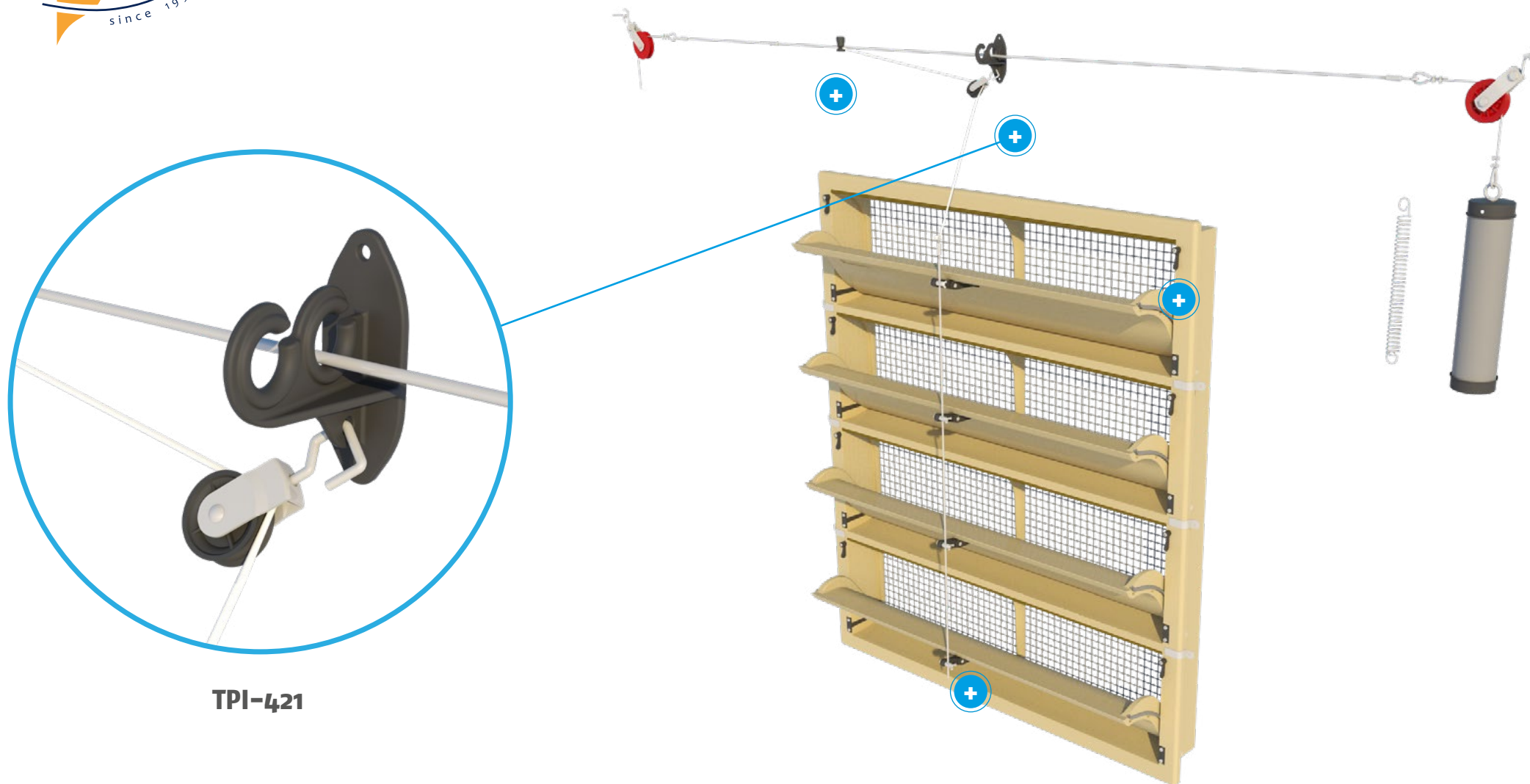

TPI-421

INFO

DATASHEET

ASSEMBLY

MOUNTING

WORKING

MAINTENANCE



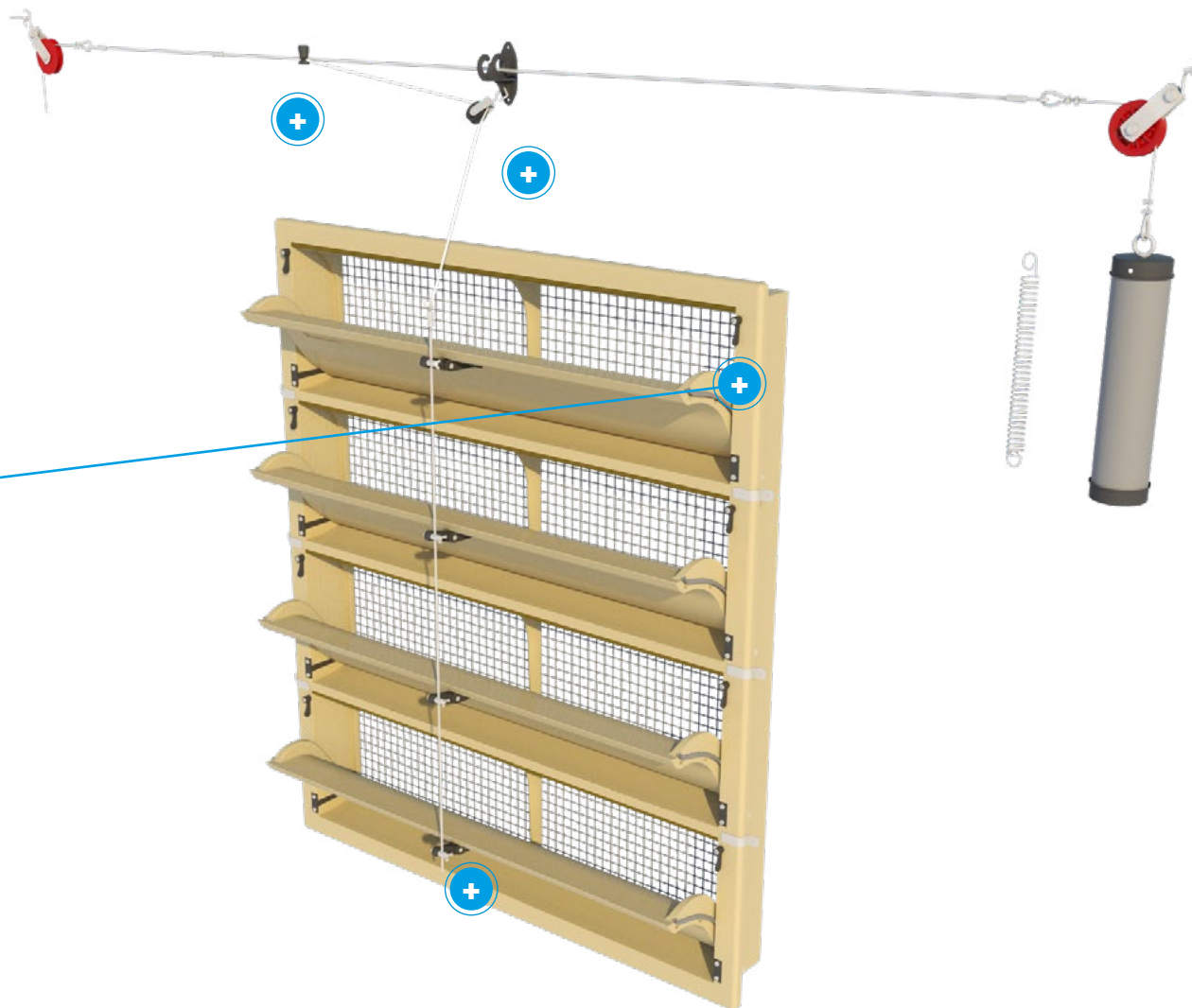
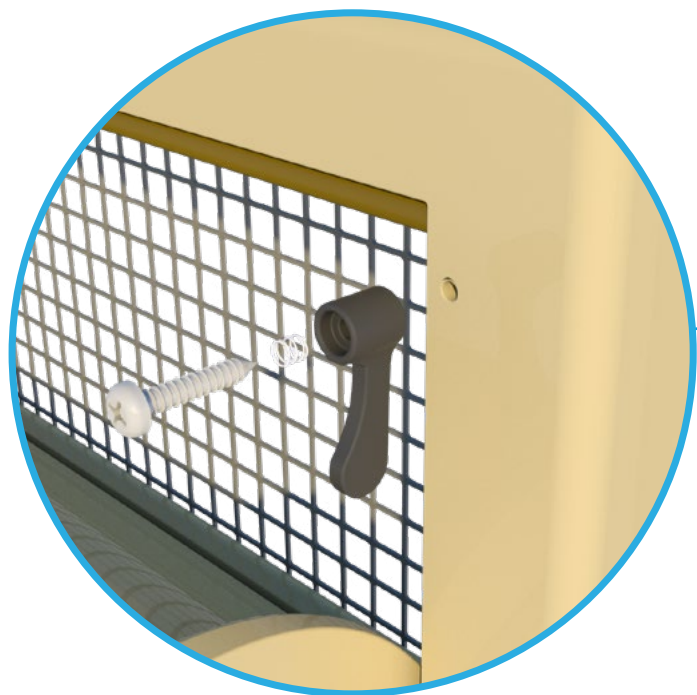

INFO

DATASHEET

ASSEMBLY

MOUNTING

WORKING

MAINTENANCE



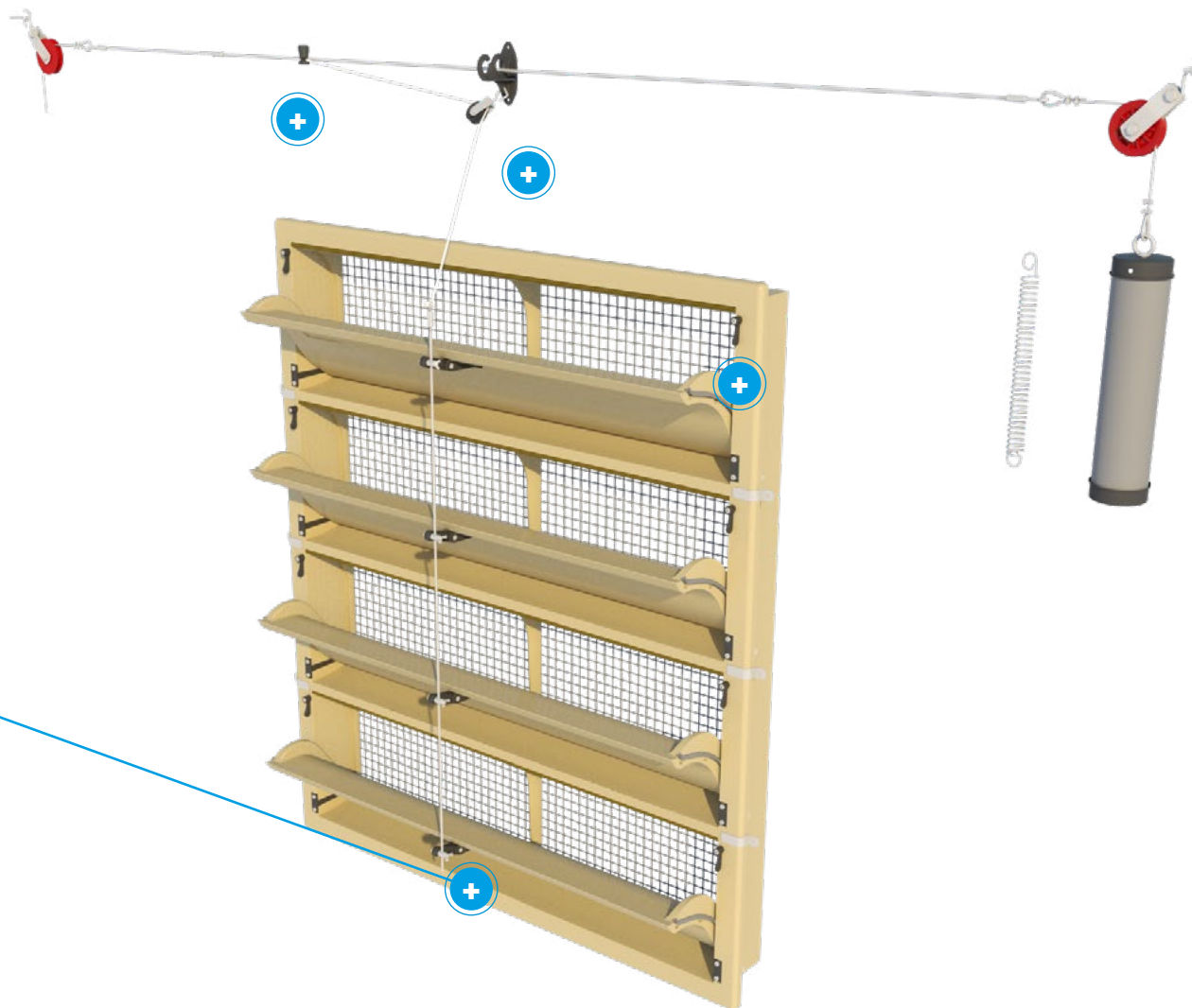
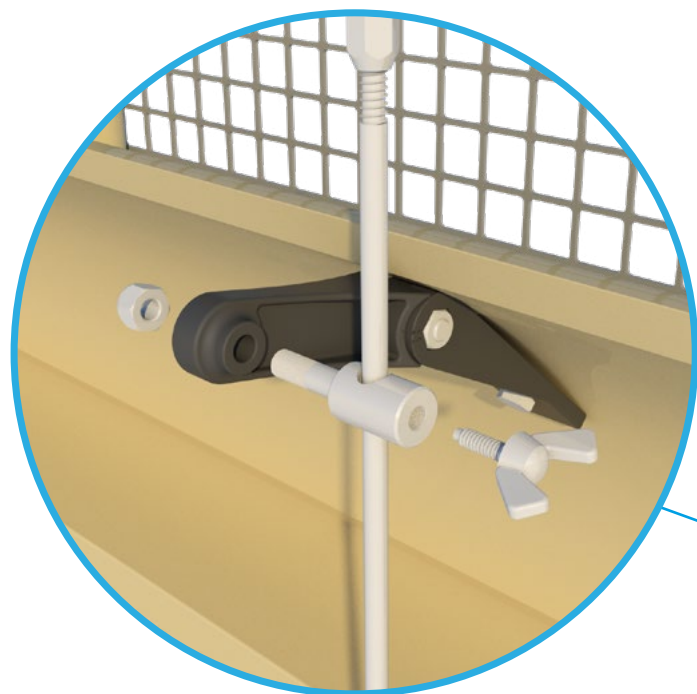

INFO

DATASHEET

ASSEMBLY

MOUNTING

WORKING

MAINTENANCE





VENTUM-4 MOUNTING

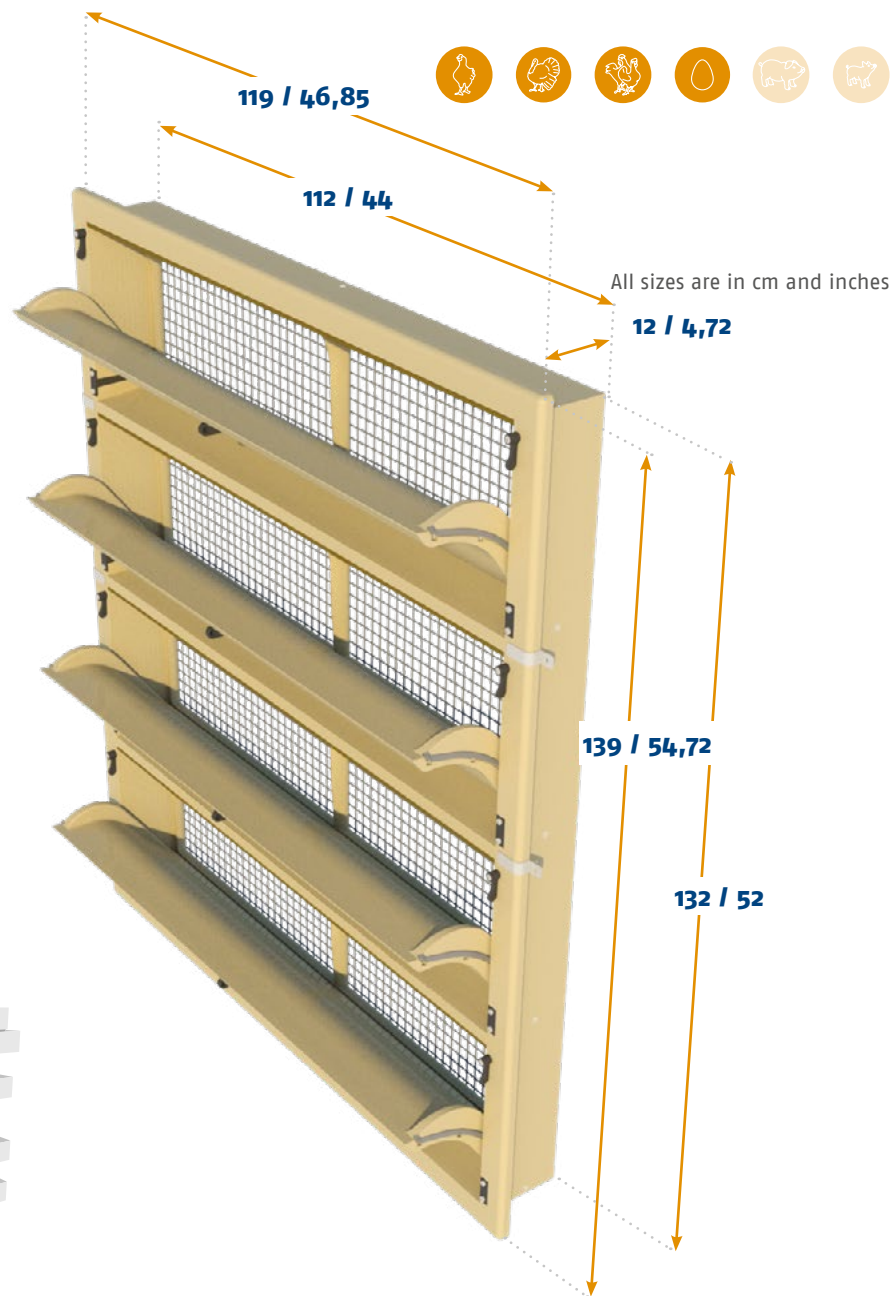
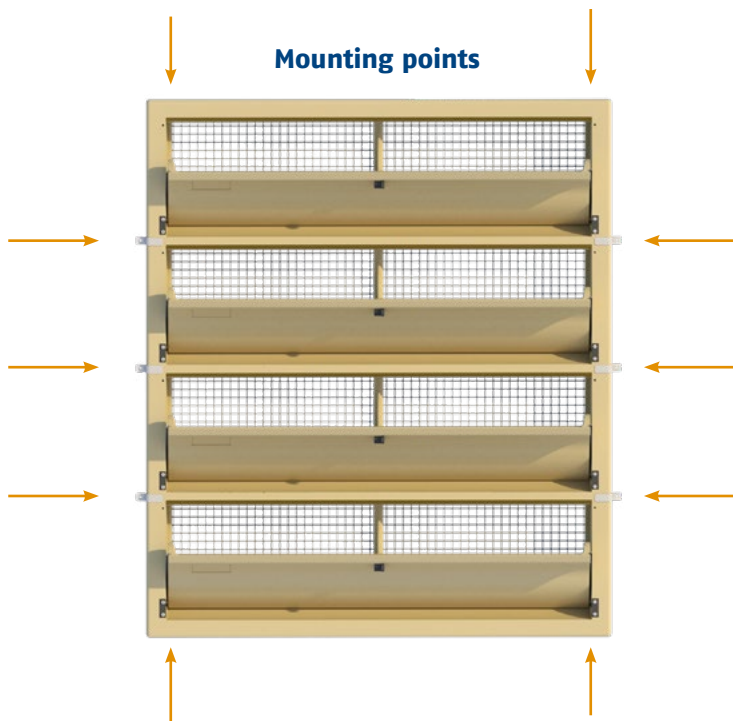

MOUNTING	
Mounting type	Wall
Mounting hole size	W 114 cm / 44,88 inch x H 134 cm / 52,76 inch

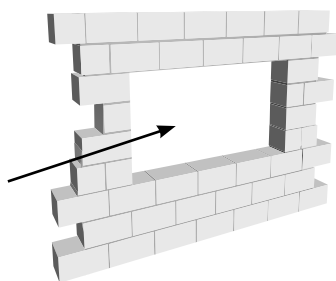

- INFO
- DATASHEET
- ASSEMBLY
- MOUNTING
- WORKING
- MAINTENANCE
- ☰

AIR FLOW

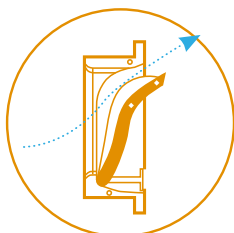

Bottom hinged inlet

Ventum inlets are bottom hinged, therefore also these modular tunnel units are bottom hinged. This means that at an early opening stage air does not flow underneath the inner flaps towards the animals. Instead air is guided upwards into the house.

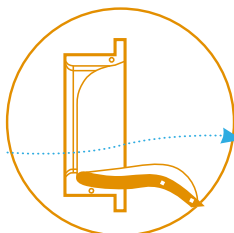

Curved inner flap

This inlet is equipped with a curved inner flap. Curved flaps guide the air upwards during minimum ventilation, but also downwards after a certain point of opening. This is ideal for houses where air should be directed directly towards or over the animals during maximum ventilation.

Working with end-weights or springs

We offer two products which can be used to keep tension on the main cable. A PVC cylinder which can be filled with concrete or sand to act as end-weight, or a spring that holds tension on the cable.

Balanced set-up

When placing the motor winch or actuator we normally suggest to divide the inlets in two groups. It is preferable to place the winch or actuator in the middle to equally divide the forces on the main cable.

(see ventilation concepts page for an example)

Use of closing catches

The closing catch on the inlet can be used to permanently close inlets for example during pre-heating. The closing catches can also be used to close certain inlets while continuing to use others. In that case the used inlets can be opened a bit further. In colder climates this can help to offer better resistance to freezing effects.

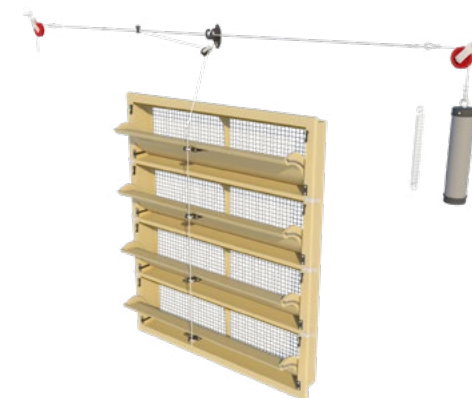

INFO

DATASHEET

ASSEMBLY

MOUNTING

WORKING

MAINTENANCE



VENTUM tunnel

The Ventum is developed to make our unique air inlet features and technologies available for American building and ventilation concepts. The dimensions of the Ventum are more universal making it easily usable in renovation projects where existing inlets need replacement. This inlet is suitable mostly for poultry houses since the curved inner valve helps to guide air downwards to the birds during maximum ventilation. The valve and frame of this inlet is equipped with wear resistant stripping all around to prevent air leakage and the curved inner corners of the frame help to optimize air intake. Our unique polyurethane formula and the use of air seals assures optimum insulation making the inlet ideal for extremely low temperatures.

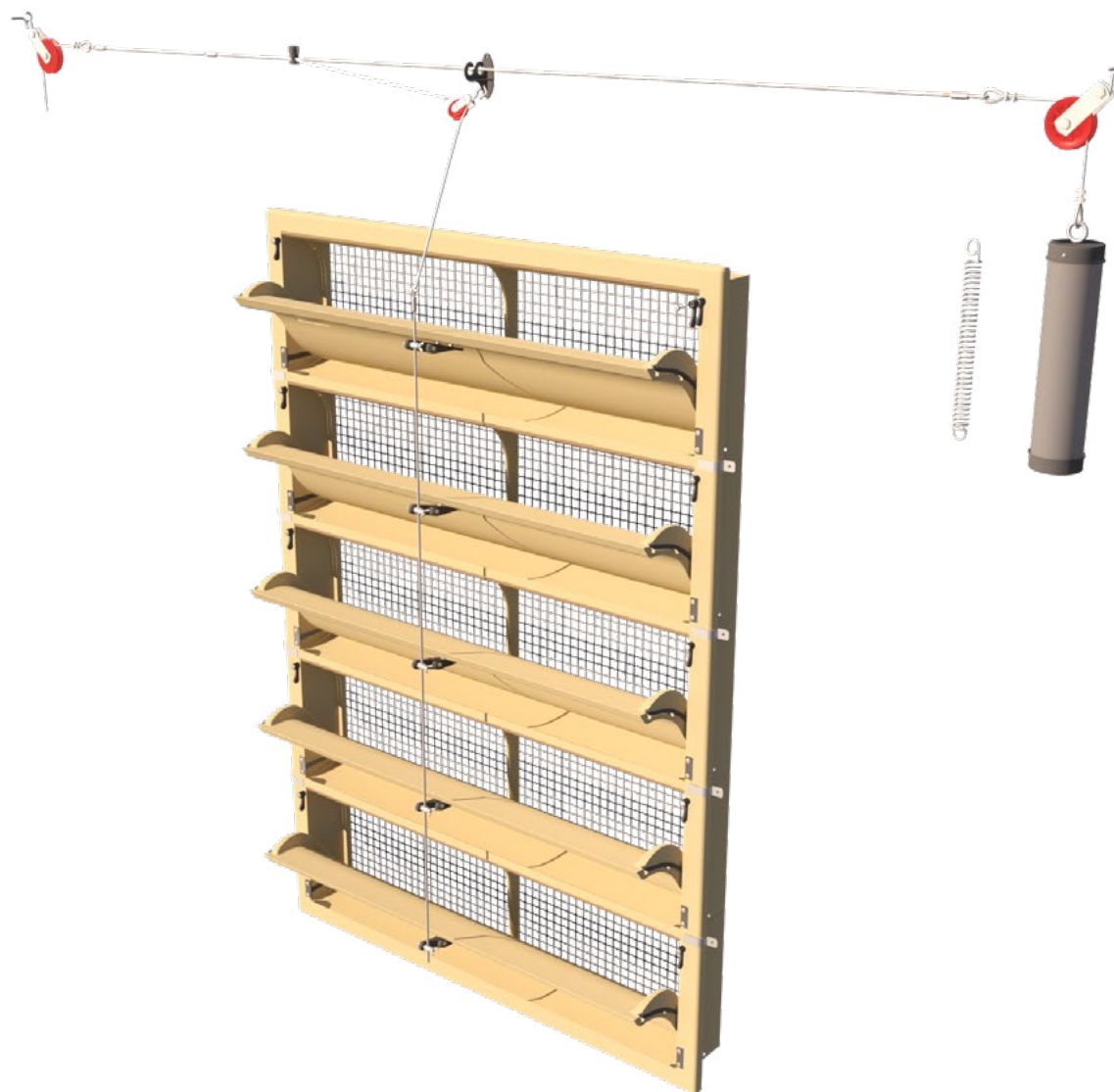

[INFO](#)

[DATASHEET](#)

[ASSEMBLY](#)

[MOUNTING](#)

[WORKING](#)

[MAINTENANCE](#)





VENTUM-5 DATASHEET



CAPACITY

Model	m ³ /h @ 10 Pa	m ³ /h @ 20 Pa	m ³ /h @ 40 Pa
Ventum-5:	17.400	24.500	34.750
	cfm @ 0.05 inH ₂ O	cfm @ 0.1 inH ₂ O	cfm @ 0.15 inH ₂ O
	11.450	16.090	19.571

INFORMATION

Run	40 cm / 15.7 Inch
Force	15 kg / 147 Newton
Number / pallet (1,30 x 1,00 x 2,50m / 51 x 39 x 98inch)	7
Weight / per tunnel	24 kg / 53 lbs
Arm position	3+

OPTIONAL ACCESSORIES

TPI-119 (*5)	Wire Mesh synthetic
TPI-225	Connection set
TPI-308 (*10)	Closing catch

AIR FLOW

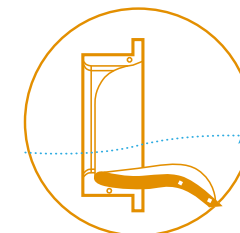
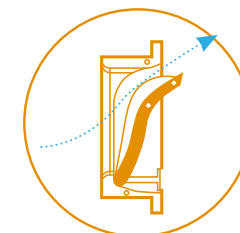

INFO

DATASHEET

ASSEMBLY

MOUNTING

WORKING

MAINTENANCE





TPI-204C

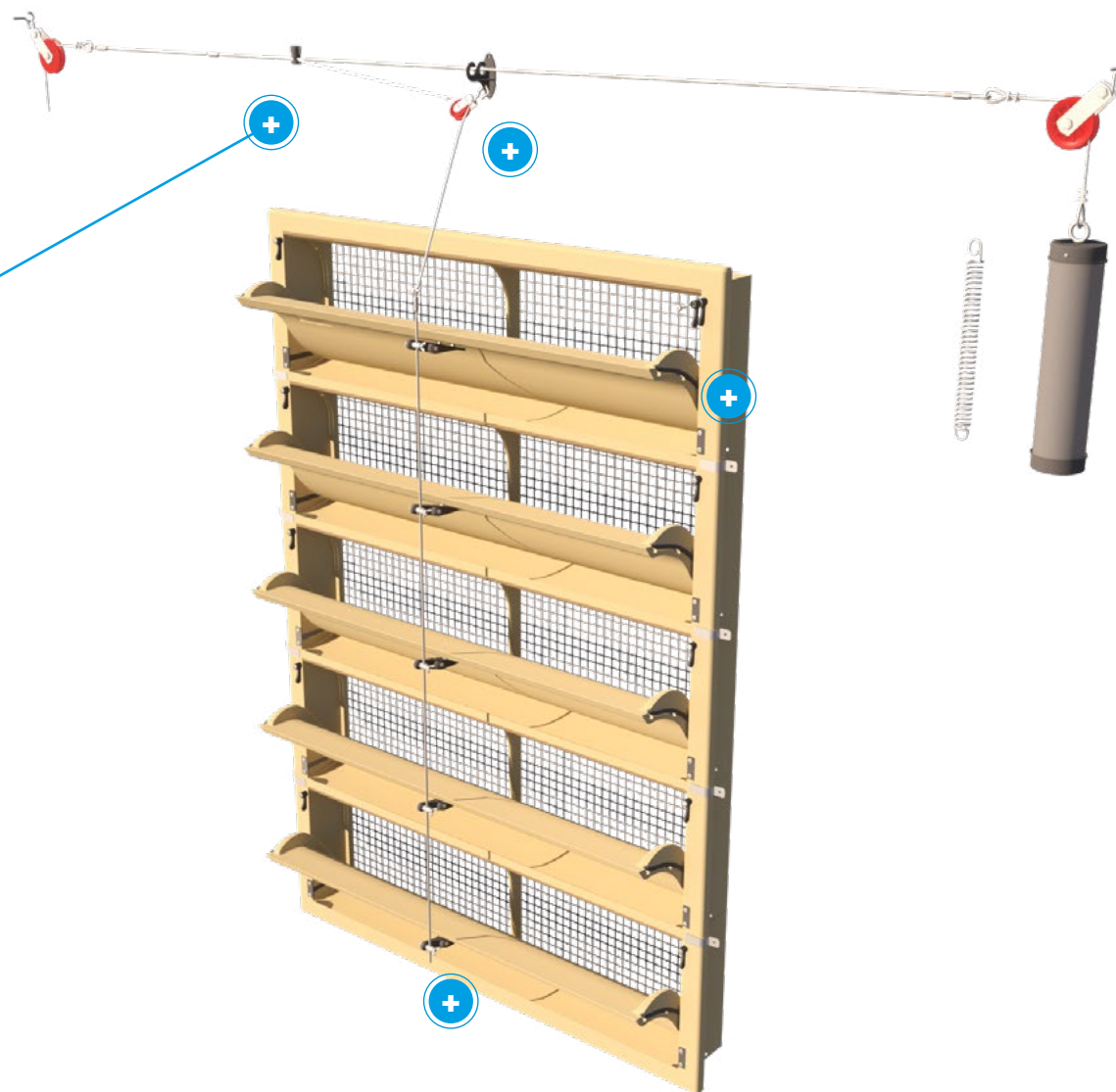

INFO

DATASHEET

ASSEMBLY

MOUNTING

WORKING

MAINTENANCE



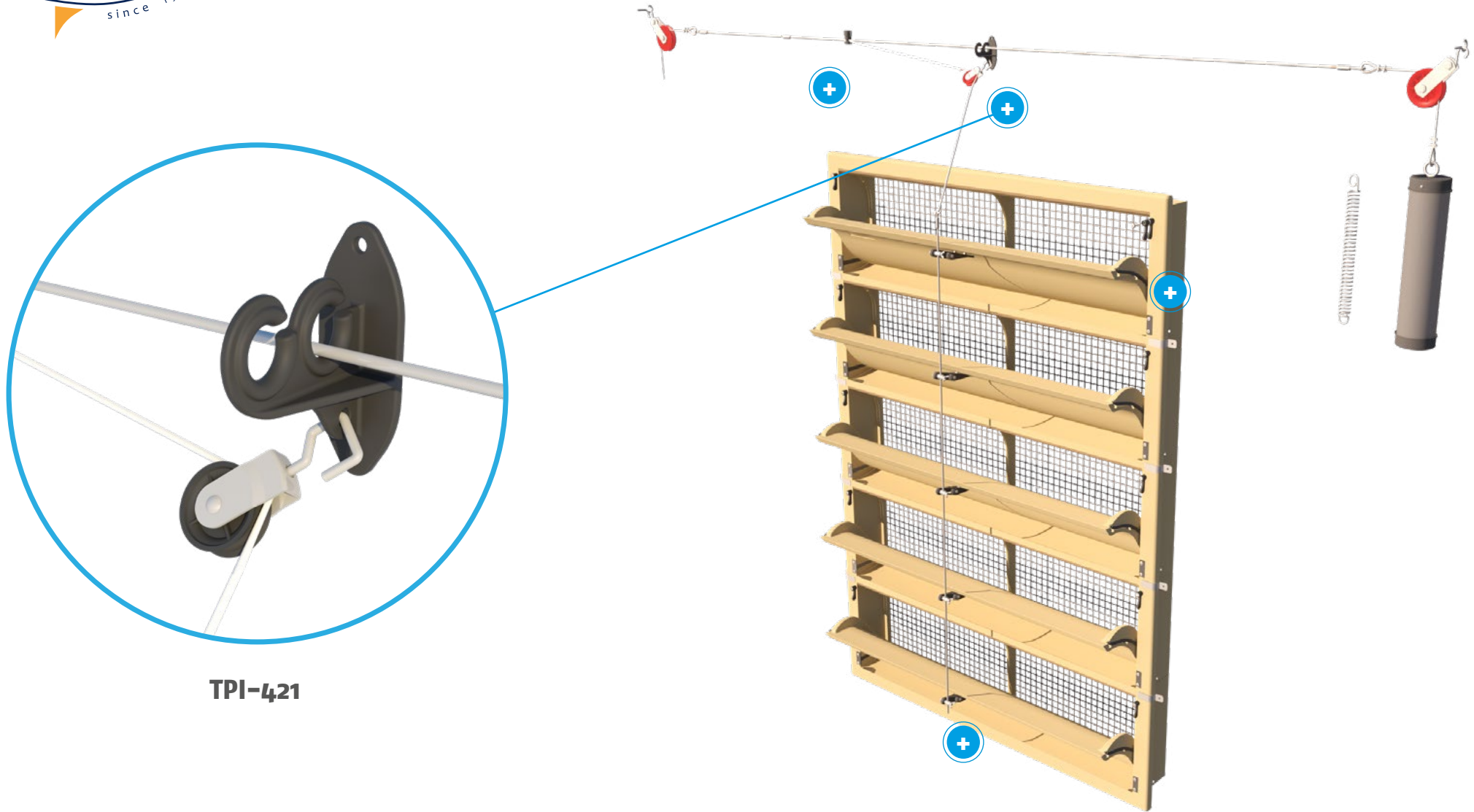

TPI-421

[INFO](#)

[DATASHEET](#)

[ASSEMBLY](#)

[MOUNTING](#)

[WORKING](#)

[MAINTENANCE](#)



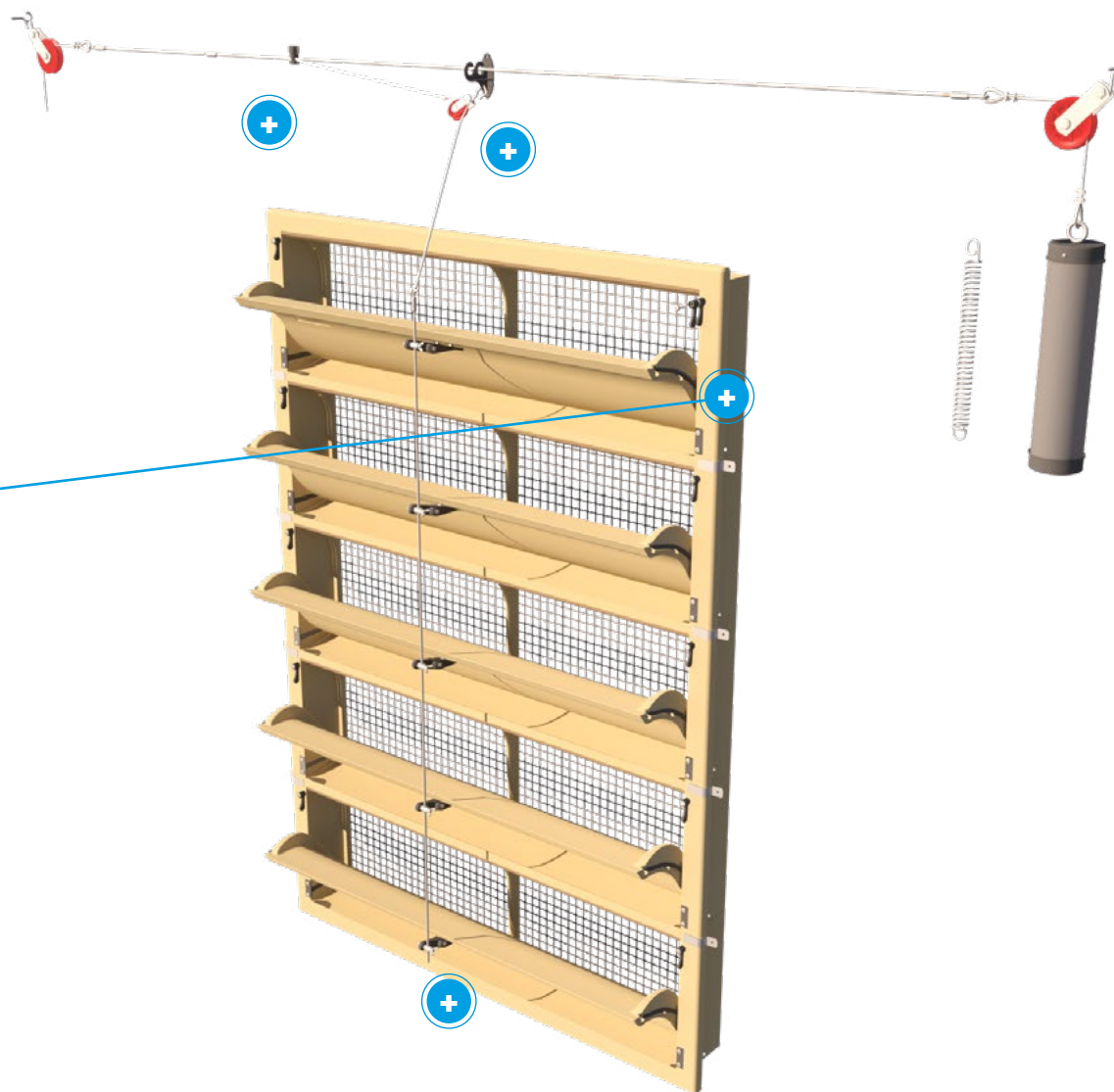
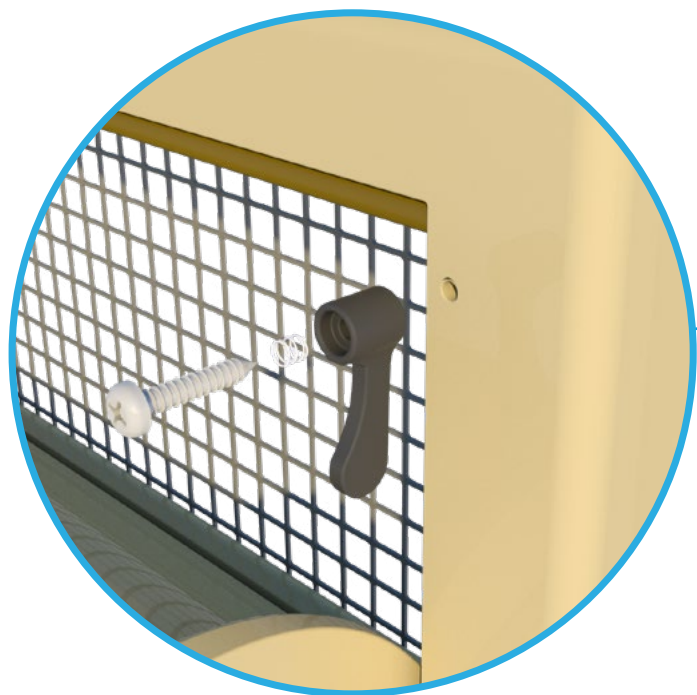

INFO

DATASHEET

ASSEMBLY

MOUNTING

WORKING

MAINTENANCE



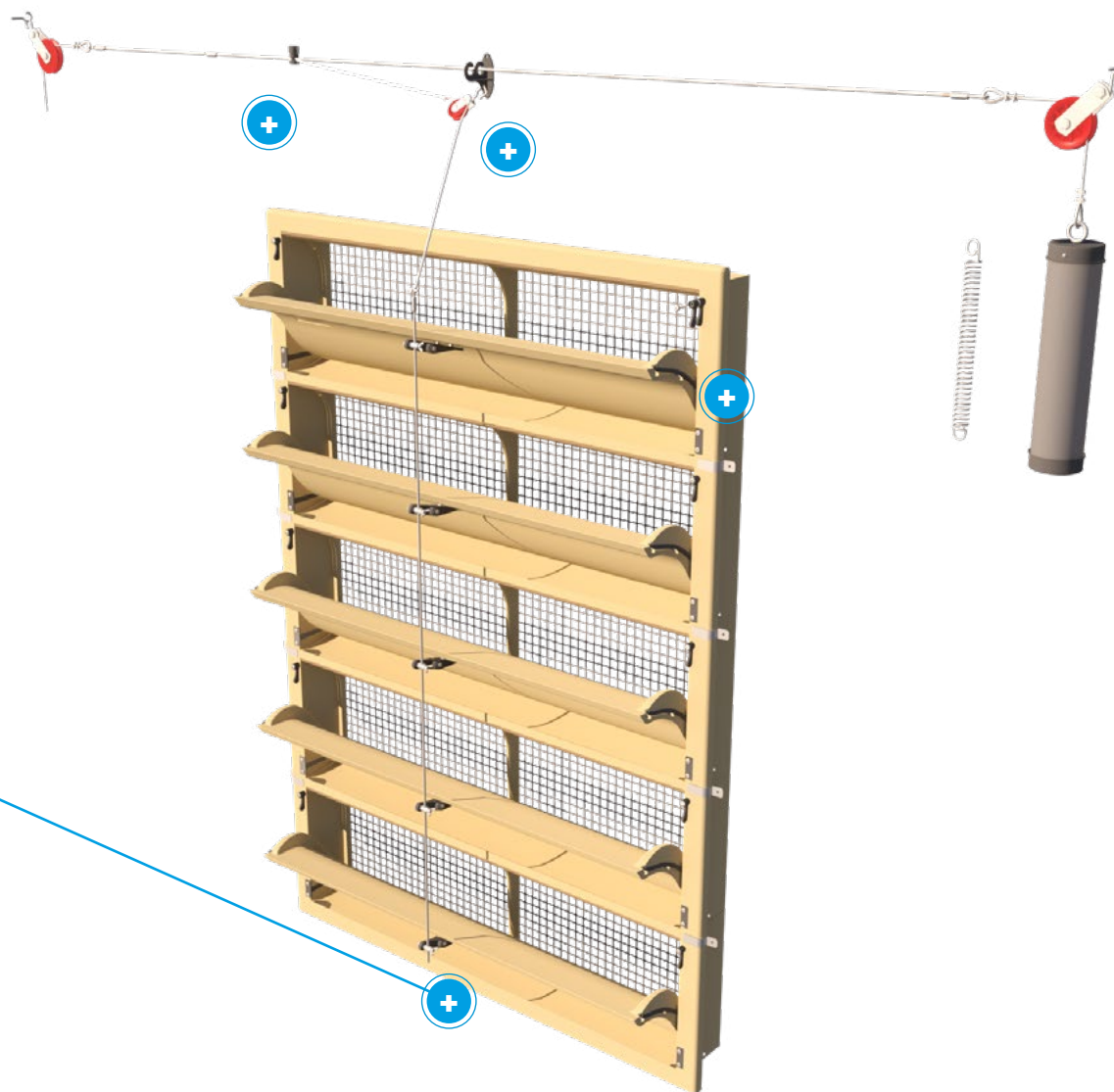
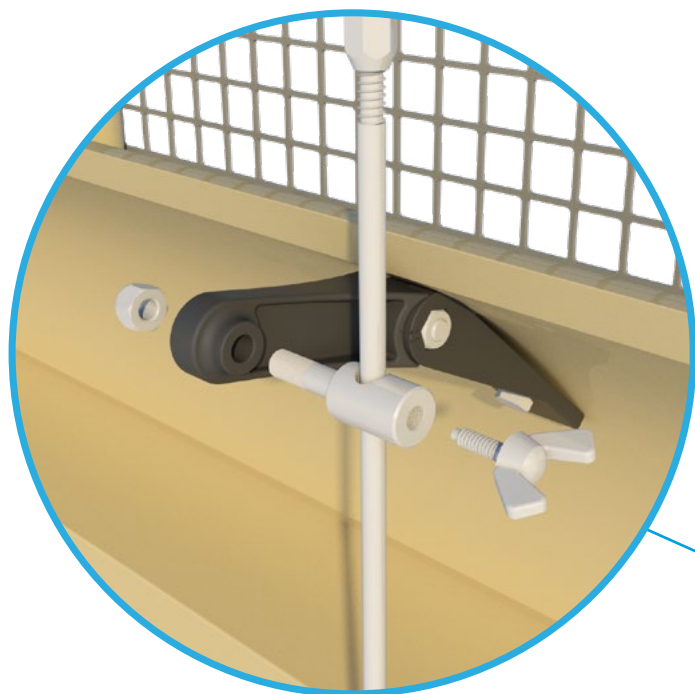

INFO

DATASHEET

ASSEMBLY

MOUNTING

WORKING

MAINTENANCE





VENTUM-5 MOUNTING



All sizes are in cm and inches

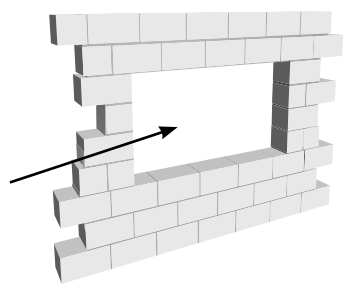
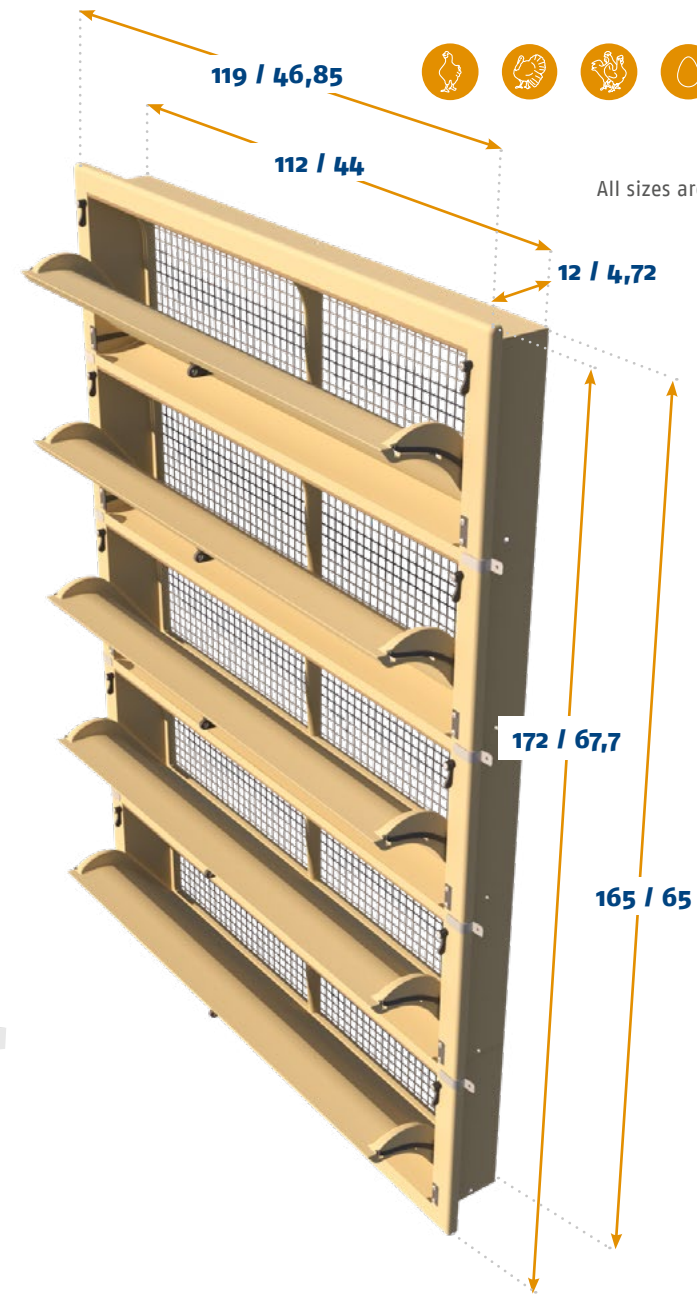
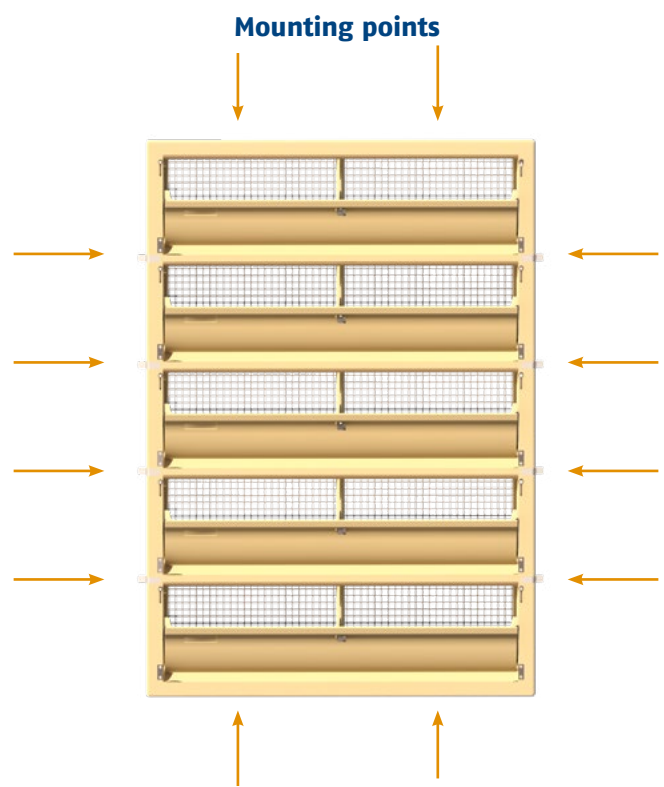

MOUNTING	
Mounting type	Wall
Mounting hole size	W 114 cm / 44,88 inch x H 167 cm / 65,7 inch

AIR FLOW

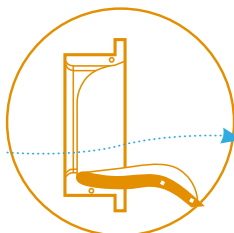
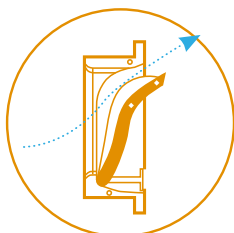

Bottom hinged inlet

Ventum inlets are bottom hinged, therefore also these modular tunnel units are bottom hinged. This means that at an early opening stage air does not flow underneath the inner flaps towards the animals. Instead air is guided upwards into the house.

Curved inner flap

This inlet is equipped with a curved inner flap. Curved flaps guide the air upwards during minimum ventilation, but also downwards after a certain point of opening. This is ideal for houses where air should be directed directly towards or over the animals during maximum ventilation.

Working with end-weights or springs

We offer two products which can be used to keep tension on the main cable. A PVC cylinder which can be filled with concrete or sand to act as end-weight, or a spring that holds tension on the cable.

Balanced set-up

When placing the motor winch or actuator we normally suggest to divide the inlets in two groups. It is preferable to place the winch or actuator in the middle to equally divide the forces on the main cable.

(see ventilation concepts page for an example)

Use of closing catches

The closing catch on the inlet can be used to permanently close inlets for example during pre-heating. The closing catches can also be used to close certain inlets while continuing to use others. In that case the used inlets can be opened a bit further. In colder climates this can help to offer better resistance to freezing effects.



INFO

DATASHEET

ASSEMBLY

MOUNTING

WORKING

MAINTENANCE



AERON

This inlet offers the best features required in the market today. With a middle hinged inner valve the air also flows underneath the valve when it is 30% opened. The inner valve is equipped with seals on the sides and top, to prevent air leakage. The house also has a seal in the bottom for perfect closure when the valve is shut. Newly designed clock springs on each side of the valve help open the inlet and keep control.

The shape of the house, designed with airflow simulation software, guarantees optimal performance. The combination of materials and air seals help to make this inlet suitable in many different climates. The W-shape of the inner valve helps to create jets which give perfect control during minimum ventilation. During maximum ventilation air is also guided downwards to the animals to deliver a cooling effect.

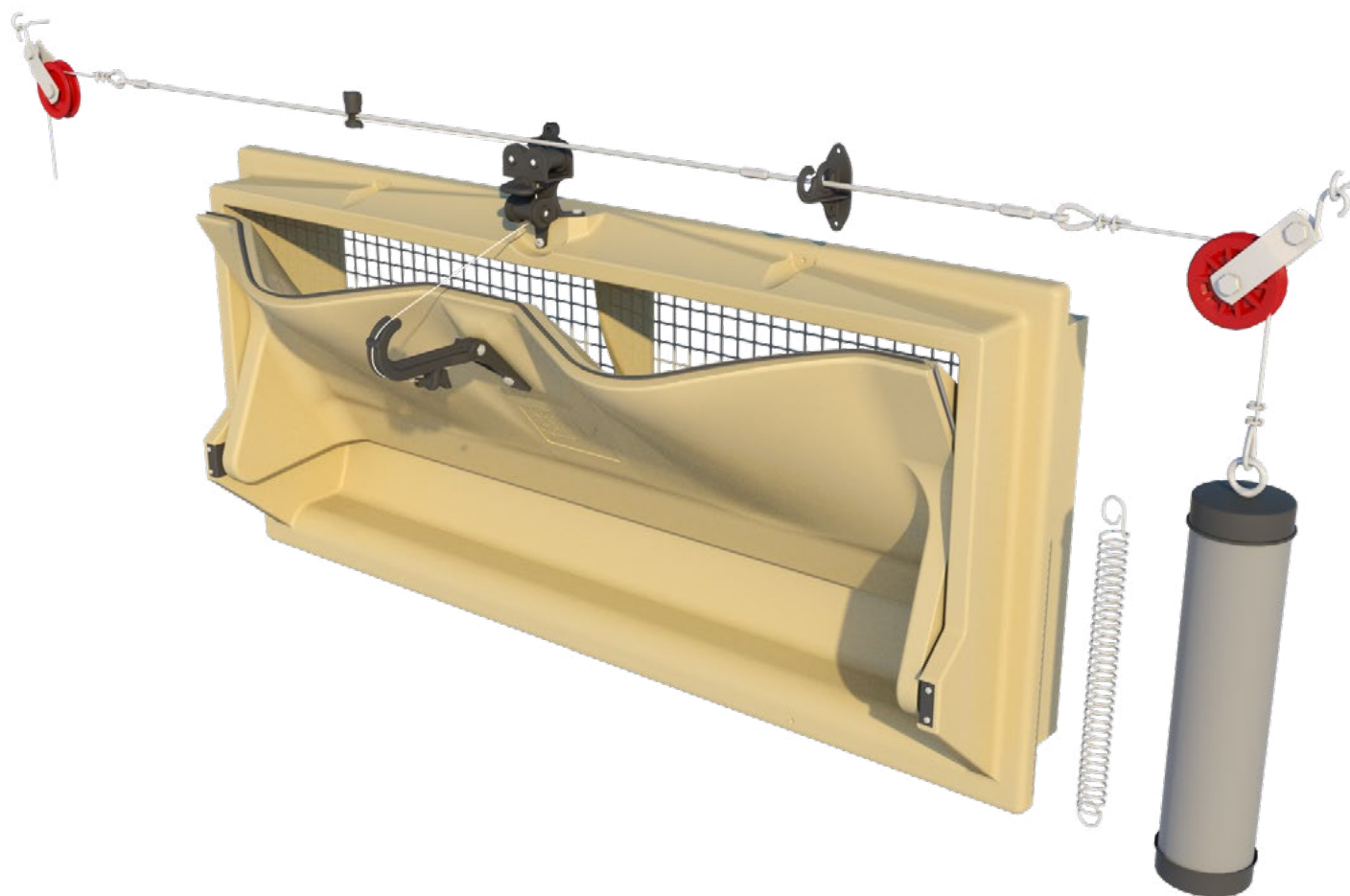

INFO

DATASHEET

ASSEMBLY

MOUNTING

WORKING

MAINTENANCE





AERON DATASHEET



CAPACITY

Model	m ³ /h @ 10 Pa	m ³ /h @ 20 Pa	m ³ /h @ 40 Pa
Aeron	3100	4400	6250
	cfm @ 0.05 inH ₂ O	cfm @ 0.1 inH ₂ O	cfm @ 0.15 inH ₂ O
	2040	2890	3552

INFORMATION

Run	55 cm / 21.7 Inch
Force	4.5 kg / 44 Newton
Number / pallet	24
(1,30 x 1,00 x 2,60m / 51,2 x 39 x 102inch)	
Weight / per inlet	5,3 kg / 11.7 lbs
Volume / per box	12
Arm position	2

OPTIONAL ACCESSORIES

TPI-120	Wire mesh synthetic
TPI-204c	Connection set
TPI-423	Pulley Unit + Closing Catch

AIR FLOW

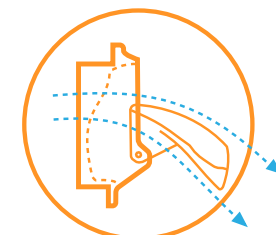

INFO

DATASHEET

ASSEMBLY

MOUNTING

WORKING

MAINTENANCE





TPI-204C

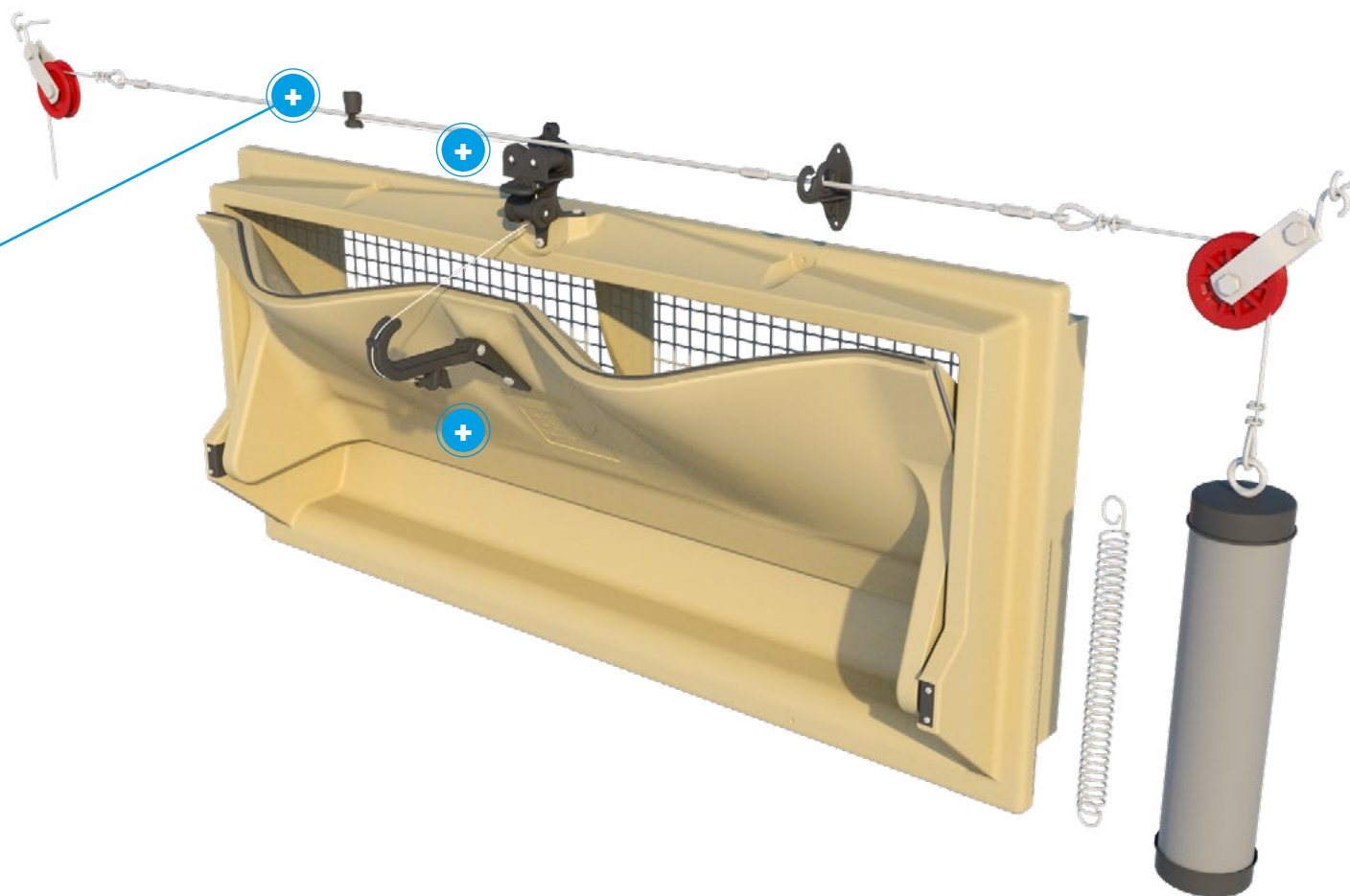

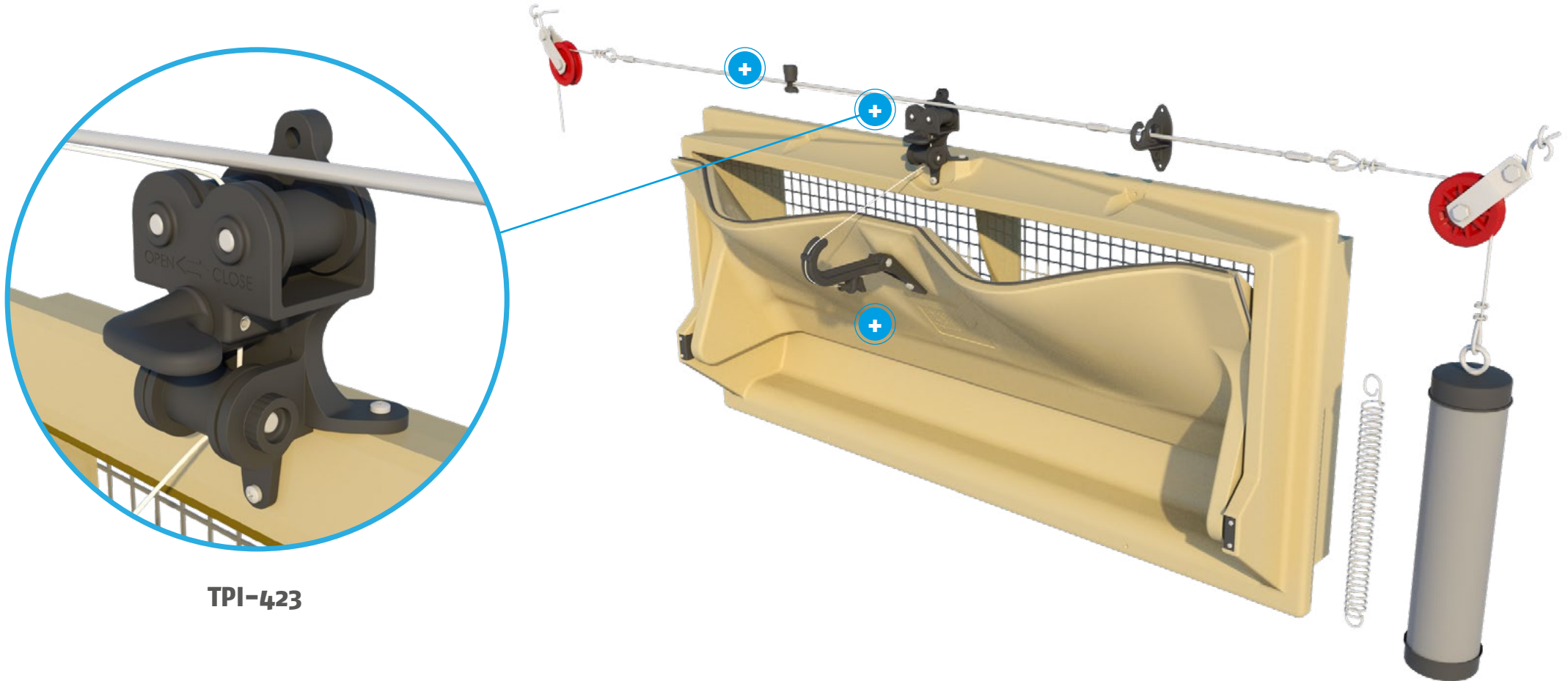

TPI-423

INFO

DATASHEET

ASSEMBLY

MOUNTING

WORKING

MAINTENANCE



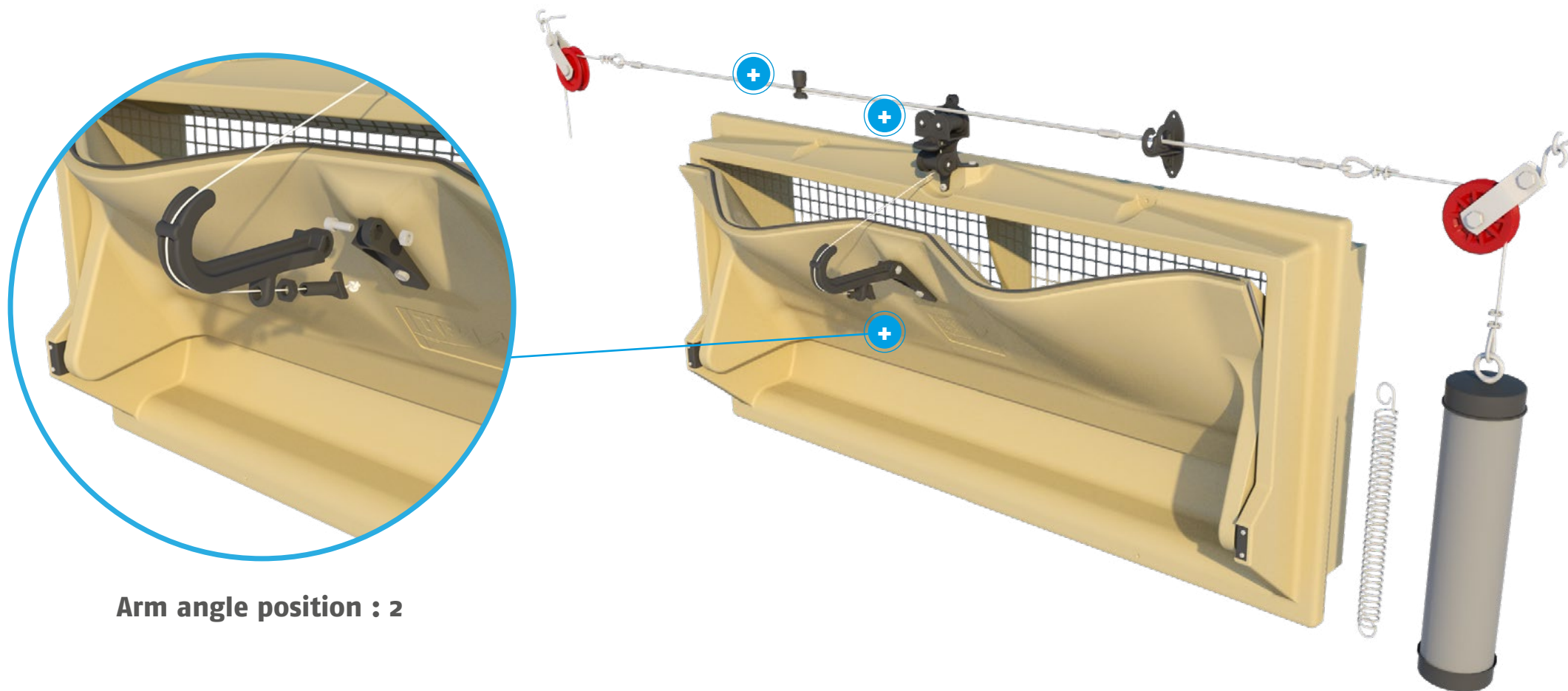

Arm angle position : 2

INFO

DATASHEET

ASSEMBLY

MOUNTING

WORKING

MAINTENANCE



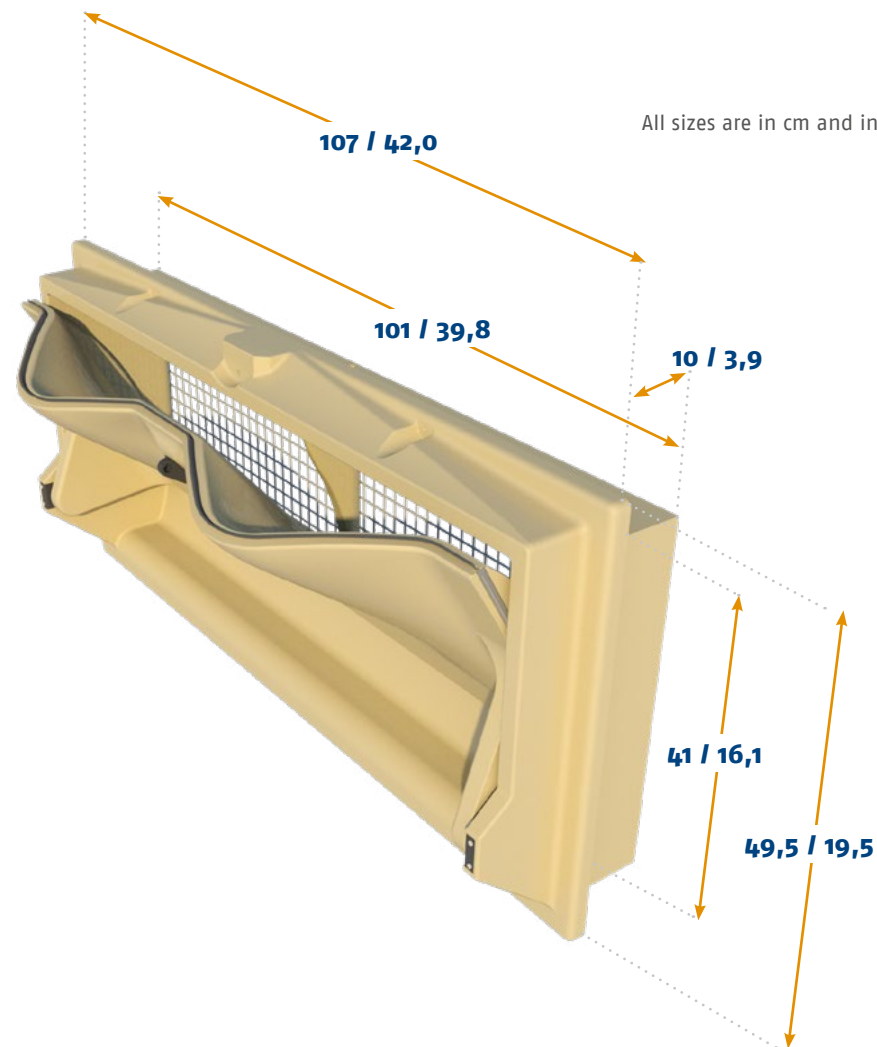
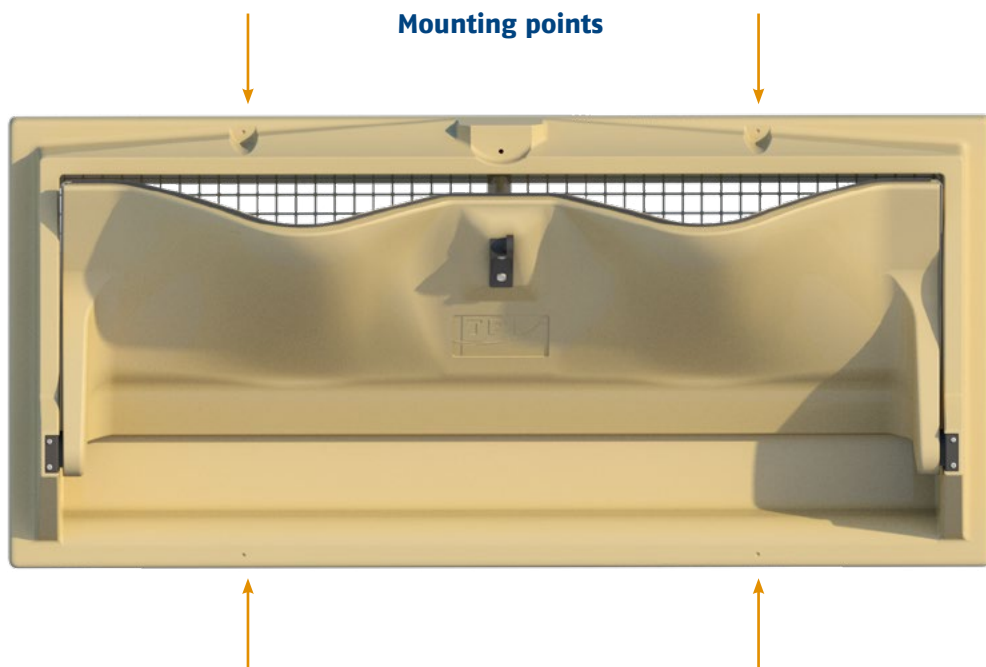

MOUNTING	
Mounting type	Wall
Mounting hole size	103 cm / 40,6 inch x 43 cm / 16,9 inch

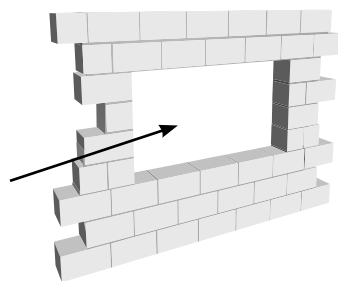

AIR FLOW

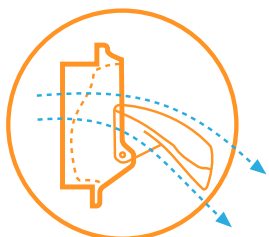
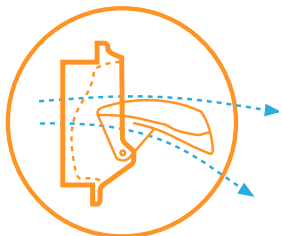
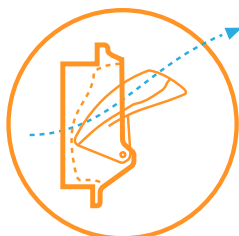

Opening and closing of inlets

Our standard inlets are spring-opened which means that without force on the main cable they will open automatically. The air inlets are connected to a main cable which can be pulled by a motor winch or actuator. In a normal situation, when pulling on the main cable the inlets are closing. The spring or end weight at the other end of the main cable makes sure the main cable is held straight and in place.

Self-closing inlets and delayed opening

A major part of our program can also be produced as a self-closing air inlet. In this scenario the opening and closing works the opposite way. The hanging pulleys have to be installed on the bottom flange and the central plastic control arm needs to guide the nylon cord downwards. The main cable has to be mounted underneath the inlets. With this set-up a system of delayed opening can be made, meaning that by adjusting the angle of the central control arm you can determine how early or late an inlet opens compared to another on the same line.

Making adjustments

By using the nylon bolt and nut small adjustments can be made to make sure all inlets are closing and opening correctly. The nylon cable clamp and cord can also be used to make small adjustments.

Working with springs or end-weights

At the opposite end on the main cable of where the motor winch or actuator is located there are two options to choose from: an end-weight which can be filled with concrete or sand, or a spring that holds tension on the cable.

Balanced set-up

When placing the motor winch or actuator we normally suggest to divide the inlets in two groups. It is often preferable to place the motor winch or actuator in the middle to equally split the forces that are exerted upon the inlets and winch.

Use of closing catches

The closing catch on the inlet can be used to permanently close inlets for example during pre-heating. The closing catches can also be used to close certain inlets while continuing to use others therefore offering the opportunity to open the inlets which are in use a bit further. In colder climates this can help to offer better resistance to freezing effects.

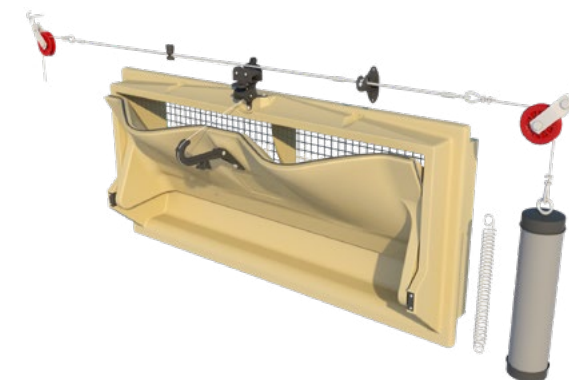
[INFO](#)
[DATASHEET](#)
[ASSEMBLY](#)
[MOUNTING](#)
[WORKING](#)
[MAINTENANCE](#)

VUELA

This inlet has the best features required for your house today. Opened over 30%, air starts to flow also underneath the middle hinged inner valve. To prevent air leakage the inner valve is equipped with seals on two sides. Seals in the top and bottom of the house ensures absolute airtightness. Newly designed clock springs on each side controls it with perfect precision.

The house shape is designed with special airflow simulation software and that greatly improves inlet performance. The combination of polyurethane and seals make Vuela suitable for different climates. The V-Shape of the inner valve is designed in such a way that it creates a Jetstream with optimal control during minimum ventilation. The inlet has a minimum capacity of 80 m³/h at 10 Pa and can still throw the air to the center of the house.

You can update your house easily by swapping your current 145-VFG or 145-VFG-C inlets with Vuela.

[INFO](#)[DATASHEET](#)[ASSEMBLY](#)[MOUNTING](#)[WORKING](#)[MAINTENANCE](#)



VUELA DATASHEET



CAPACITY

Model	m ³ /h @ 10 Pa	m ³ /h @ 20 Pa	m ³ /h @ 40 Pa
Vuela	1560	2220	3140
	cfm @ 0.05 inH ₂ O	cfm @ 0.1 inH ₂ O	cfm @ 0.15 inH ₂ O
	1090	1541	1887

INFORMATION

Run	38 cm / 14.9 Inch
Force	3.5 kg / 34 Newton
Number / pallet (1,20 x 0,80 x 2,40m / 47,2 x 31,5 x 94,5inch)	54
Weight / per inlet	1,8 kg / 4.0 lbs
Volume / per box	27
Arm position	2

OPTIONAL ACCESSORIES

TPI-121	Wire mesh galvanized
TPI-204c	Connection set
TPI-423	Pulley Unit + Closing Catch

AIR FLOW

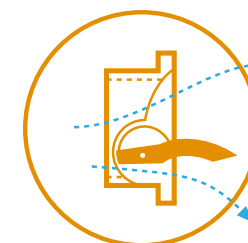

INFO

DATASHEET

ASSEMBLY

MOUNTING

WORKING

MAINTENANCE



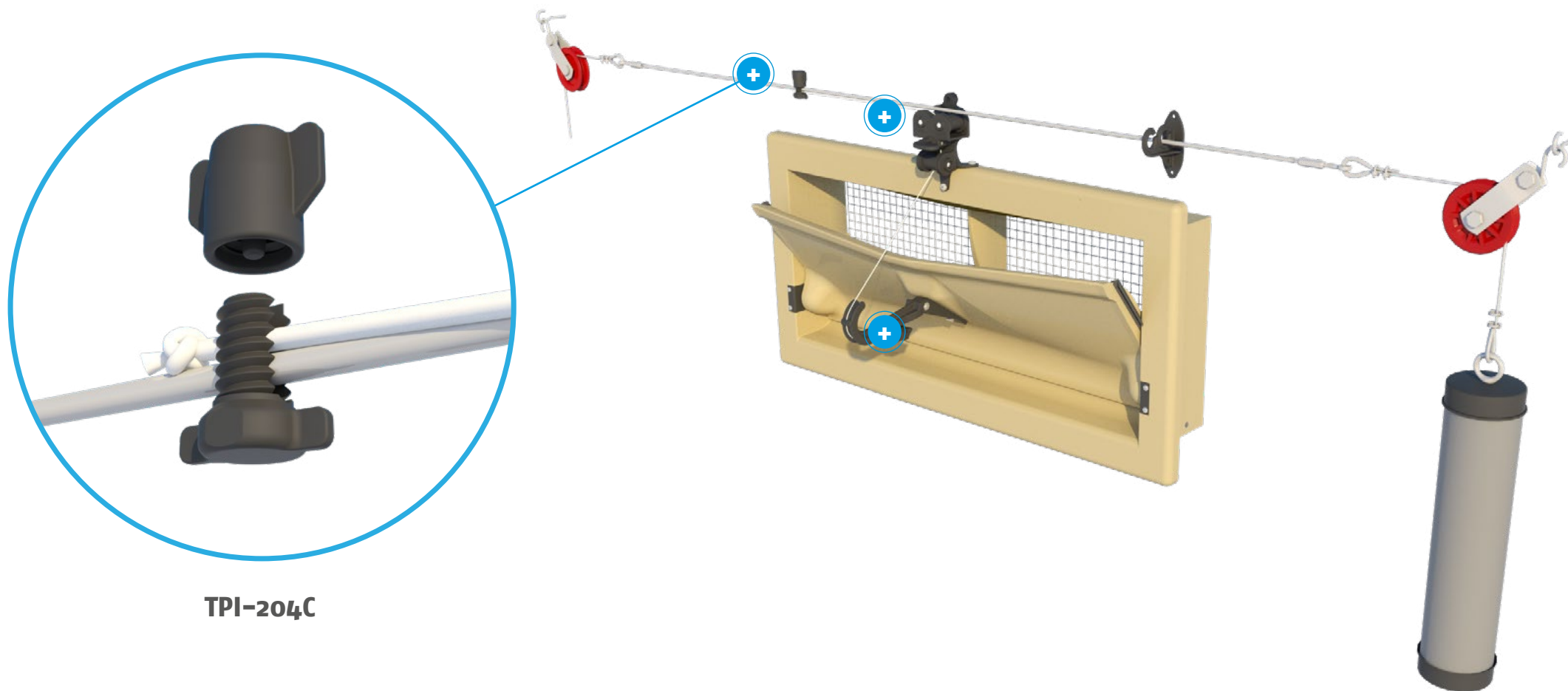

TPI-204C

INFO

DATASHEET

ASSEMBLY

MOUNTING

WORKING

MAINTENANCE



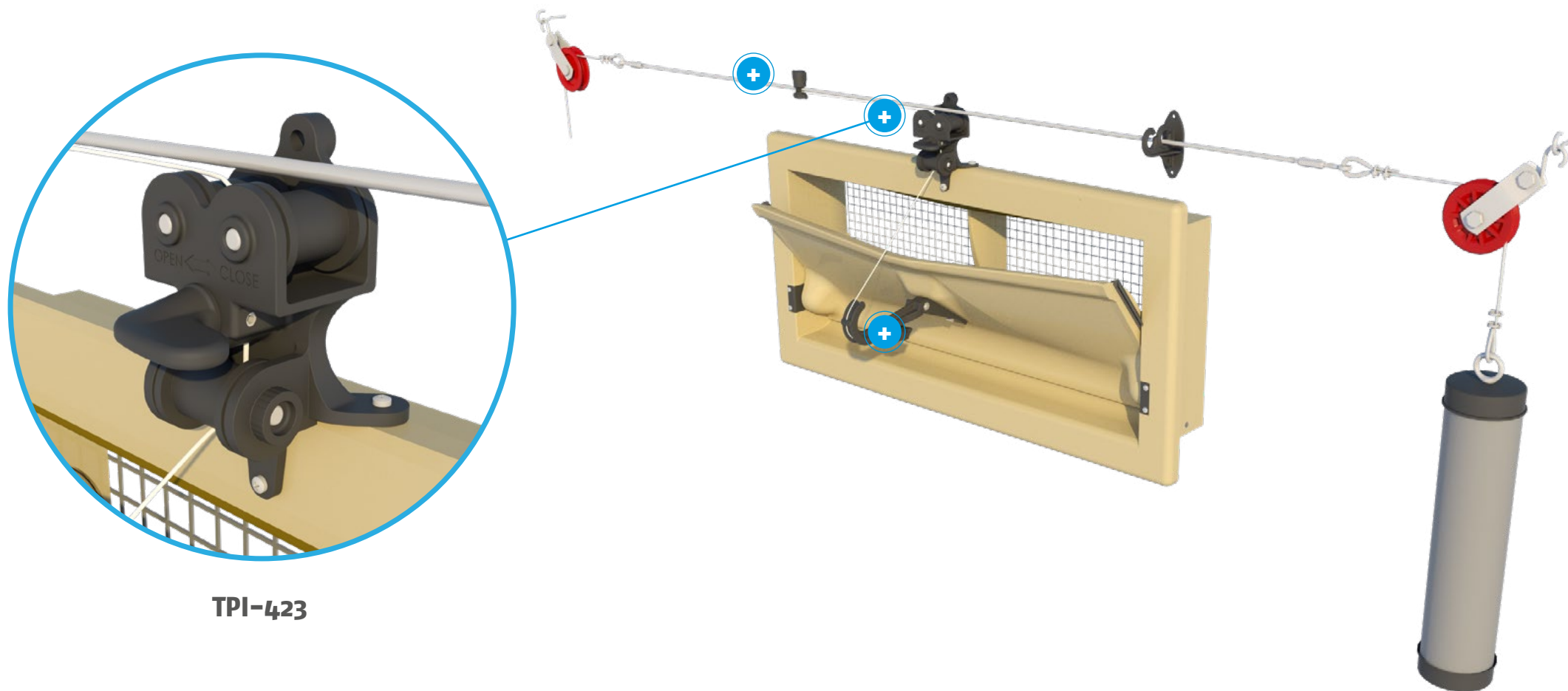

TPI-423

[INFO](#)

[DATASHEET](#)

[ASSEMBLY](#)

[MOUNTING](#)

[WORKING](#)

[MAINTENANCE](#)



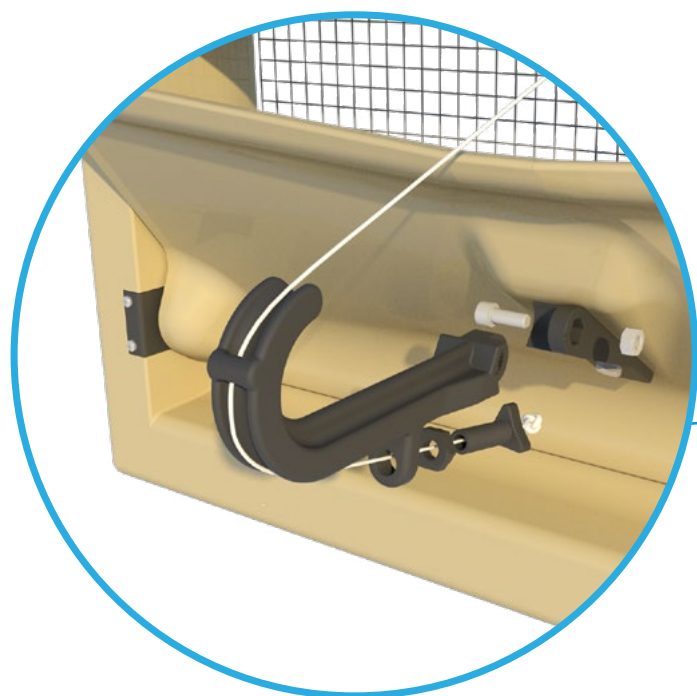

Arm angle position : 2

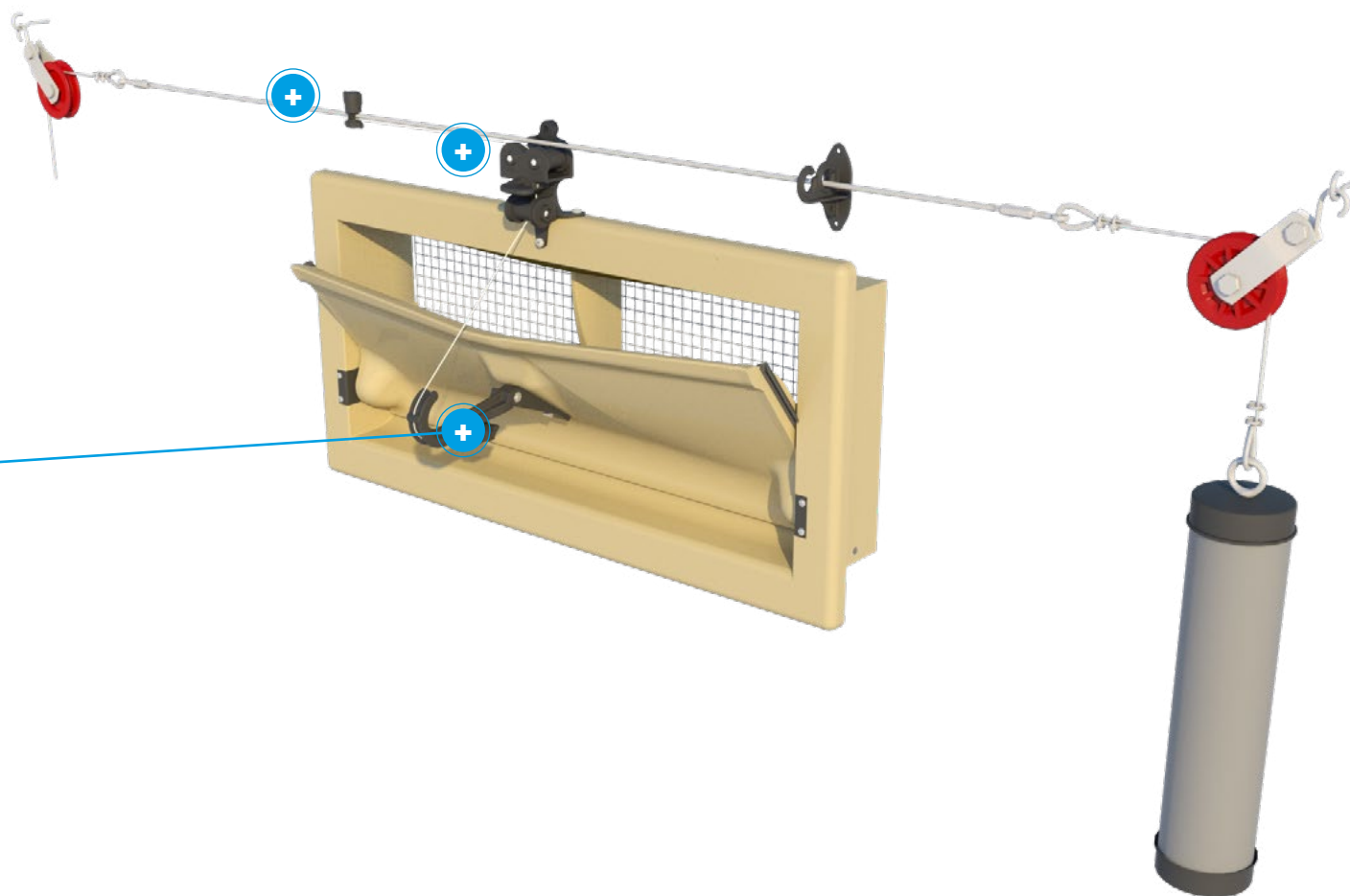

All sizes are in cm and inches

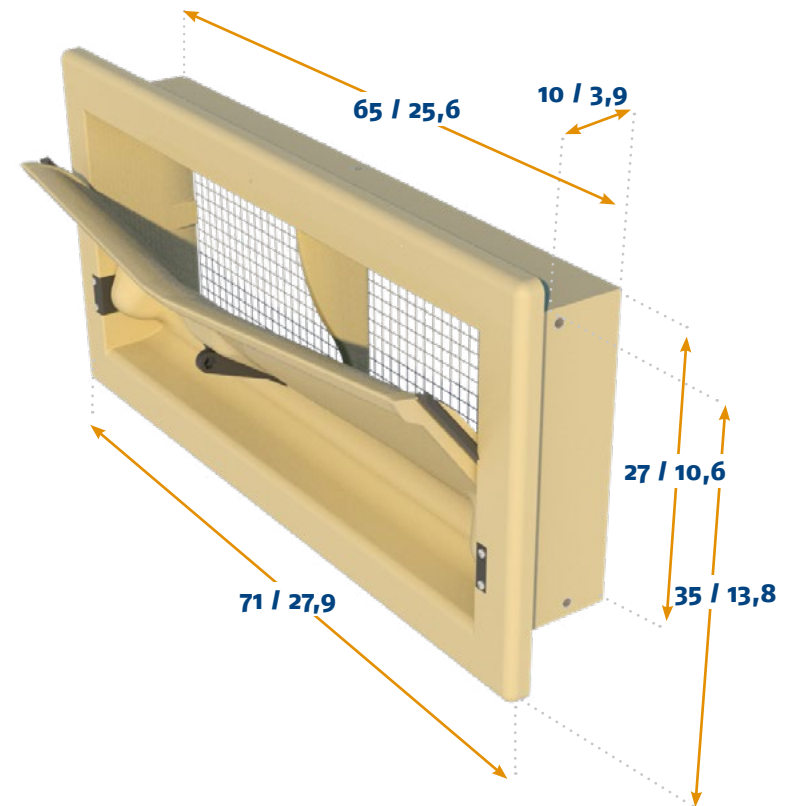
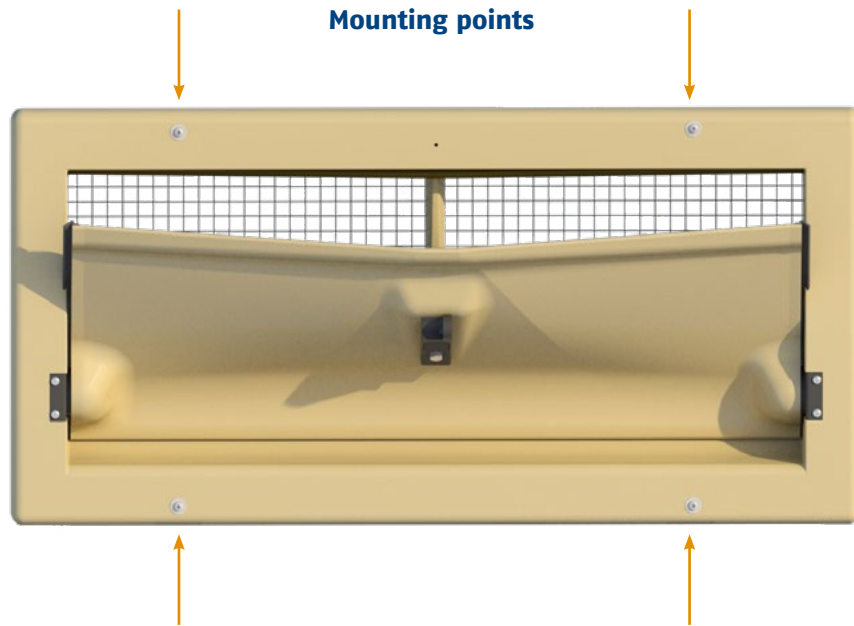

MOUNTING

Mounting type	Wall
Mounting hole size	67 cm / 26,4 inch x 29 cm / 11,5 inch

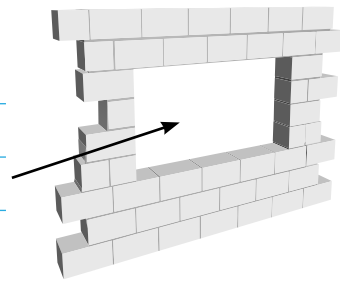

INFO

DATASHEET

ASSEMBLY

MOUNTING

WORKING

MAINTENANCE



AIR FLOW

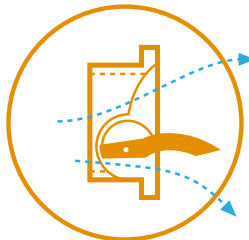
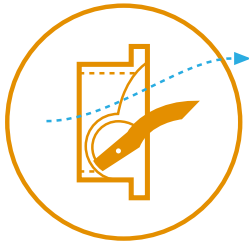

Opening and closing of inlets

Our standard inlets are spring-opened which means that without force on the main cable they will open automatically. The air inlets are connected to a main cable which can be pulled by a motor winch or actuator. In a normal situation, when pulling on the main cable the inlets are closing. The spring or end weight at the other end of the main cable makes sure the main cable is held straight and in place.

Self-closing inlets and delayed opening

A major part of our program can also be produced as a self-closing air inlet. In this scenario the opening and closing works the opposite way. The hanging pulleys have to be installed on the bottom flange and the central plastic control arm needs to guide the nylon cord downwards. The main cable has to be mounted underneath the inlets. With this set-up a system of delayed opening can be made, meaning that by adjusting the angle of the central control arm you can determine how early or late an inlet opens compared to another on the same line.

Making adjustments

By using the nylon bolt and nut small adjustments can be made to make sure all inlets are closing and opening correctly. The nylon cable clamp and cord can also be used to make small adjustments.

Working with springs or end-weights

At the opposite end on the main cable of where the motor winch or actuator is located there are two options to choose from: an end-weight which can be filled with concrete or sand, or a spring that holds tension on the cable.

Balanced set-up

When placing the motor winch or actuator we normally suggest to divide the inlets in two groups. It is often preferable to place the motor winch or actuator in the middle to equally split the forces that are exerted upon the inlets and winch.

Use of closing catches

The closing catch on the inlet can be used to permanently close inlets for example during pre-heating. The closing catches can also be used to close certain inlets while continuing to use others therefore offering the opportunity to open the inlets which are in use a bit further. In colder climates this can help to offer better resistance to freezing effects.



INFO

DATASHEET

ASSEMBLY

MOUNTING

WORKING

MAINTENANCE



6000-VFG

This inlet is by far our biggest wall inlet in the familiar rectangular shape. This inlet is controlled by two arms to offer maximum control and precision. This inlet is designed with the option to combine multiple inlets into a complete tunnel unit. This version is equipped with a bent inner valve which also guides air down after being opened over 35%.

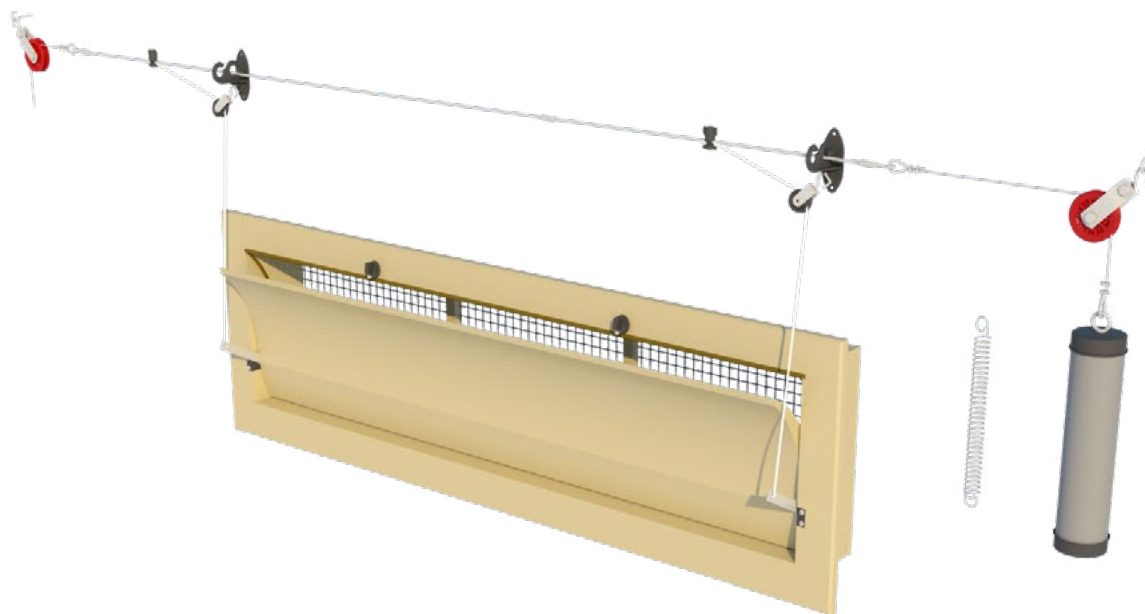

INFO

DATASHEET

ASSEMBLY

MOUNTING

WORKING

MAINTENANCE





6000-VFG DATASHEET



CAPACITY

Model	m ³ /h @ 10 Pa	m ³ /h @ 25 Pa	m ³ /h @ 40 Pa
6000-VFG	5800	8750	11600
	cfm @ 0.05 inH ₂ O	cfm @ 0.1 inH ₂ O	cfm @ 0.15 inH ₂ O
	3817	5746	6593

INFORMATION

Run	18 cm / 7.1 inch
Force	9 kg / 88 Newton
Number / pallet (1.65 x 1.05 x 2.40 m)	20
Weight / per inlet	10,8 kg / 23.8 lbs
Volume / per box	4

OPTIONAL ACCESSORIES

TPI-107	Wire mesh synthetic
TPI-207	Connection set
TPI-307 (*2)	Closing catch + spring
TPI-519 (*2)	Main cable support

AIR FLOW

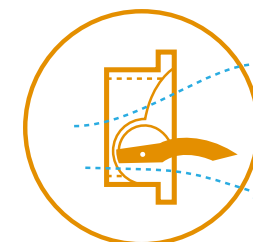
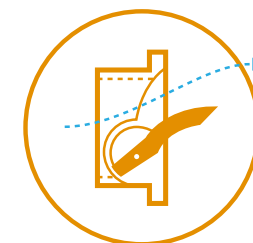

INFO

DATASHEET

ASSEMBLY

MOUNTING

WORKING

MAINTENANCE





TPI-204C

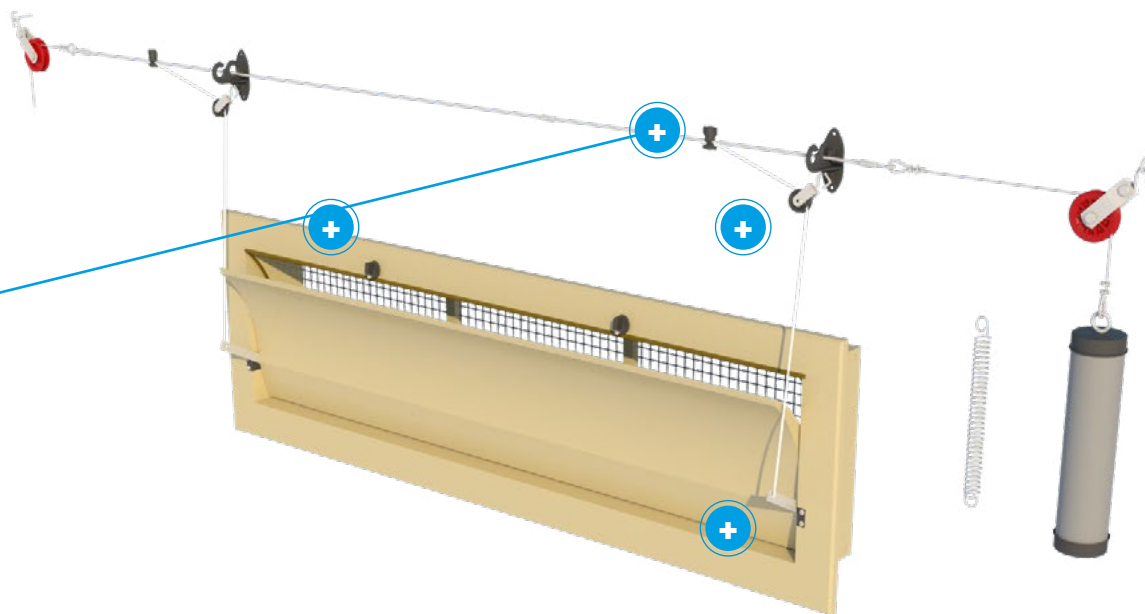

INFO

DATASHEET

ASSEMBLY

MOUNTING

WORKING

MAINTENANCE



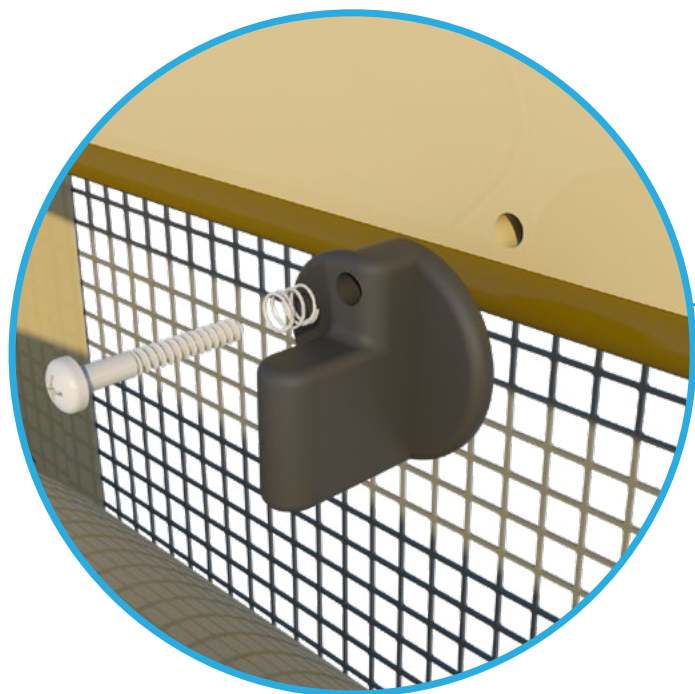

TPI-307

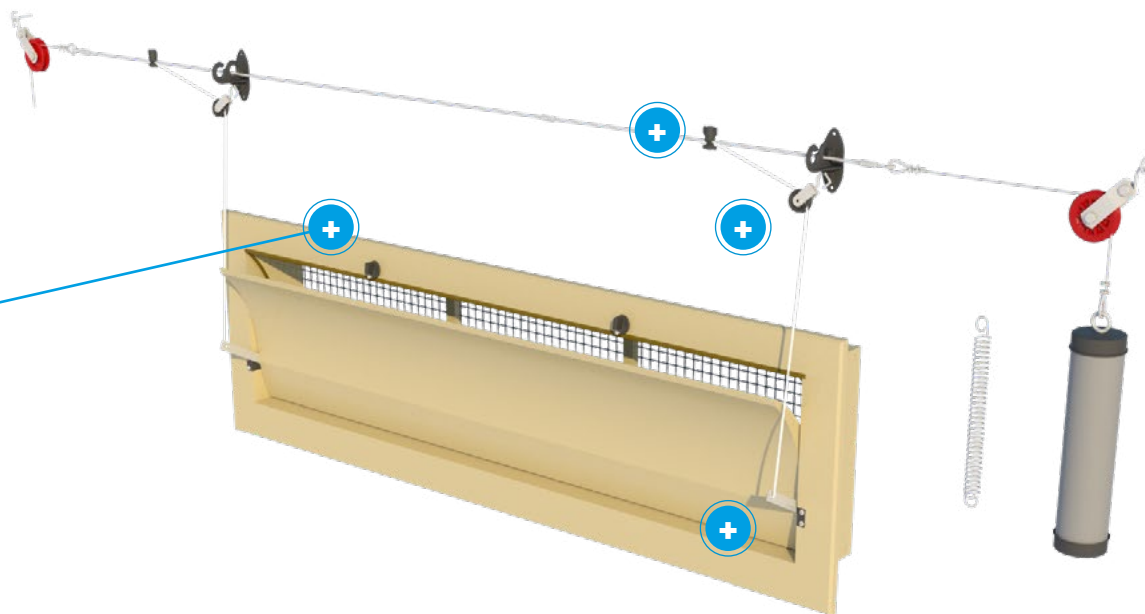

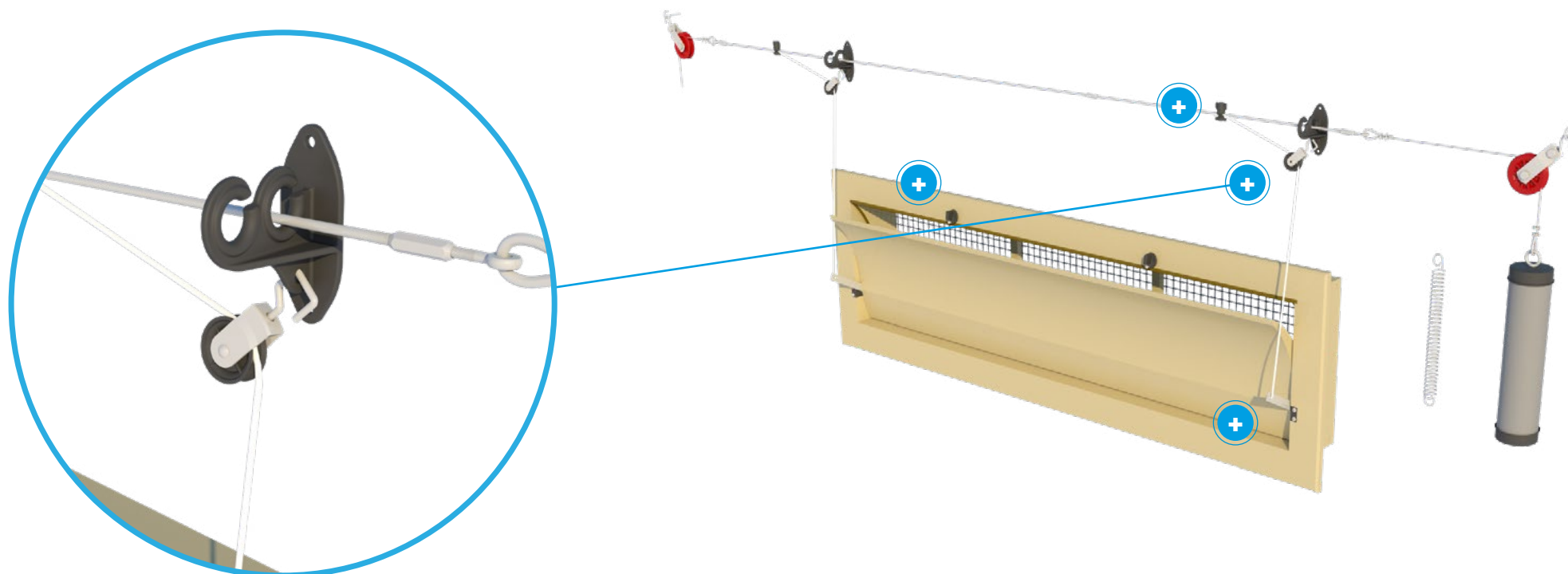

TPI-519 en TPI 408

INFO

DATASHEET

ASSEMBLY

MOUNTING

WORKING

MAINTENANCE



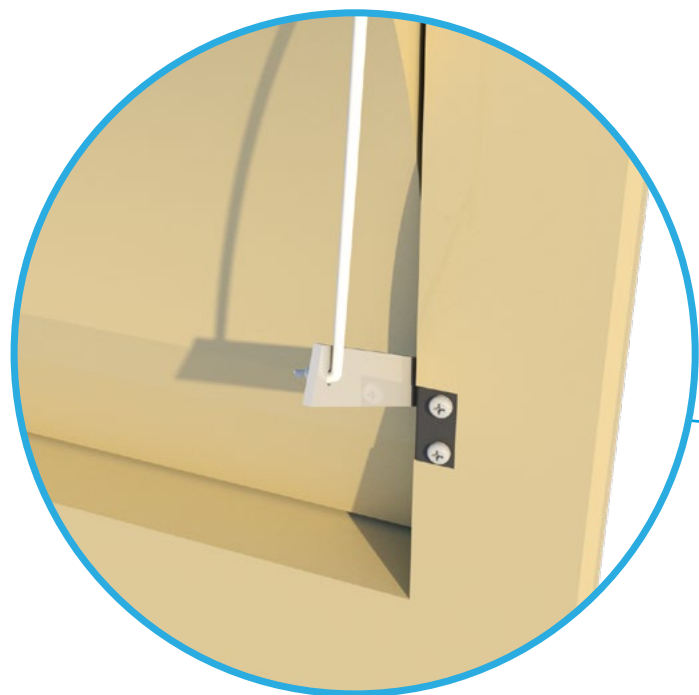

TPI-107

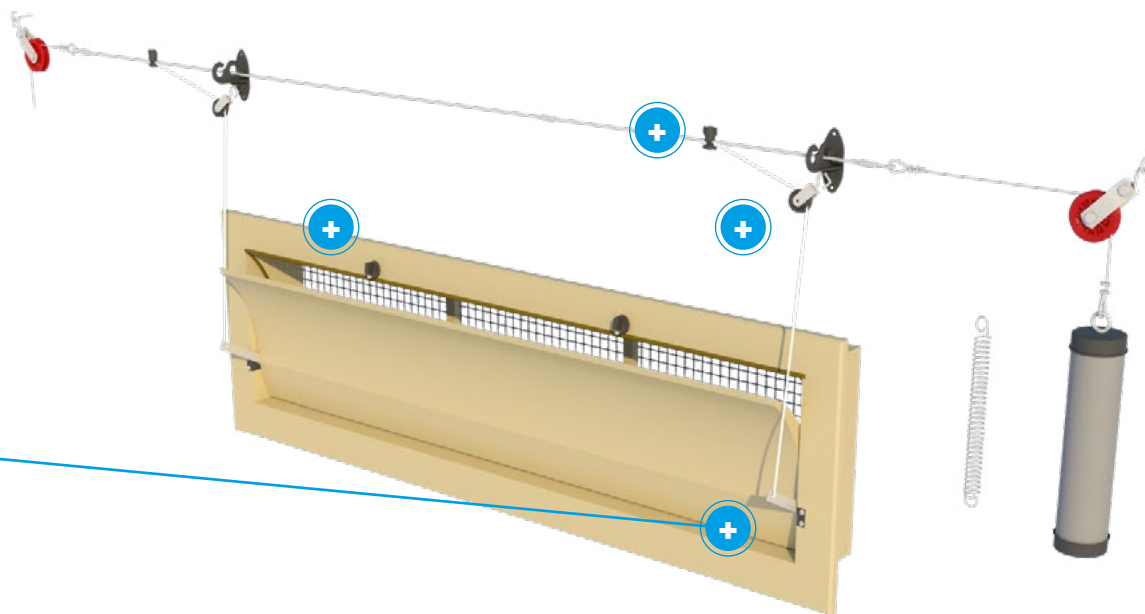

INFO

DATASHEET

ASSEMBLY

MOUNTING

WORKING

MAINTENANCE



All sizes are in cm and inches

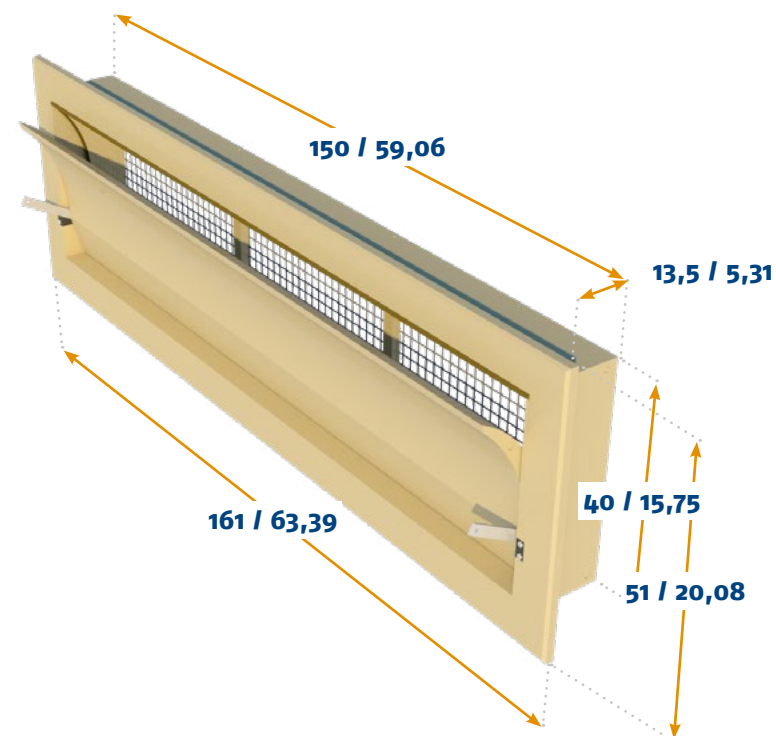
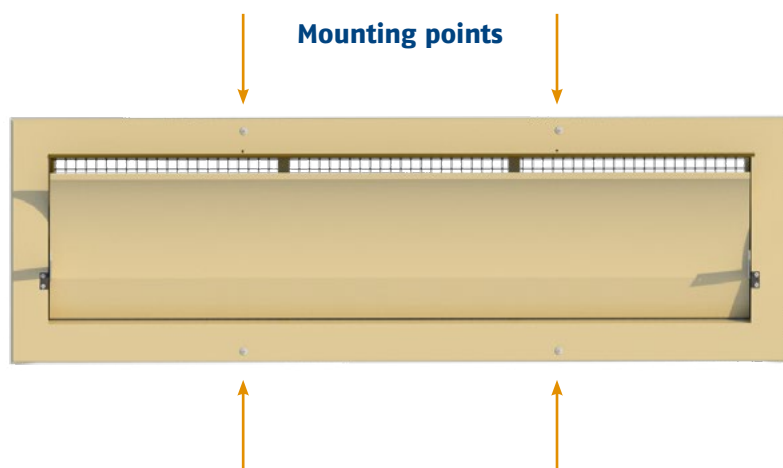

MOUNTING

Mounting type	Wall
Mounting hole size	152 cm / 59,84 inch x 42 cm / 16,54 inch

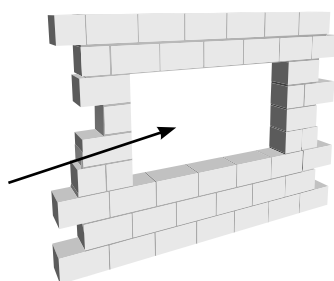

[INFO](#)

[DATASHEET](#)

[ASSEMBLY](#)

[MOUNTING](#)

[WORKING](#)

[MAINTENANCE](#)



AIR FLOW

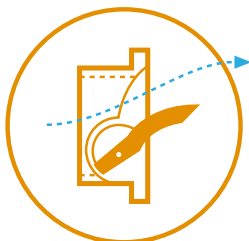

Middle hinged inlet

This middle hinged inlet is made to allow air to also flow underneath the inner flap after opening further than 35%. This helps to guide air downwards to the animals and provide a cooling effect during maximum ventilation.

Curved inner flap

This inlet is equipped with a curved inner flap. Curved flaps guide the air upwards during minimum ventilation, but also downwards after a certain point of opening. This is ideal for houses where air should be directed directly towards or over the animals during maximum ventilation.

Working with end-weights or springs

We offer two products which can be used to keep tension on the main cable. A PVC cylinder which can be filled with concrete or sand to act as end-weight, or a spring that holds tension on the cable.

Balanced set-up

When placing the motor winch or actuator we normally suggest to divide the inlets in two groups. It is preferable to place the winch or actuator in the middle to equally divide the forces on the main cable.

(see ventilation concepts page for an example)

Use of closing catches

The closing catch on the inlet can be used to permanently close inlets for example during pre-heating. The closing catches can also be used to close certain inlets while continuing to use others. In that case the used inlets can be opened a bit further. In colder climates this can help to offer better resistance to freezing effects.

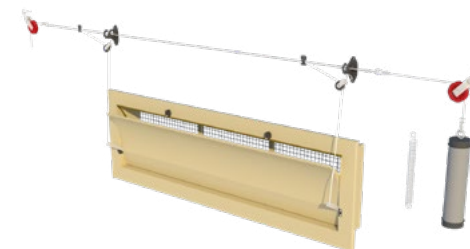

INFO

DATASHEET

ASSEMBLY

MOUNTING

WORKING

MAINTENANCE



6000-VFG-C

This inlet is by far our biggest wall inlet in the familiar rectangular shape. This inlet is controlled by two plastic arms to offer maximum control and precision. This inlet is designed with the option to combine multiple inlets into a complete tunnel unit. This version is equipped with a curved inner valve which also guides air down after being opened over 35%.

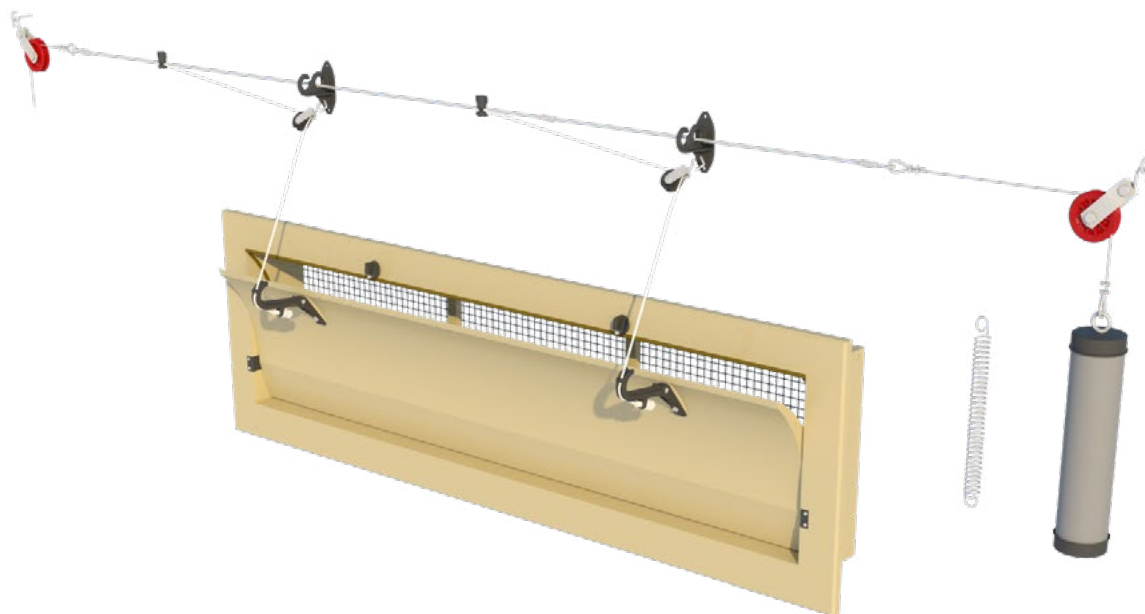

INFO

DATASHEET

ASSEMBLY

MOUNTING

WORKING

MAINTENANCE





6000-VFG-C DATASHEET



CAPACITY

Model	m ³ /h @ 10 Pa	m ³ /h @ 25 Pa	m ³ /h @ 40 Pa
6000-VFG-C	5800	8750	11600
	cfm @ 0.05 inH ₂ O	cfm @ 0.1 inH ₂ O	cfm @ 0.15 inH ₂ O
	3817	5746	6593

INFORMATION

Run	47 cm / 18.5 inch
Force	3,5 kg / 34.3 Newton
Number / pallet (1.65 x 1.05 x 2.40 m)	20
Weight / per inlet	10,8 kg / 23.8 lbs
Volume / per box	4
Arm position	3

OPTIONAL ACCESSORIES

TPI-107	Wire mesh synthetic
TPI-207	Connection set
TPI-307 (*2)	Closing catch + spring
TPI-519 (*2)	Main cable support

AIR FLOW

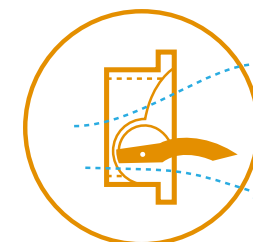
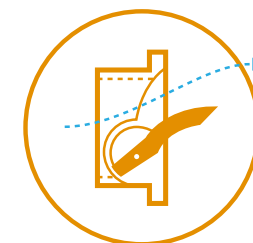
[INFO](#)[DATASHEET](#)[ASSEMBLY](#)[MOUNTING](#)[WORKING](#)[MAINTENANCE](#)

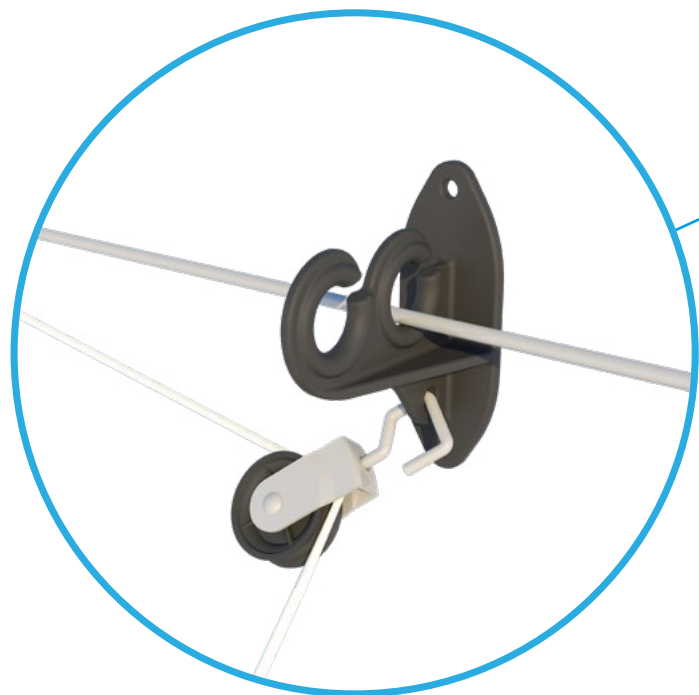

TPI-408/TPI-519

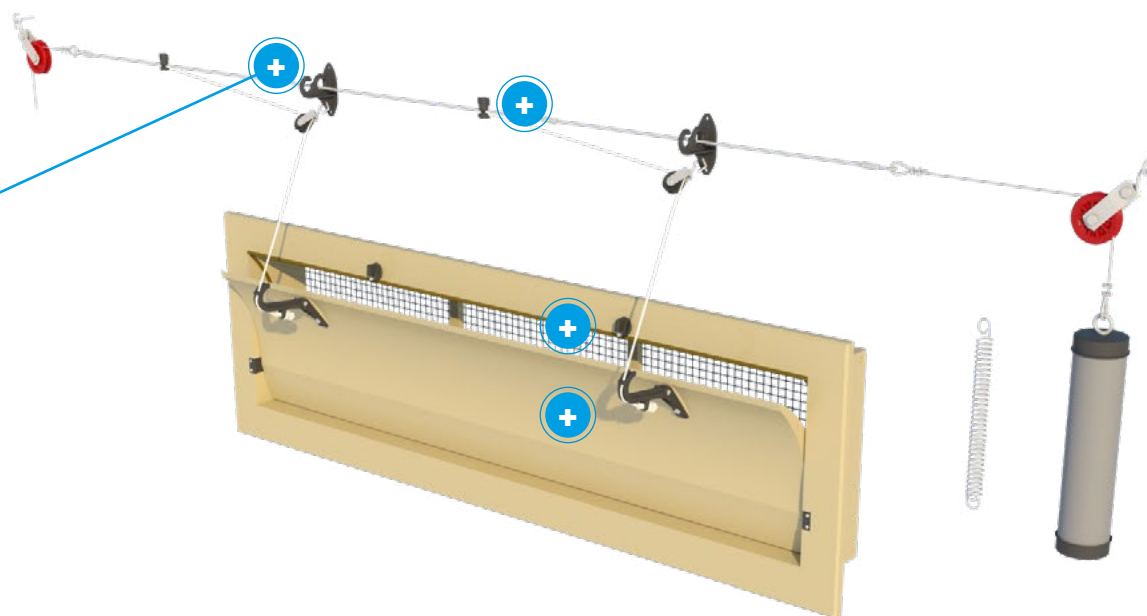



TPI-204C

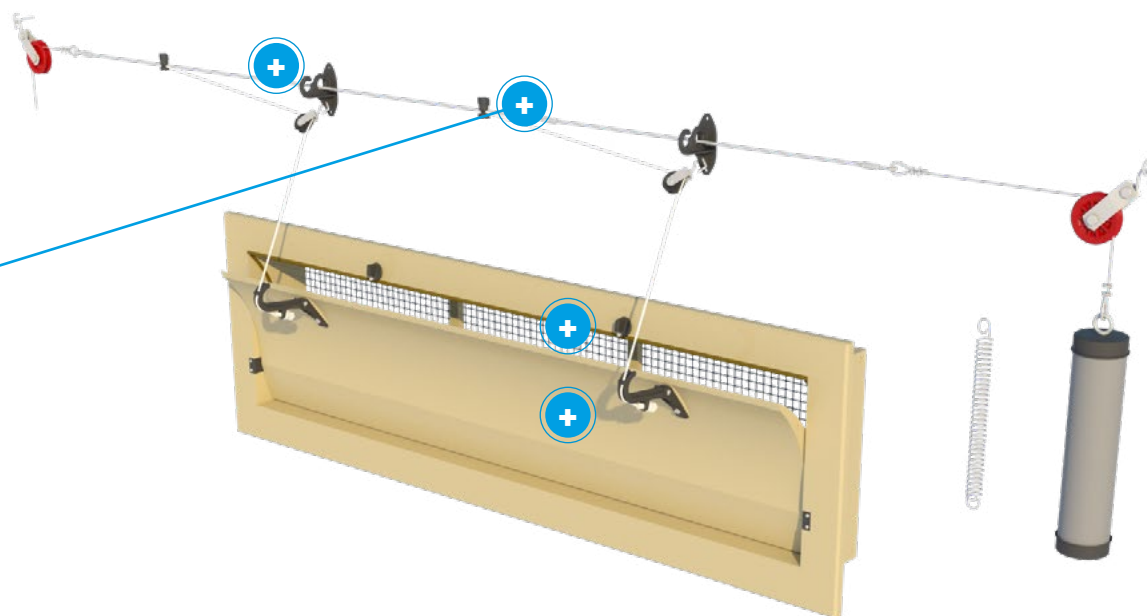

INFO

DATASHEET

ASSEMBLY

MOUNTING

WORKING

MAINTENANCE



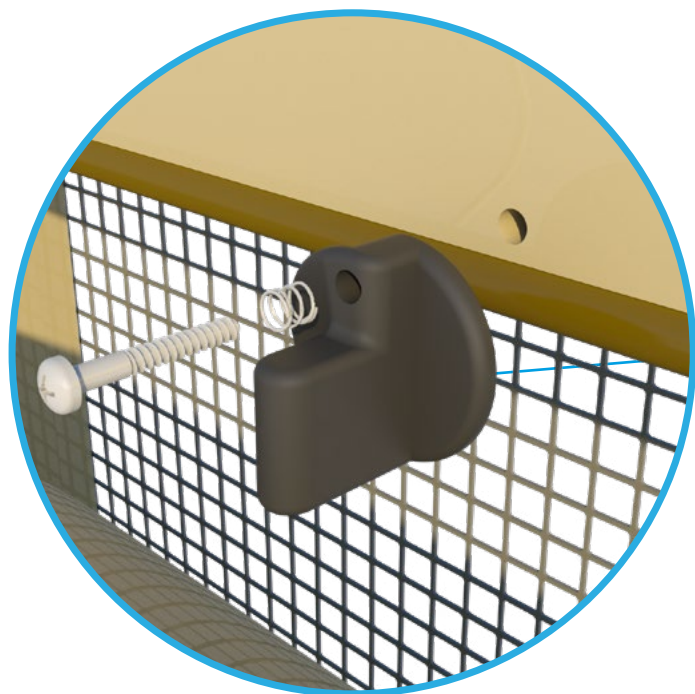

TPI-307

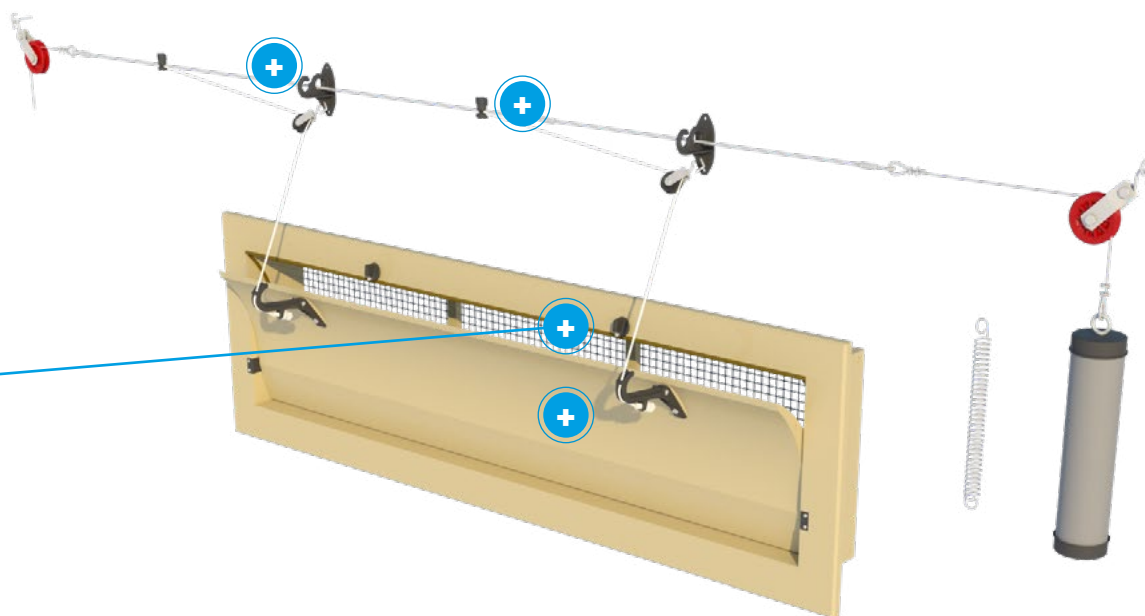

[INFO](#)

[DATASHEET](#)

[ASSEMBLY](#)

[MOUNTING](#)

[WORKING](#)

[MAINTENANCE](#)



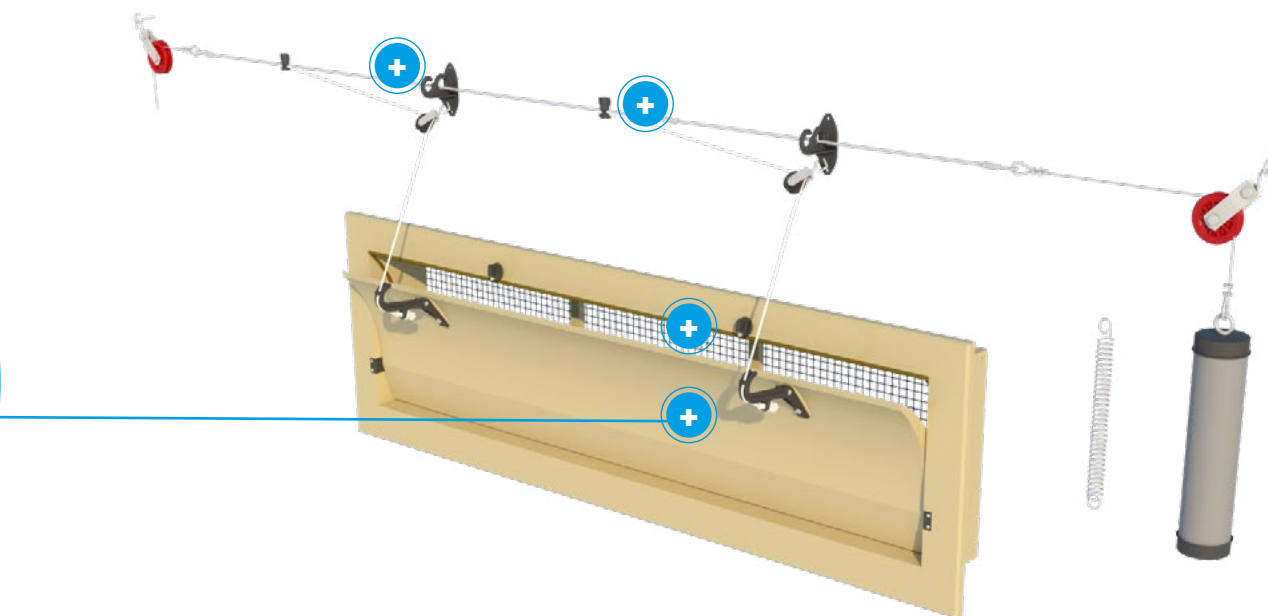
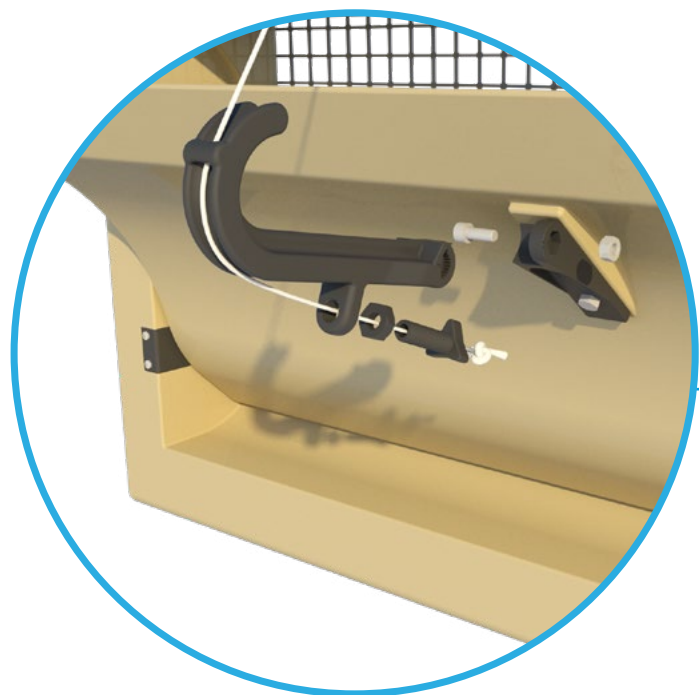

All sizes are in cm and inches

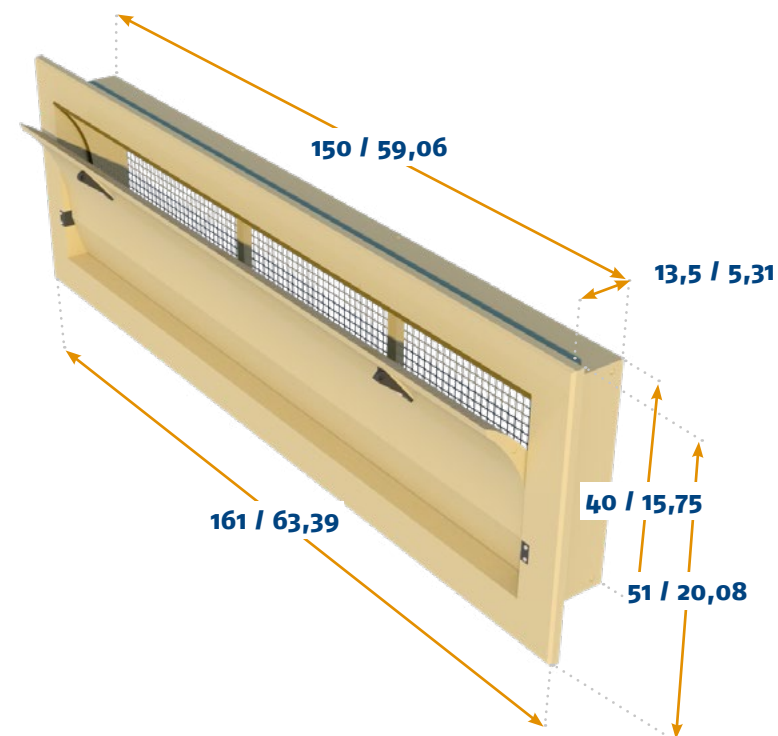
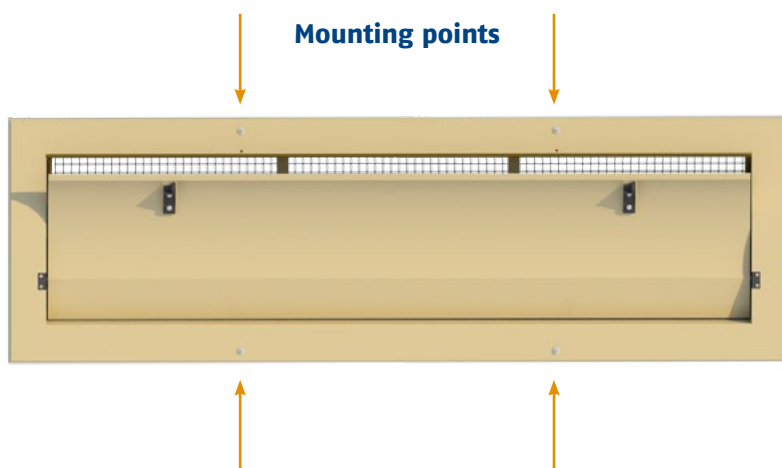

MOUNTING

Mounting type	Wall
Mounting hole size	152 cm / 59,84 inch x 42 cm / 16,54 inch

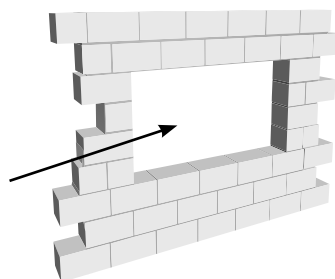

[INFO](#)

[DATASHEET](#)

[ASSEMBLY](#)

[MOUNTING](#)

[WORKING](#)

[MAINTENANCE](#)



AIR FLOW

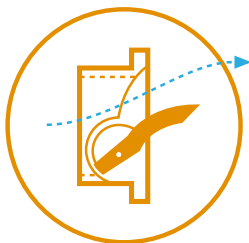

Middle hinged inlet

This middle hinged inlet is made to allow air to also flow underneath the inner flap after opening further than 35%. This helps to guide air downwards to the animals and provide a cooling effect during maximum ventilation.

Curved inner flap

This inlet is equipped with a curved inner flap. Curved flaps guide the air upwards during minimum ventilation, but also downwards after a certain point of opening. This is ideal for houses where air should be directed directly towards or over the animals during maximum ventilation.

Working with end-weights or springs

We offer two products which can be used to keep tension on the main cable. A PVC cylinder which can be filled with concrete or sand to act as end-weight, or a spring that holds tension on the cable.

Balanced set-up

When placing the motor winch or actuator we normally suggest to divide the inlets in two groups. It is preferable to place the winch or actuator in the middle to equally divide the forces on the main cable.

(see ventilation concepts page for an example)

Use of closing catches

The closing catch on the inlet can be used to permanently close inlets for example during pre-heating. The closing catches can also be used to close certain inlets while continuing to use others. In that case the used inlets can be opened a bit further. In colder climates this can help to offer better resistance to freezing effects.

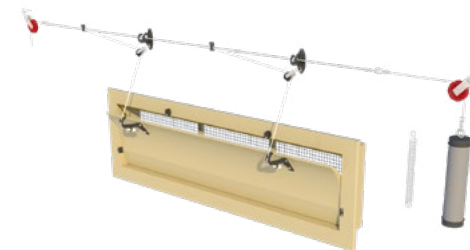
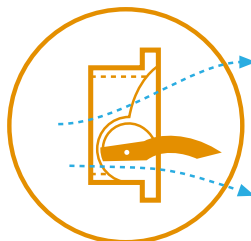

INFO

DATASHEET

ASSEMBLY

MOUNTING

WORKING

MAINTENANCE



6000-VFR

This inlet is by far our biggest wall inlet in the familiar rectangular shape. This inlet is controlled by two arms to offer maximum control and precision. This inlet is designed with the option to combine multiple inlets into a complete tunnel unit. This version is equipped with a straight inner valve that guides the air upwards during minimum ventilation. After opening further than 35% the air will also flow underneath the inner valve.

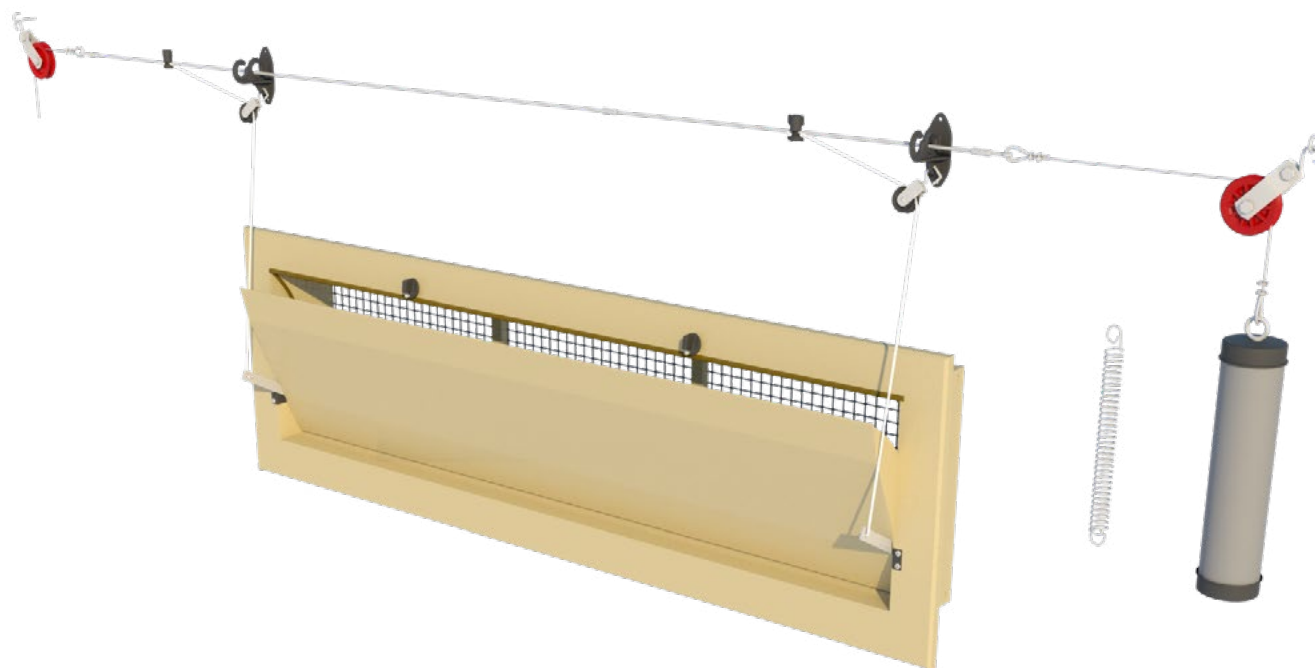

INFO

DATASHEET

ASSEMBLY

MOUNTING

WORKING

MAINTENANCE





6000-VFR DATASHEET



CAPACITY

Model	m ³ /h @ 10 Pa	m ³ /h @ 25 Pa	m ³ /h @ 40 Pa
6000-VFR-C	5800	8750	11600
	cfm @ 0.05 inH ₂ O	cfm @ 0.1 inH ₂ O	cfm @ 0.15 inH ₂ O
	3817	5746	6593

INFORMATION

Run	17 cm / 6.7 inch
Force	9 kg / 88 Newton
Number / pallet (1.65 x 1.05 x 2.40 m)	20
Weight / per inlet	10,8 kg / 23.8 lbs
Volume / per box	4

OPTIONAL ACCESSORIES

TPI-107	Wire mesh synthetic
TPI-207	Connection set
TPI-307 (*2)	Closing catch + spring
TPI-519 (*2)	Main cable support

AIR FLOW

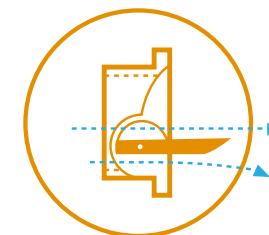
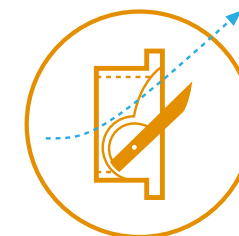

INFO

DATASHEET

ASSEMBLY

MOUNTING

WORKING

MAINTENANCE



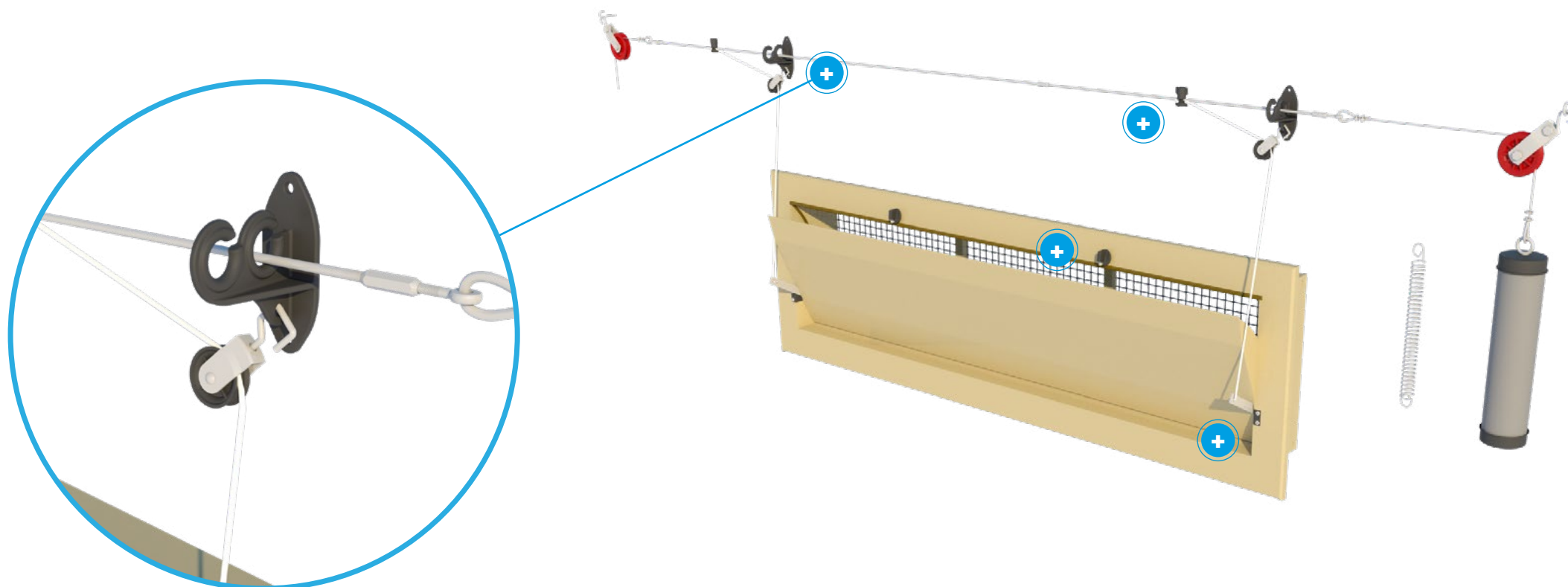

TPI-408/TPI-519

INFO

DATASHEET

ASSEMBLY

MOUNTING

WORKING

MAINTENANCE





TPI-207

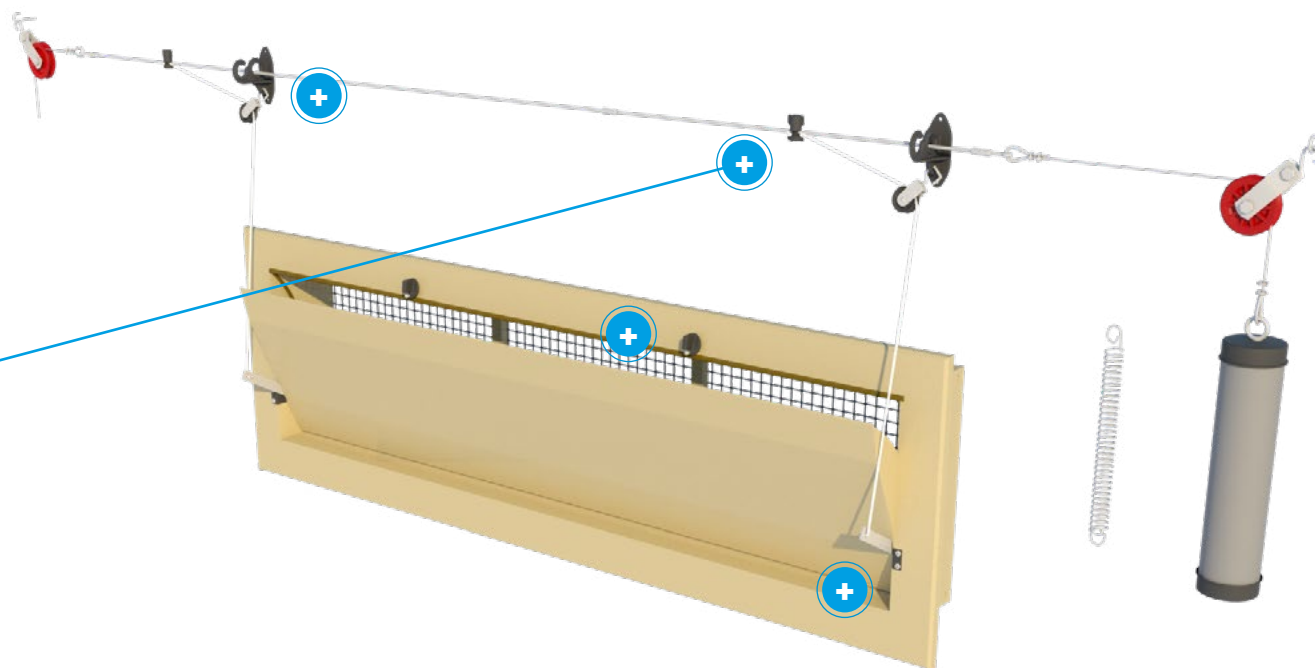

INFO

DATASHEET

ASSEMBLY

MOUNTING

WORKING

MAINTENANCE



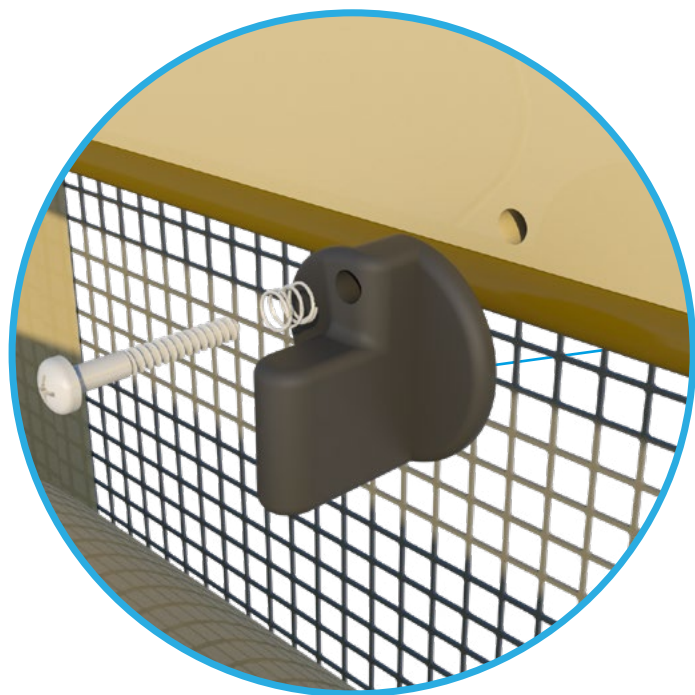

TPI-307

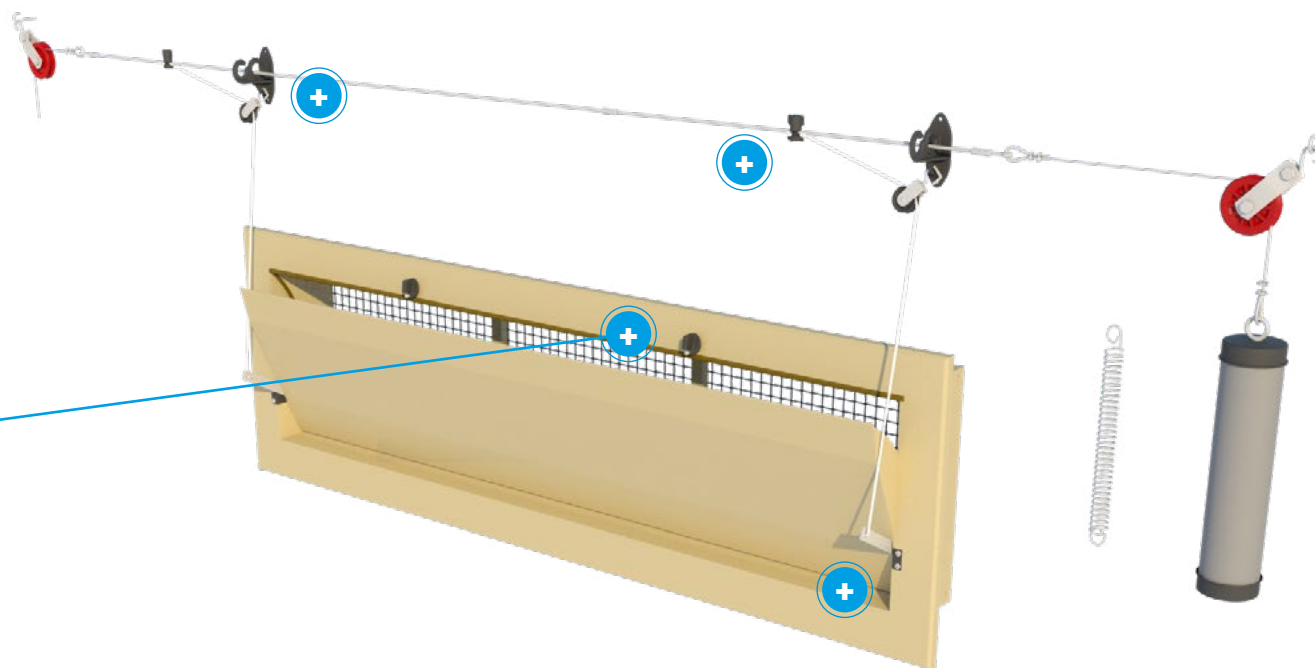

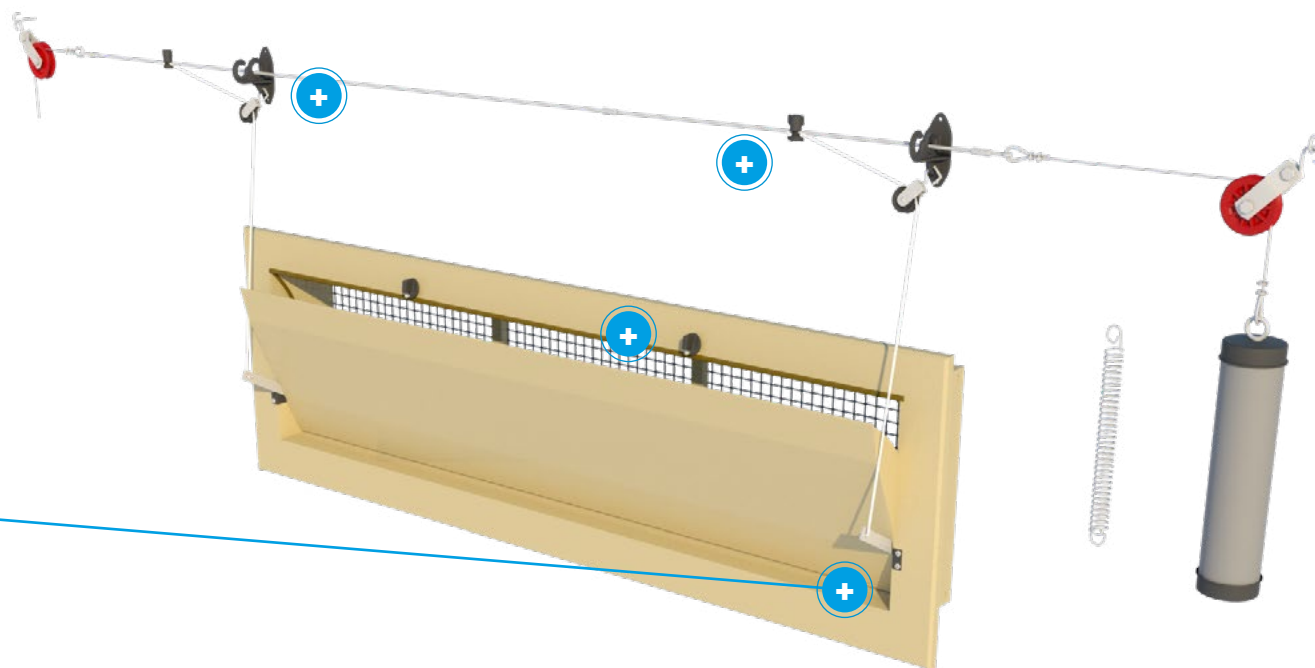
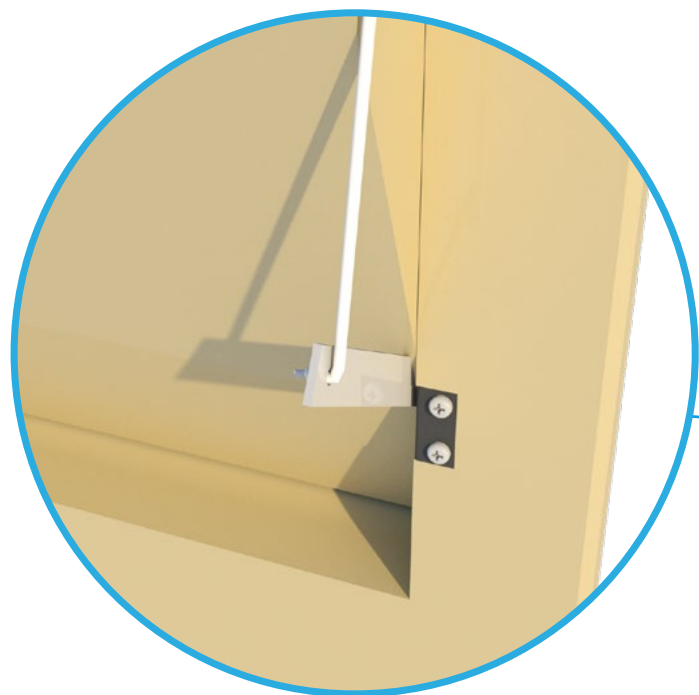

INFO

DATASHEET

ASSEMBLY

MOUNTING

WORKING

MAINTENANCE



All sizes are in cm and inches

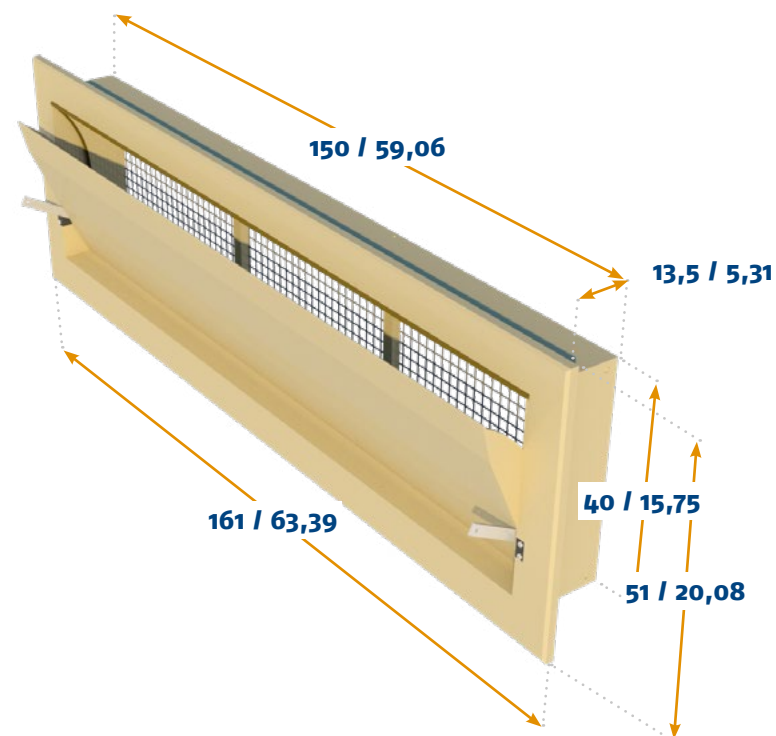
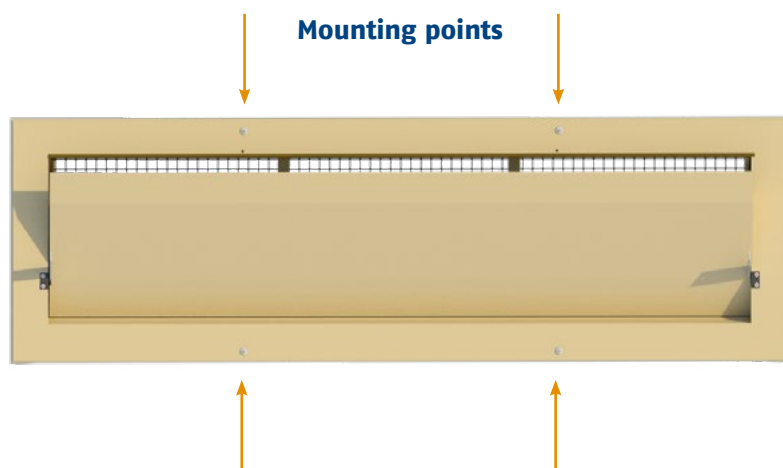

MOUNTING

Mounting type	Wall
Mounting hole size	152 cm / 59,84 inch x 42 cm / 16,54 inch

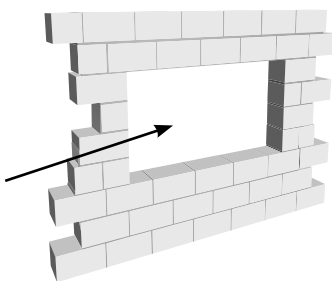

[INFO](#)

[DATASHEET](#)

[ASSEMBLY](#)

[MOUNTING](#)

[WORKING](#)

[MAINTENANCE](#)



AIR FLOW

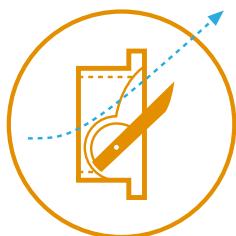

Middle hinged inlet

This middle hinged inlet is made to allow air to also flow underneath the inner flap after opening further then 35%. This helps to guide air downwards to the animals and provide a cooling effect during maximum ventilation.

Straight inner flap

This inlet is equipped with a straight inner flap. Straight flaps guide air in a straight upwards or horizontal direction, never downwards. This is ideal for houses where air should not be directed directly towards or over the animals during maximum ventilation.

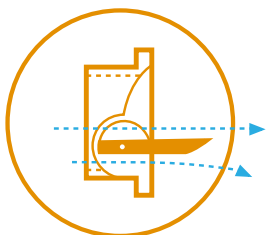

Working with end-weights or springs

We offer two products which can be used to keep tension on the main cable. A PVC cylinder which can be filled with concrete or sand to act as end-weight, or a spring that holds tension on the cable.

Balanced set-up

When placing the motor winch or actuator we normally suggest to divide the inlets in two groups. It is preferable to place the winch or actuator in the middle to equally divide the forces on the main cable.

(see ventilation concepts page for an example)

Use of closing catches

The closing catch on the inlet can be used to permanently close inlets for example during pre-heating. The closing catches can also be used to close certain inlets while continuing to use others. In that case the used inlets can be opened a bit further. In colder climates this can help to offer better resistance to freezing effects.

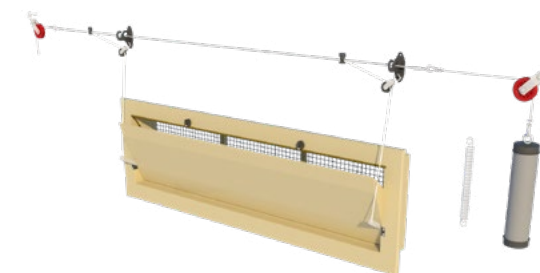
[INFO](#)
[DATASHEET](#)
[ASSEMBLY](#)
[MOUNTING](#)
[WORKING](#)
[MAINTENANCE](#)

6000-VFR-C

This inlet is by far our biggest wall inlet in the familiar rectangular shape. This inlet is controlled by two plastic arms to offer maximum control and precision. This inlet is designed with the option to combine multiple inlets into a complete tunnel unit. This version is equipped with a straight inner valve that guides the air upwards during minimum ventilation. After opening further than 35% the air will also flow underneath the inner valve.

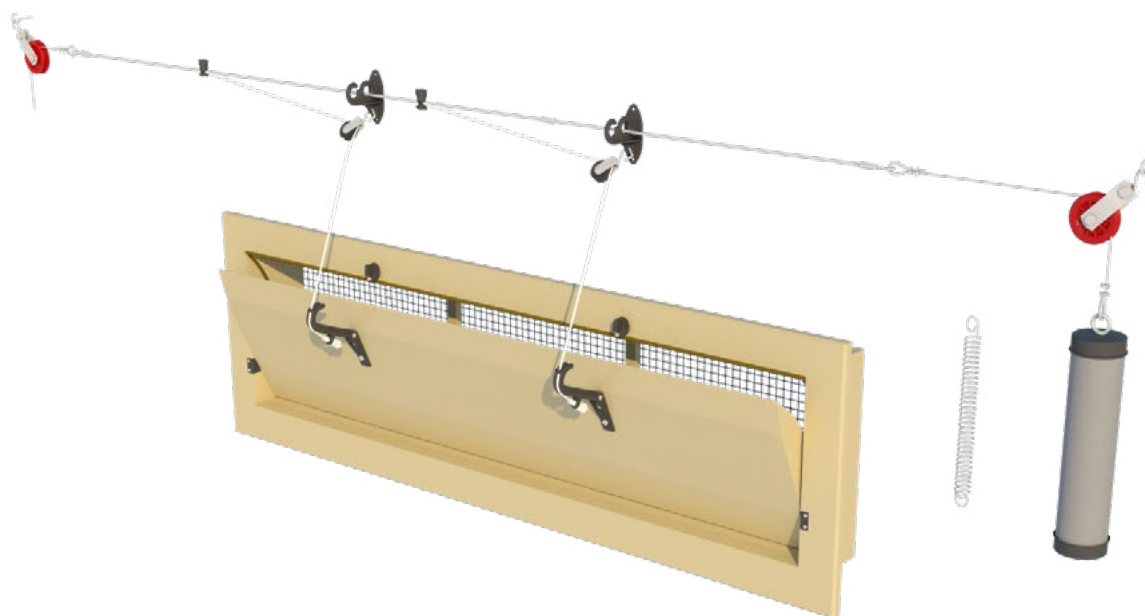

INFO

DATASHEET

ASSEMBLY

MOUNTING

WORKING

MAINTENANCE





6000-VFR-C DATASHEET



CAPACITY

Model	m ³ /h @ 10 Pa	m ³ /h @ 25 Pa	m ³ /h @ 40 Pa
6000-VFR-C	5800	8750	11600
	cfm @ 0.05 inH ₂ O	cfm @ 0.1 inH ₂ O	cfm @ 0.15 inH ₂ O
	3817	5746	6593

INFORMATION

Run	42 cm / 16.5 inch
Force	3,5 kg / 34.3 Newton
Number / pallet (1.65 x 1.05 x 2.40 m)	20
Weight / per inlet	10,8 kg / 23.8 lbs
Volume / per box	4
Arm position	3

OPTIONAL ACCESSORIES

TPI-107	Wire mesh synthetic
TPI-207	Connection set
TPI-307 (*2)	Closing catch + spring
TPI-519 (*2)	Main cable support

AIR FLOW

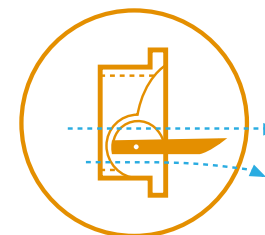
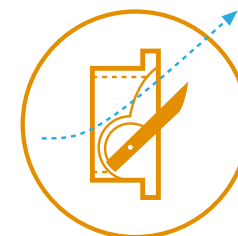

INFO

DATASHEET

ASSEMBLY

MOUNTING

WORKING

MAINTENANCE



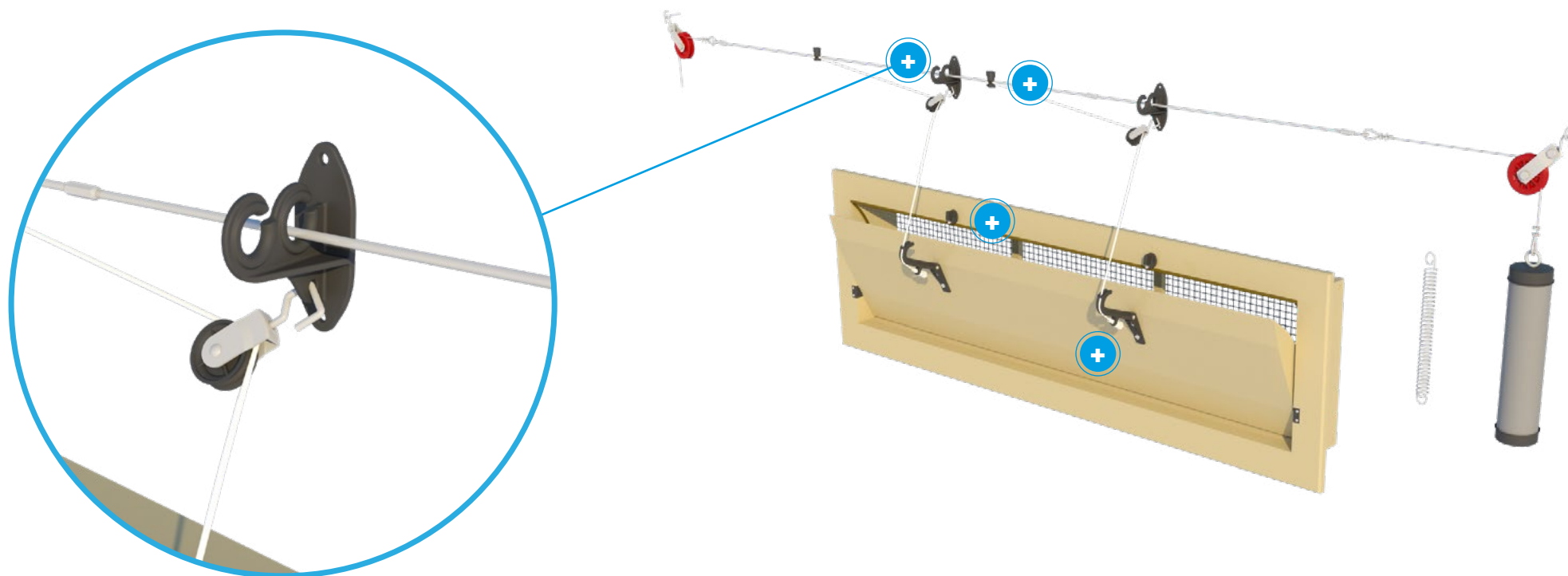

TPI-408/TPI-519

INFO

DATASHEET

ASSEMBLY

MOUNTING

WORKING

MAINTENANCE





TPI-204C

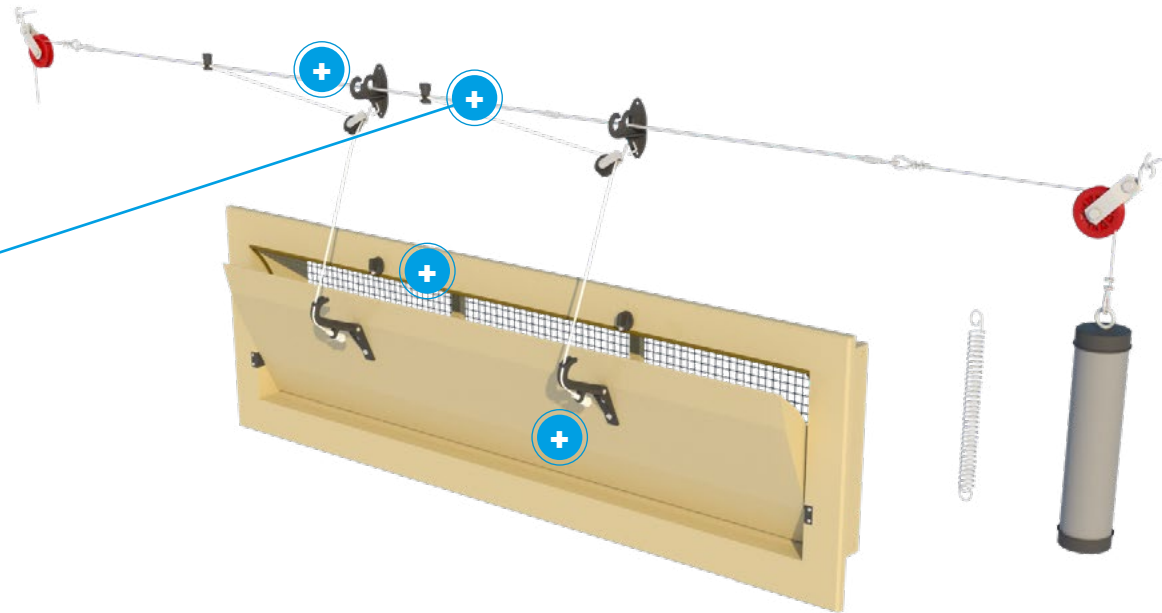

INFO

DATASHEET

ASSEMBLY

MOUNTING

WORKING

MAINTENANCE



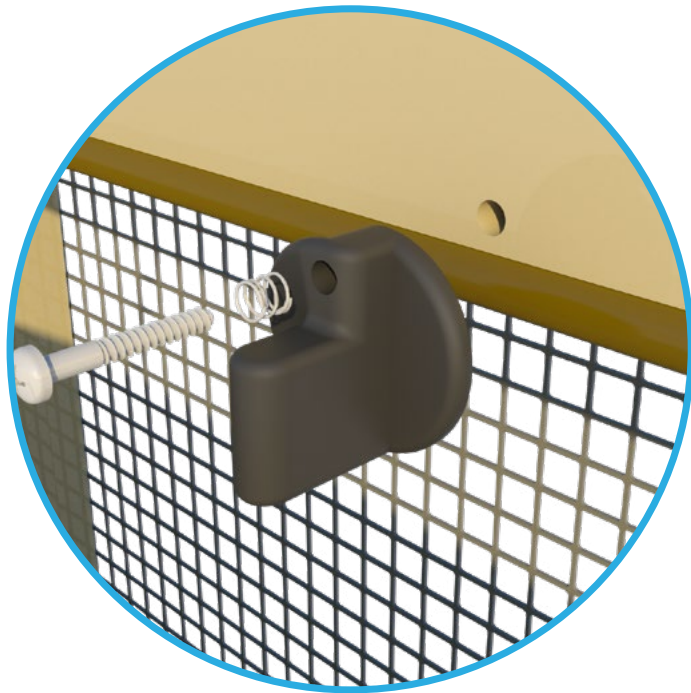

TPI-307

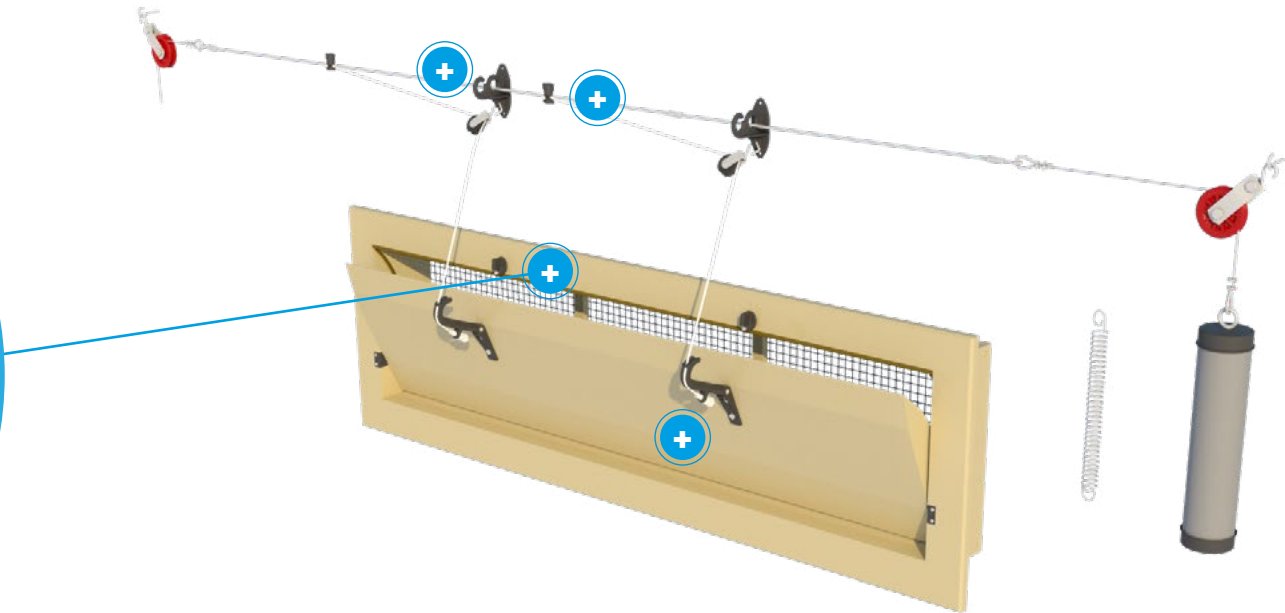

[INFO](#)

[DATASHEET](#)

[ASSEMBLY](#)

[MOUNTING](#)

[WORKING](#)

[MAINTENANCE](#)



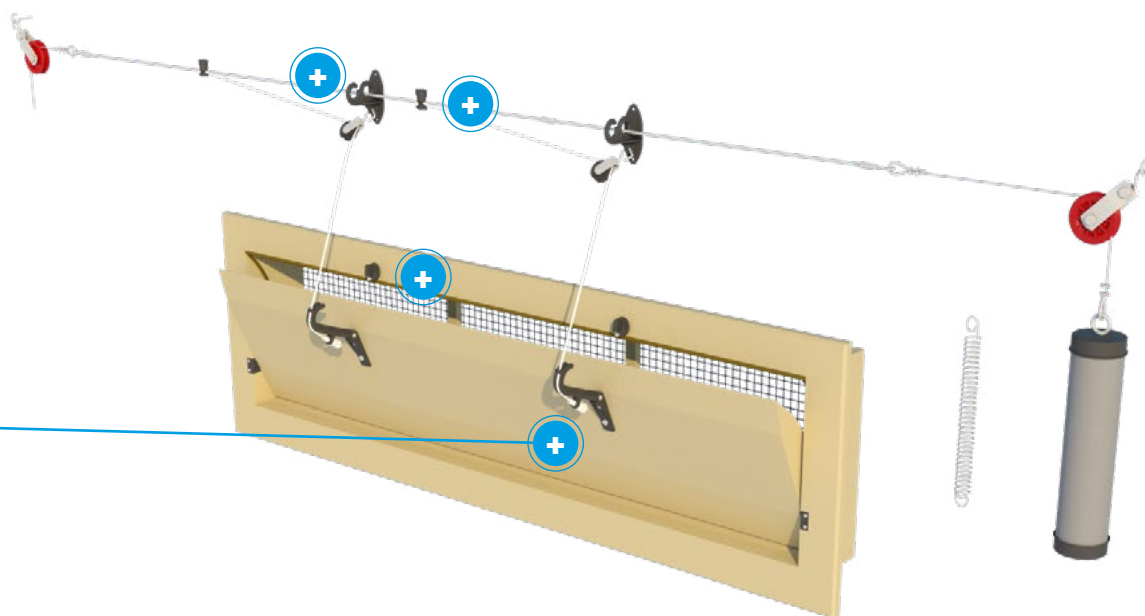
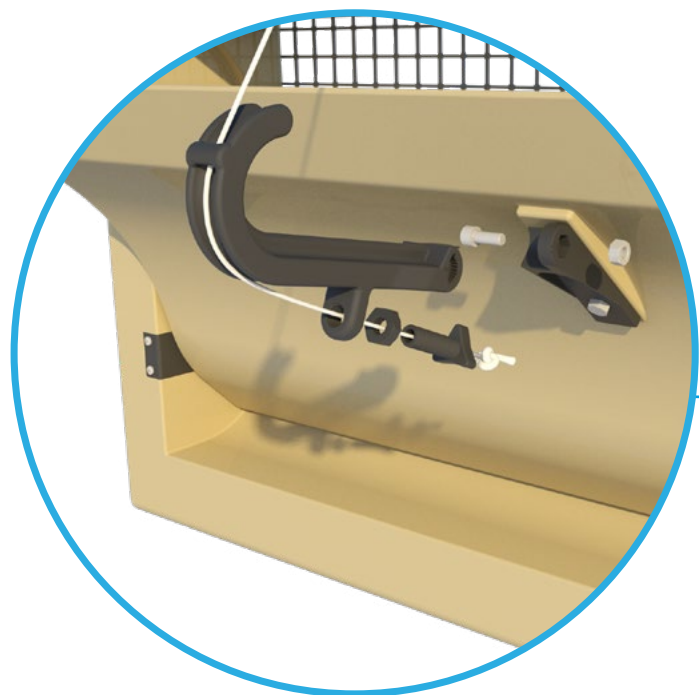

INFO

DATASHEET

ASSEMBLY

MOUNTING

WORKING

MAINTENANCE



All sizes are in cm and inches

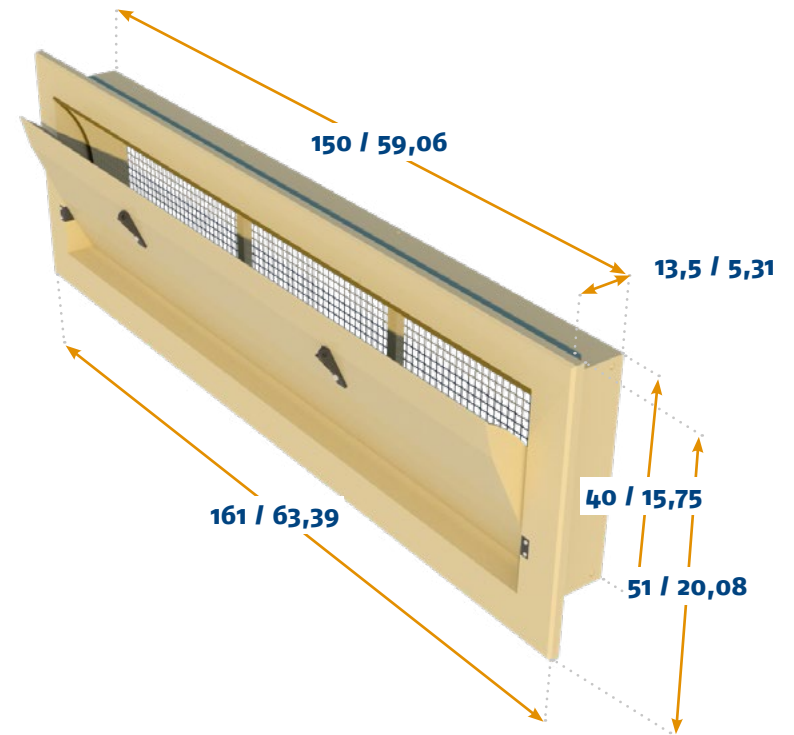
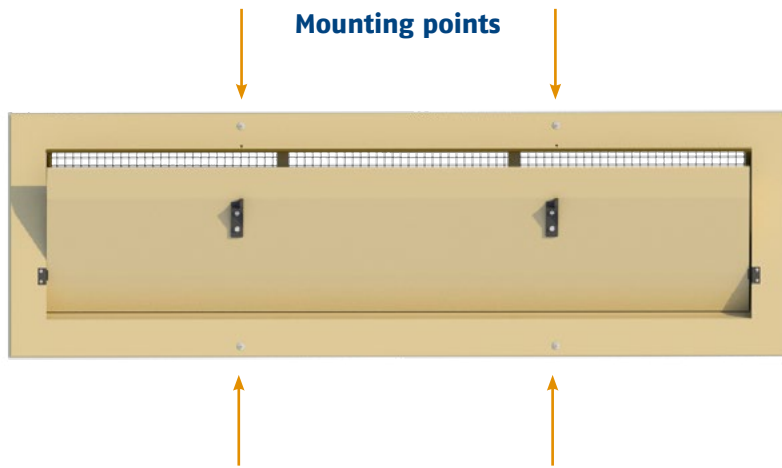

MOUNTING

Mounting type	Wall
Mounting hole size	152 cm / 59,84 inch x 42 cm / 16,54 inch

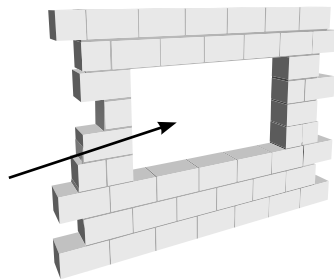

[INFO](#)

[DATASHEET](#)

[ASSEMBLY](#)

[MOUNTING](#)

[WORKING](#)

[MAINTENANCE](#)



AIR FLOW

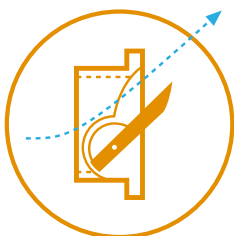

Middle hinged inlet

This middle hinged inlet is made to allow air to also flow underneath the inner flap after opening further than 35%. This helps to guide air downwards to the animals and provide a cooling effect during maximum ventilation.

Straight inner flap

This inlet is equipped with a straight inner flap. Straight flaps guide air in a straight upwards or horizontal direction, never downwards. This is ideal for houses where air should not be directed directly towards or over the animals during maximum ventilation.

Working with end-weights or springs

We offer two products which can be used to keep tension on the main cable. A PVC cylinder which can be filled with concrete or sand to act as end-weight, or a spring that holds tension on the cable.

Balanced set-up

When placing the motor winch or actuator we normally suggest to divide the inlets in two groups. It is preferable to place the winch or actuator in the middle to equally divide the forces on the main cable.

(see ventilation concepts page for an example)

Use of closing catches

The closing catch on the inlet can be used to permanently close inlets for example during pre-heating. The closing catches can also be used to close certain inlets while continuing to use others. In that case the used inlets can be opened a bit further. In colder climates this can help to offer better resistance to freezing effects.

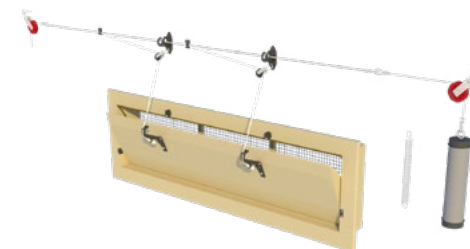

INFO

DATASHEET

ASSEMBLY

MOUNTING

WORKING

MAINTENANCE



6000-VFG-2

This tunnel unit is built up out of two single 6000-VFG inlets. This version is equipped with a curved inner valve that guides the air upwards during minimum ventilation. After opening further than 35% the air will also flow underneath the inner valve. This unit is controlled by side arms that connect the inner valves.



INFO

DATASHEET

ASSEMBLY

MOUNTING

WORKING

MAINTENANCE





6000-VFG-2 DATASHEET



CAPACITY

Model	m ³ /h @ 10 Pa	m ³ /h @ 25 Pa	m ³ /h @ 40 Pa
6000-VFG-2	11600	17500	23200
	cfm @ 0.05 inH ₂ O	cfm @ 0.1 inH ₂ O	cfm @ 0.15 inH ₂ O
	7633	11493	13186

INFORMATION

Run	18 cm / 7.1 inch
Force	18 kg / 176 Newton
Number / pallet (1.65 x 0.95 x 2.40 m)	10
Weight / per inlet	21,3 kg / 47 lbs
Volume / per box	2

OPTIONAL ACCESSORIES

TPI-107 (*2)	Wire mesh synthetic
TPI-208a	Connection set
TPI-307 (*4)	Closing catch + spring
TPI-519 (*2)	Main cable support

AIR FLOW

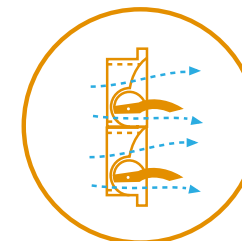
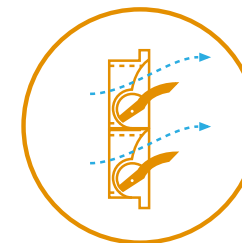

INFO

DATASHEET

ASSEMBLY

MOUNTING

WORKING

MAINTENANCE



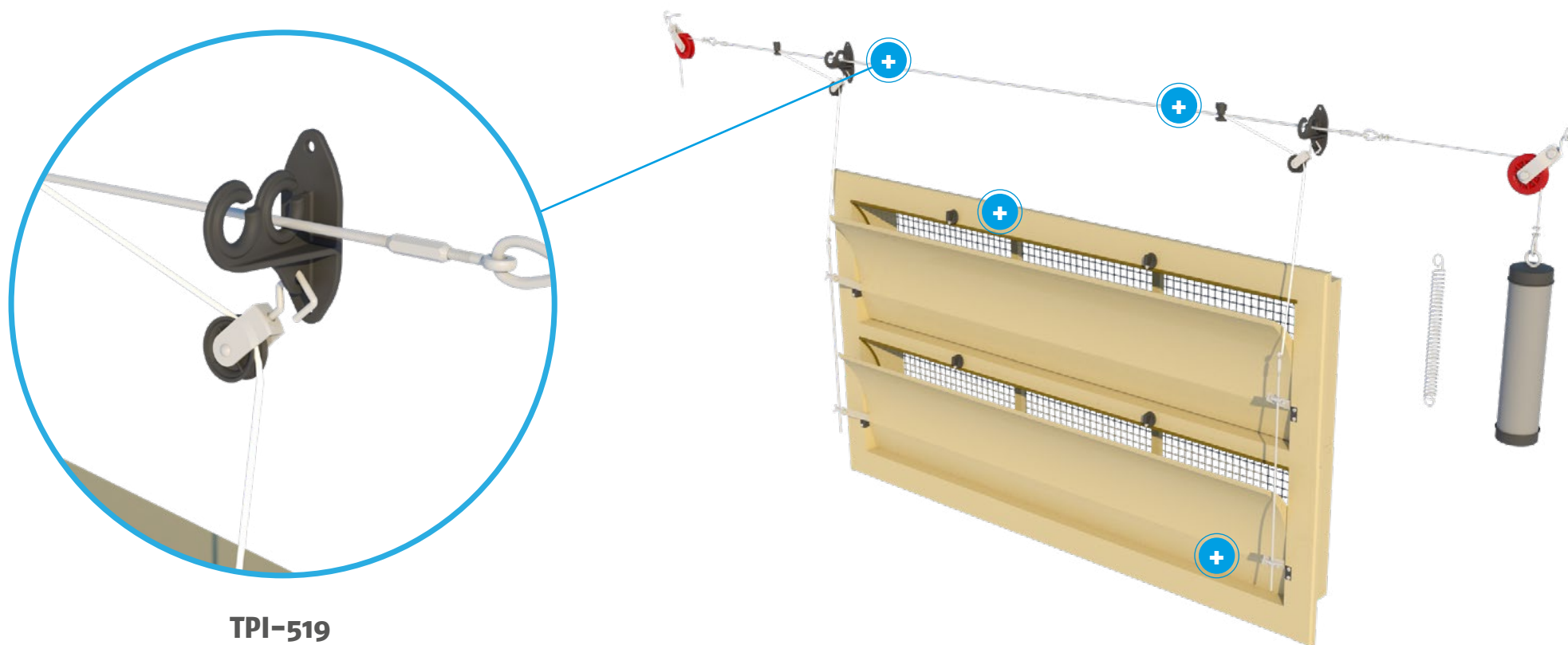

[INFO](#)

[DATASHEET](#)

[ASSEMBLY](#)

[MOUNTING](#)

[WORKING](#)

[MAINTENANCE](#)



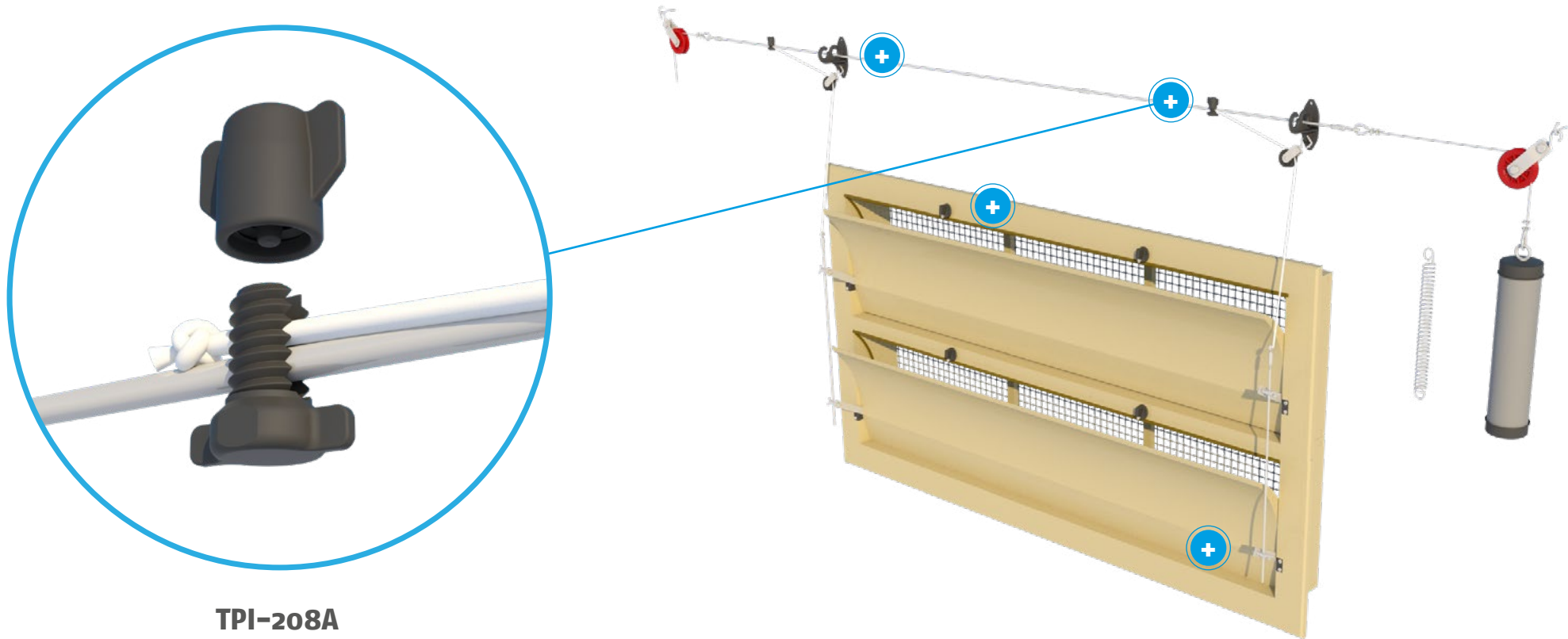

TPI-208A

INFO

DATASHEET

ASSEMBLY

MOUNTING

WORKING

MAINTENANCE



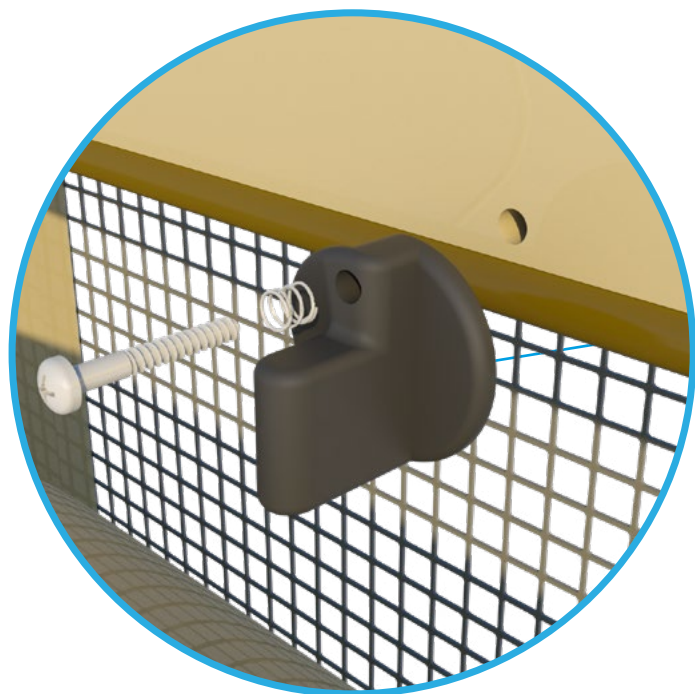

TPI-307

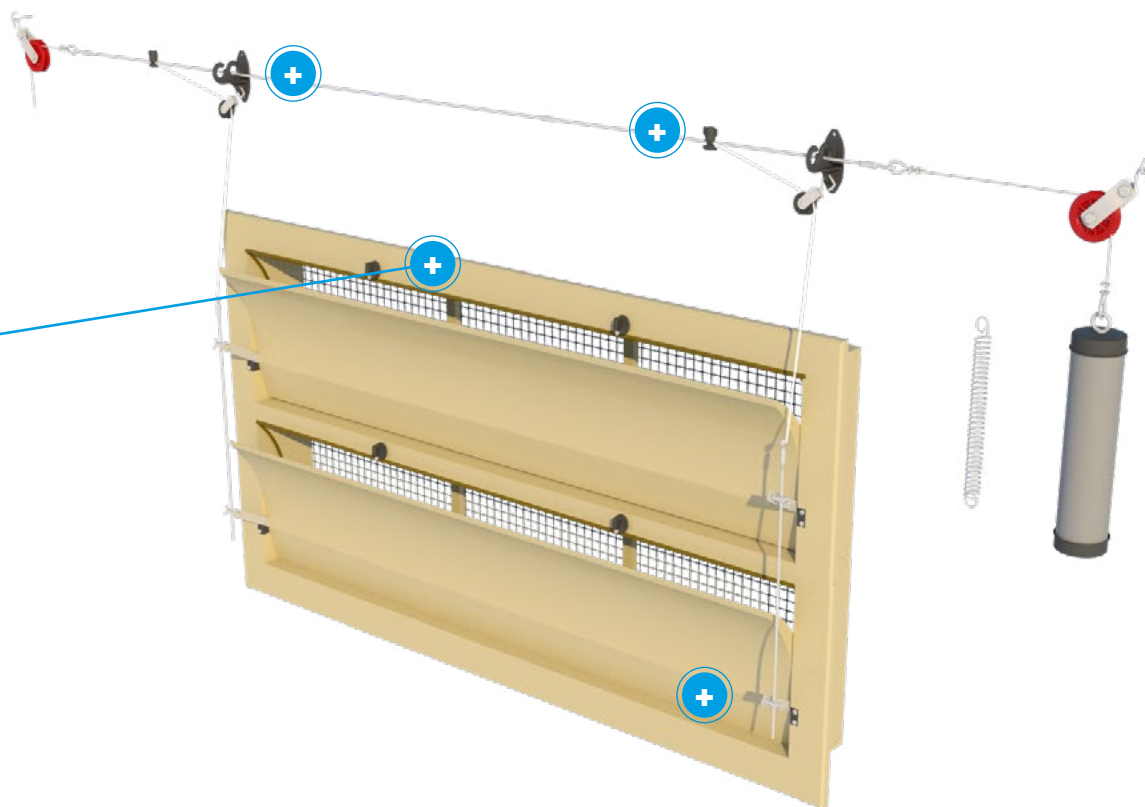

INFO

DATASHEET

ASSEMBLY

MOUNTING

WORKING

MAINTENANCE



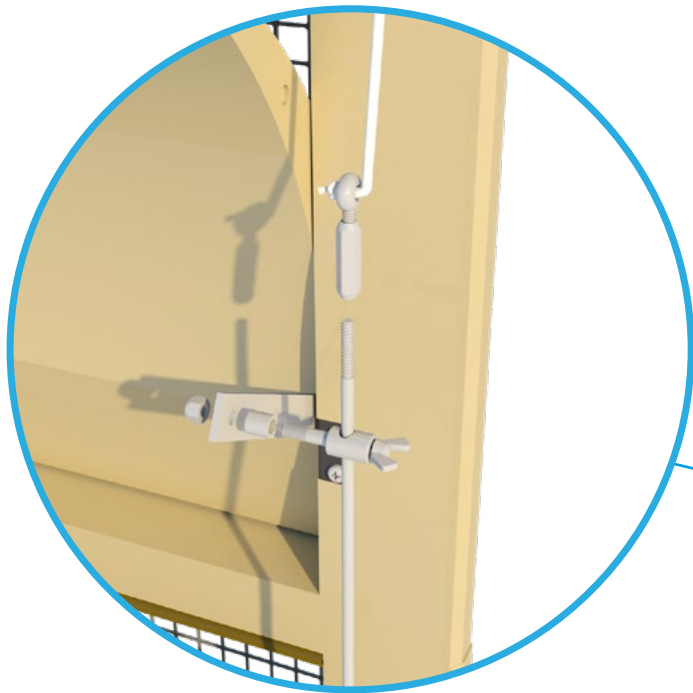

TPI-208A

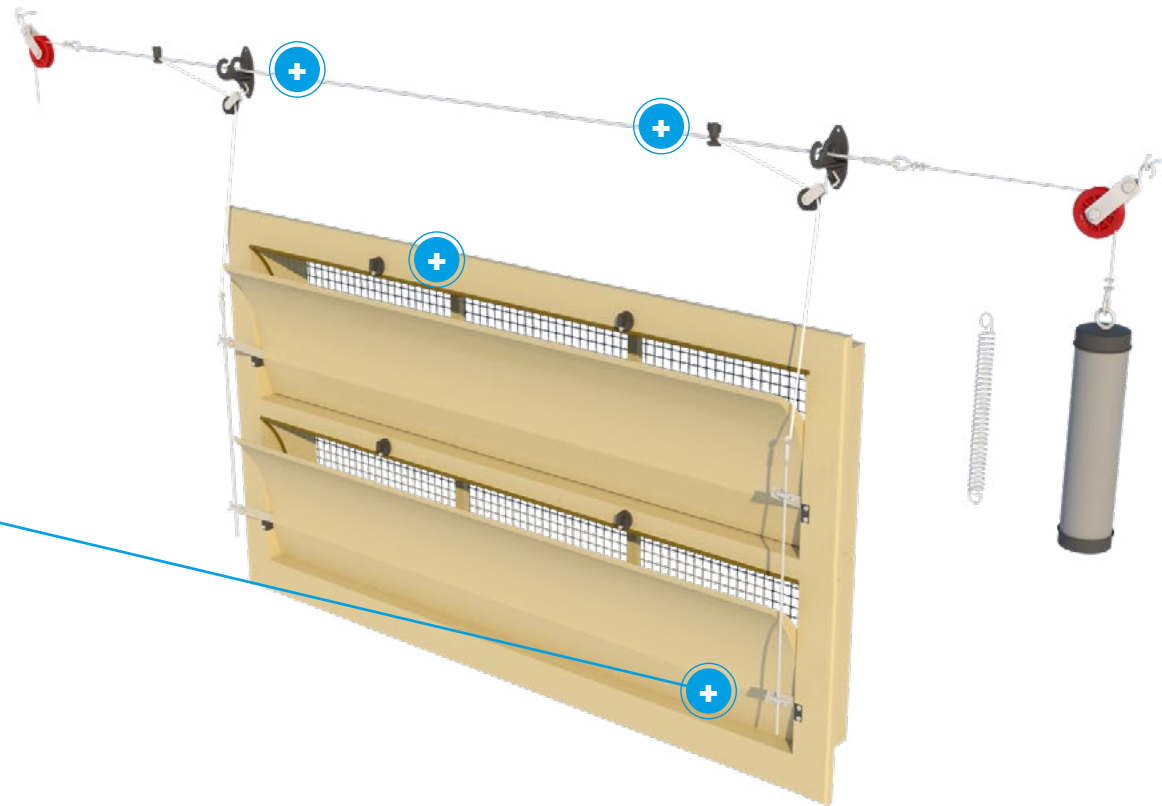

INFO

DATASHEET

ASSEMBLY

MOUNTING

WORKING

MAINTENANCE



All sizes are in cm and inches

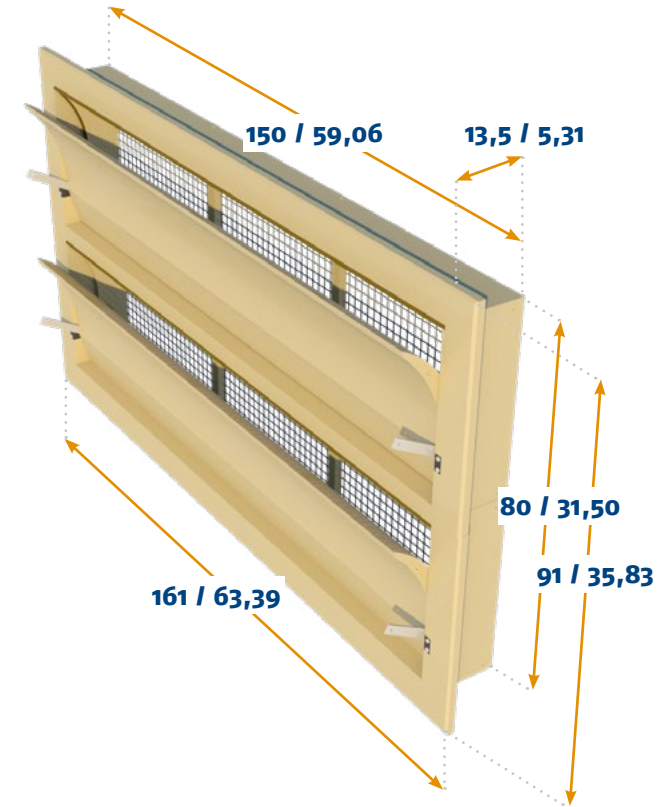
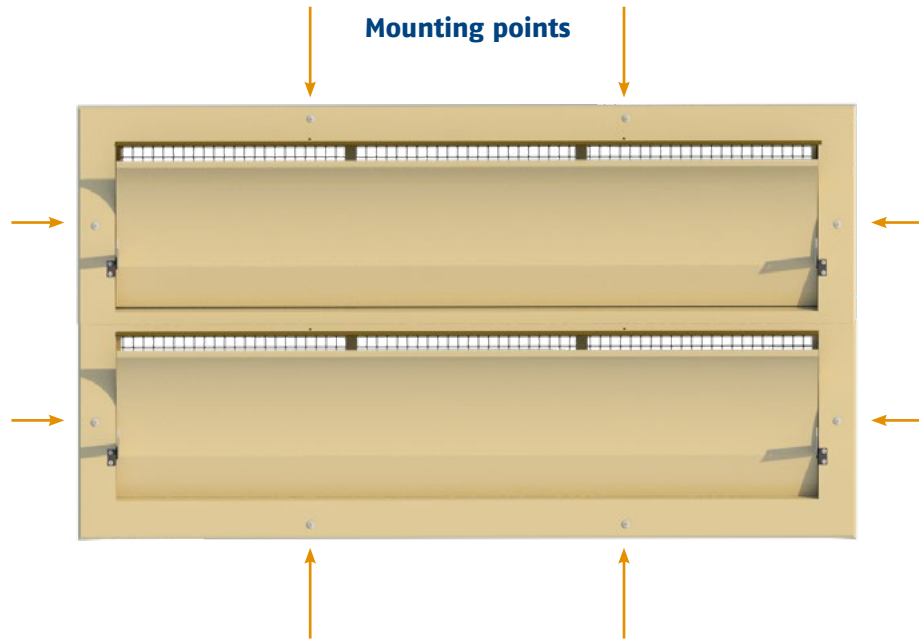

MOUNTING

Mounting type	Wall
Mounting hole size	152 cm / 59,84 inch x 82 cm / 32,28 inch

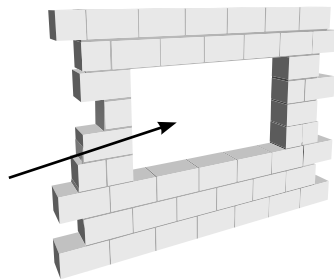

[INFO](#)

[DATASHEET](#)

[ASSEMBLY](#)

[MOUNTING](#)

[WORKING](#)

[MAINTENANCE](#)



AIR FLOW

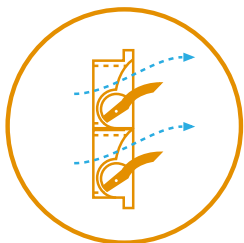

Middle hinged inlet

This middle hinged inlet is made to allow air to also flow underneath the inner flap after opening further than 35%. This helps to guide air downwards to the animals and provide a cooling effect during maximum ventilation.

Curved inner flap

This inlet is equipped with a curved inner flap. Curved flaps guide the air upwards during minimum ventilation, but also downwards after a certain point of opening. This is ideal for houses where air should be directed directly towards or over the animals during maximum ventilation.

Working with end-weights or springs

We offer two products which can be used to keep tension on the main cable. A PVC cylinder which can be filled with concrete or sand to act as end-weight, or a spring that holds tension on the cable.

Balanced set-up

When placing the motor winch or actuator we normally suggest to divide the inlets in two groups. It is preferable to place the winch or actuator in the middle to equally divide the forces on the main cable.

(see ventilation concepts page for an example)

Use of closing catches

The closing catch on the inlet can be used to permanently close inlets for example during pre-heating. The closing catches can also be used to close certain inlets while continuing to use others. In that case the used inlets can be opened a bit further. In colder climates this can help to offer better resistance to freezing effects.

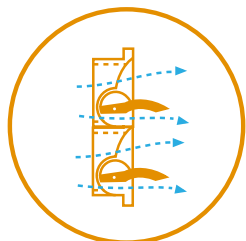
[INFO](#)
[DATASHEET](#)
[ASSEMBLY](#)
[MOUNTING](#)
[WORKING](#)
[MAINTENANCE](#)

6000-VFG-2-C

This tunnel unit is built up out of two single 6000-VFG inlets. This version is equipped with a curved inner valve that guides the air upwards during minimum ventilation. After opening further than 35% the air will also flow underneath the inner valve. This unit is controlled by two central arms per valve, which in turn, are connected with the other inner valves.



INFO

DATASHEET

ASSEMBLY

MOUNTING

WORKING

MAINTENANCE





6000-VFG-2-C DATASHEET



CAPACITY

Model	m ³ /h @ 10 Pa	m ³ /h @ 25 Pa	m ³ /h @ 40 Pa
6000-VFG-2-C	11600	17500	23200
	cfm @ 0.05 inH ₂ O	cfm @ 0.1 inH ₂ O	cfm @ 0.15 inH ₂ O
	7633	11493	13186

INFORMATION

Run	40 cm / 15.7 inch
Force	7 kg / 68.6 Newton
Number / pallet (1.65 x 0.95 x 2.40 m)	10
Weight / per inlet	21,3 kg / 47 lbs
Volume / per box	2
Arm position	3+

OPTIONAL ACCESSORIES

TPI-107 (*2)	Wire mesh synthetic
TPI-208c	Connection set
TPI-307 (*4)	Closing catch + spring
TPI-519 (*2)	Main cable support

AIR FLOW

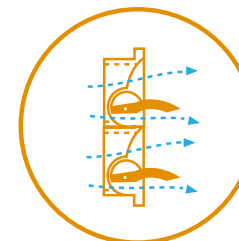
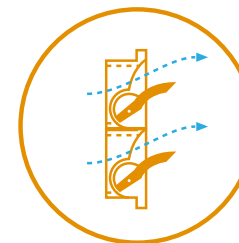

INFO

DATASHEET

ASSEMBLY

MOUNTING

WORKING

MAINTENANCE



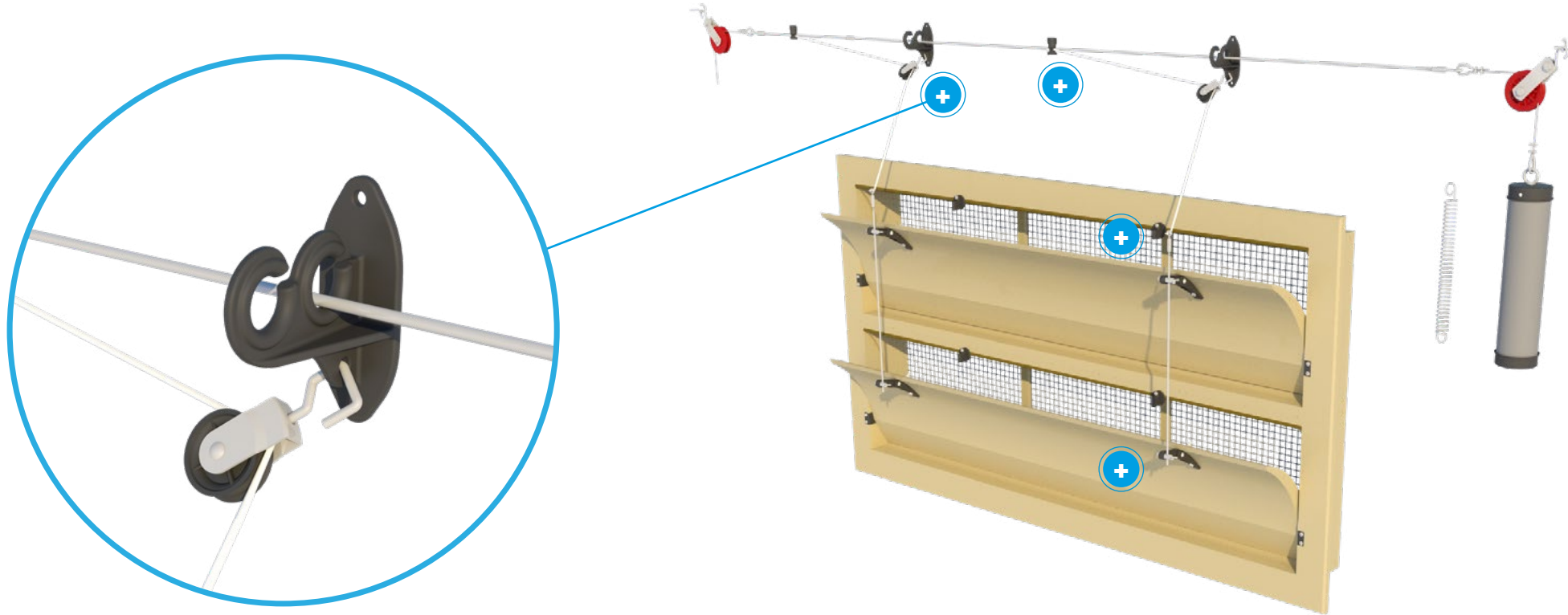

TPI-519

INFO

DATASHEET

ASSEMBLY

MOUNTING

WORKING

MAINTENANCE





TPI-208A

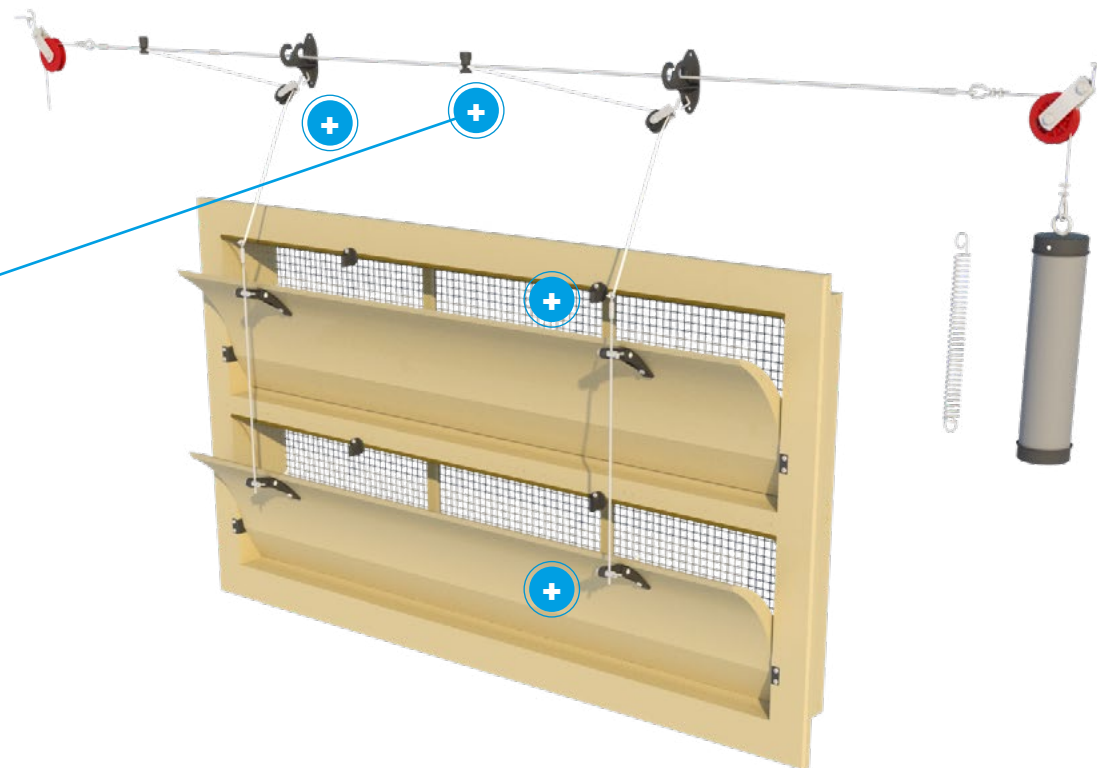

[INFO](#)

[DATASHEET](#)

[ASSEMBLY](#)

[MOUNTING](#)

[WORKING](#)

[MAINTENANCE](#)



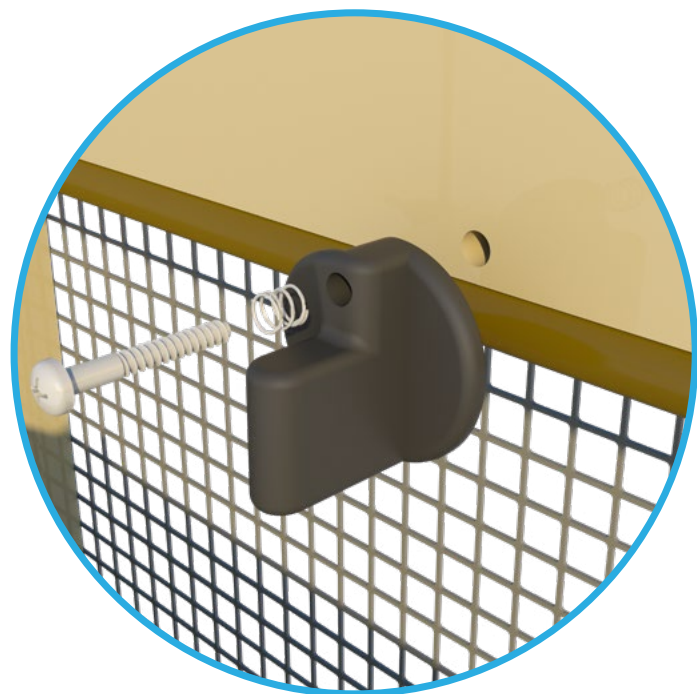

TPI-307

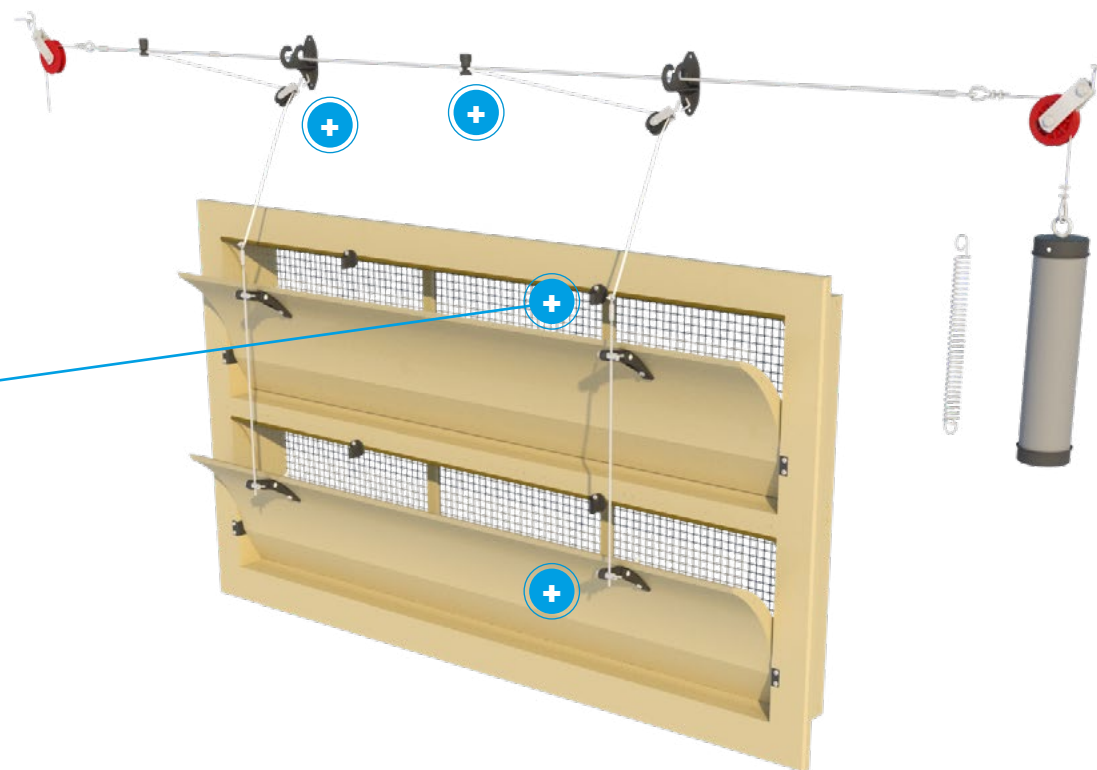

INFO

DATASHEET

ASSEMBLY

MOUNTING

WORKING

MAINTENANCE





6000-VFG-2-C ASSEMBLY



TPI-208A

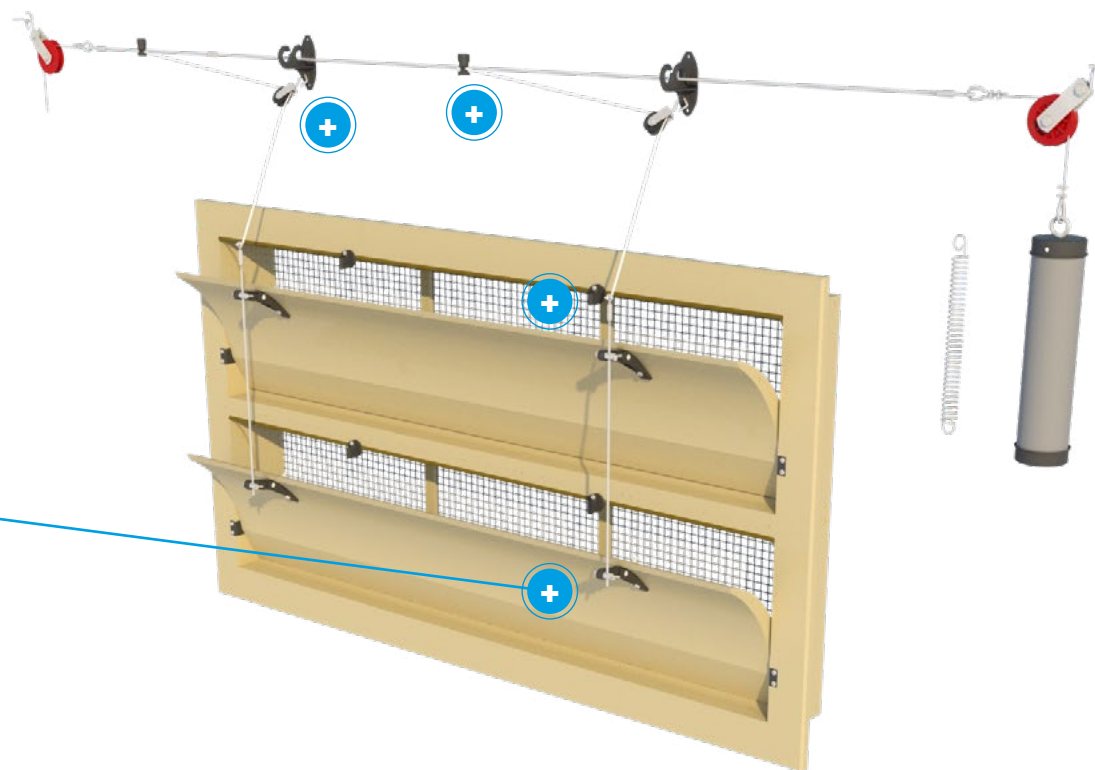

[INFO](#)

[DATASHEET](#)

[ASSEMBLY](#)

[MOUNTING](#)

[WORKING](#)

[MAINTENANCE](#)



All sizes are in cm and inches

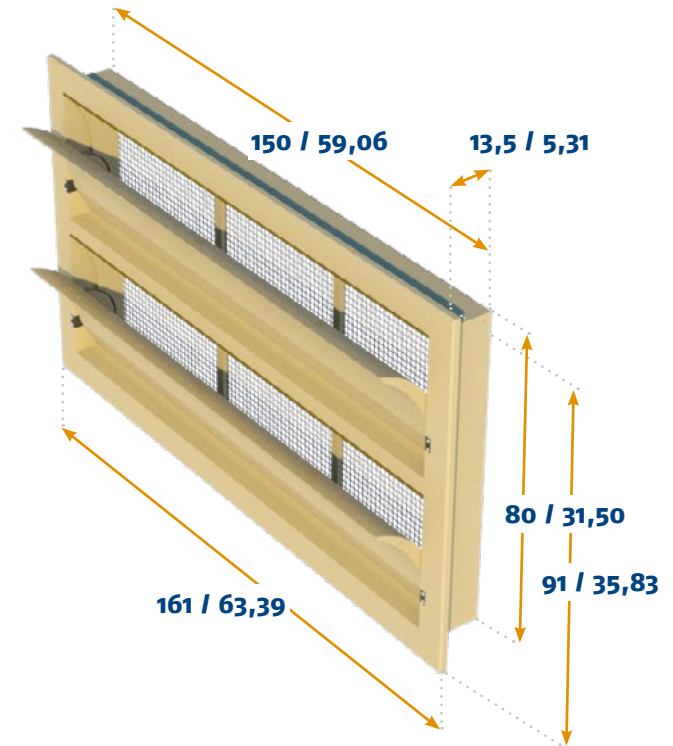
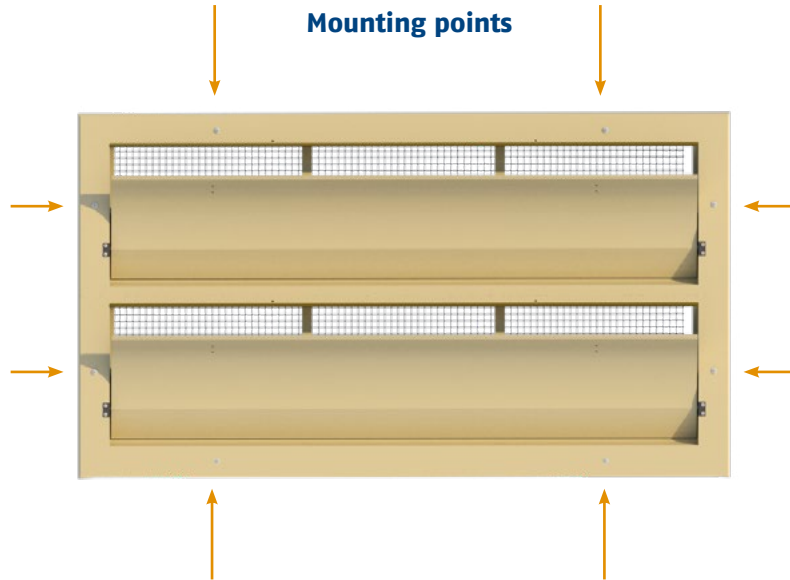

MOUNTING

Mounting type	Wall
Mounting hole size	152 cm / 59,84 inch x 82 cm / 32,28 inch

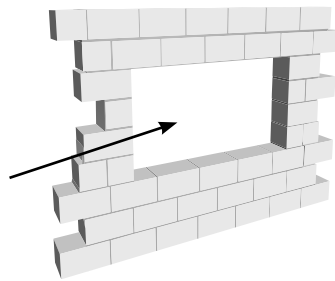

INFO

DATASHEET

ASSEMBLY

MOUNTING

WORKING

MAINTENANCE



AIR FLOW

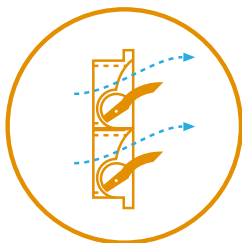

Middle hinged inlet

This middle hinged inlet is made to allow air to also flow underneath the inner flap after opening further than 35%. This helps to guide air downwards to the animals and provide a cooling effect during maximum ventilation.

Curved inner flap

This inlet is equipped with a curved inner flap. Curved flaps guide the air upwards during minimum ventilation, but also downwards after a certain point of opening. This is ideal for houses where air should be directed directly towards or over the animals during maximum ventilation.

Working with end-weights or springs

We offer two products which can be used to keep tension on the main cable. A PVC cylinder which can be filled with concrete or sand to act as end-weight, or a spring that holds tension on the cable.

Balanced set-up

When placing the motor winch or actuator we normally suggest to divide the inlets in two groups. It is preferable to place the winch or actuator in the middle to equally divide the forces on the main cable.

(see ventilation concepts page for an example)

Use of closing catches

The closing catch on the inlet can be used to permanently close inlets for example during pre-heating. The closing catches can also be used to close certain inlets while continuing to use others. In that case the used inlets can be opened a bit further. In colder climates this can help to offer better resistance to freezing effects.



INFO

DATASHEET

ASSEMBLY

MOUNTING

WORKING

MAINTENANCE



6000-VFG-3

This tunnel unit is built up out of three single 6000-VFG inlets. This version is equipped with a curved inner valve that guides the air upwards during minimum ventilation. After opening further than 35% the air will also flow underneath the inner valve. This unit is controlled by side arms that connect the inner valves.

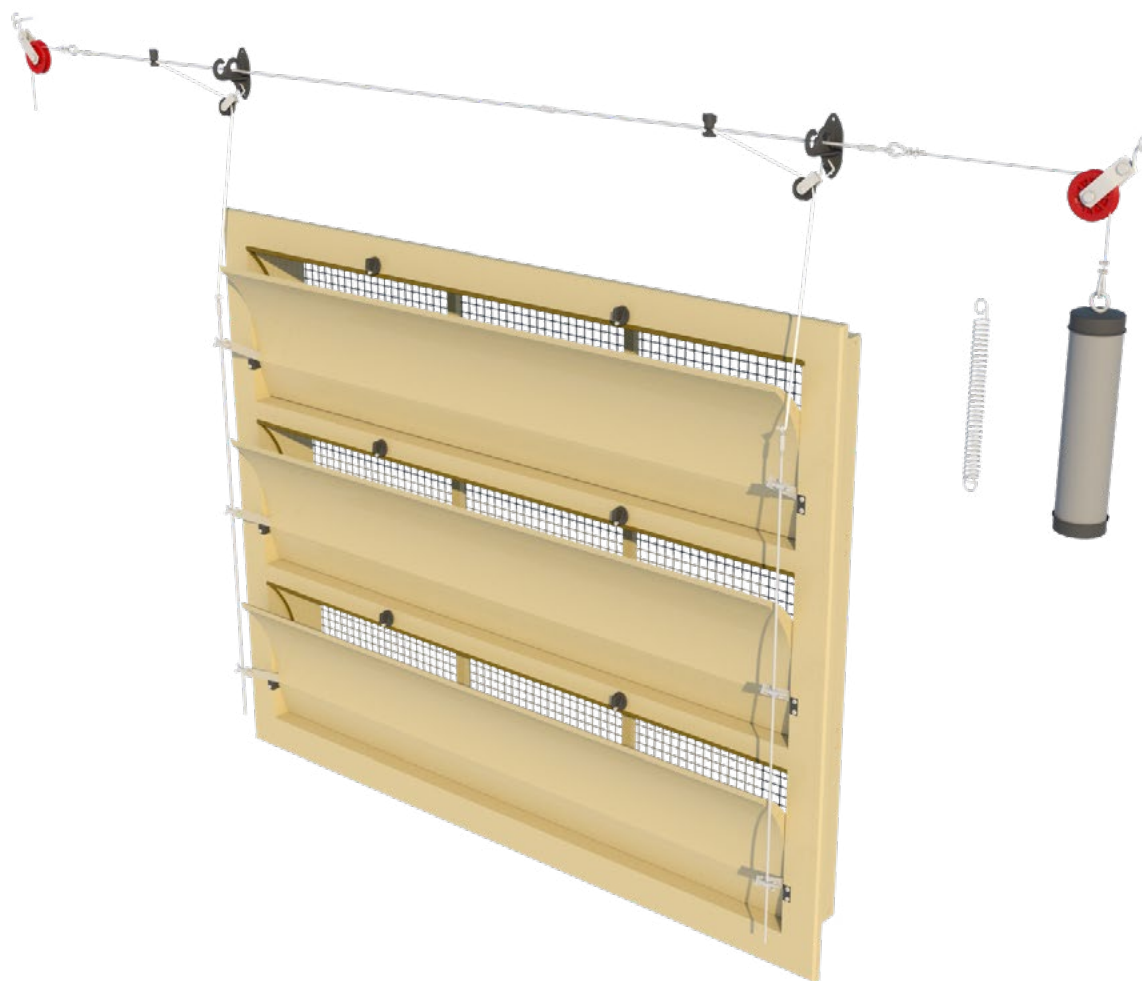

INFO

DATASHEET

ASSEMBLY

MOUNTING

WORKING

MAINTENANCE





6000-VFG-3 DATASHEET



CAPACITY

Model	m ³ /h @ 10 Pa	m ³ /h @ 25 Pa	m ³ /h @ 40 Pa
6000-VFG-3	17400	26250	34800
	cfm @ 0.05 inH ₂ O	cfm @ 0.1 inH ₂ O	cfm @ 0.15 inH ₂ O
	11450	17239	19779

INFORMATION

Run	18 cm / 7.1 inch
Force	27 kg / 265 Newton
Number / pallet (1.65 x 0.95 x 2.40 m)	5
Weight / per inlet	31,9 kg / 70.3 lbs
Volume / per box	1

OPTIONAL ACCESSORIES

TPI-107 (*3)	Wire mesh synthetic
TPI-209a	Connection set
TPI-307 (*6)	Closing catch + spring
TPI-519 (*2)	Main cable support

AIR FLOW

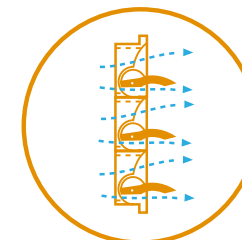
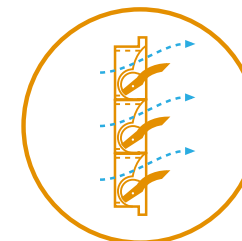

INFO

DATASHEET

ASSEMBLY

MOUNTING

WORKING

MAINTENANCE



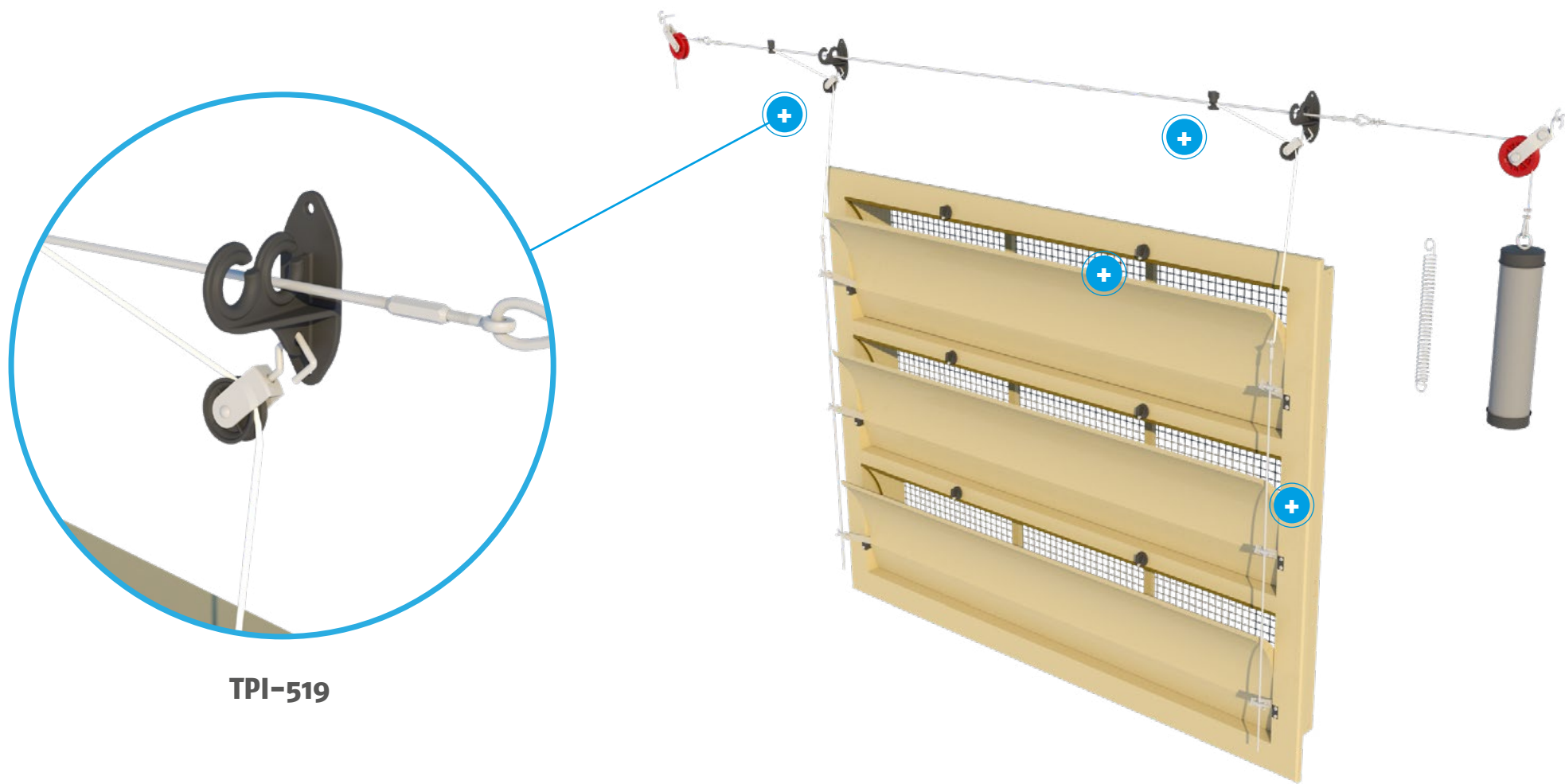

TPI-519



TPI-209A

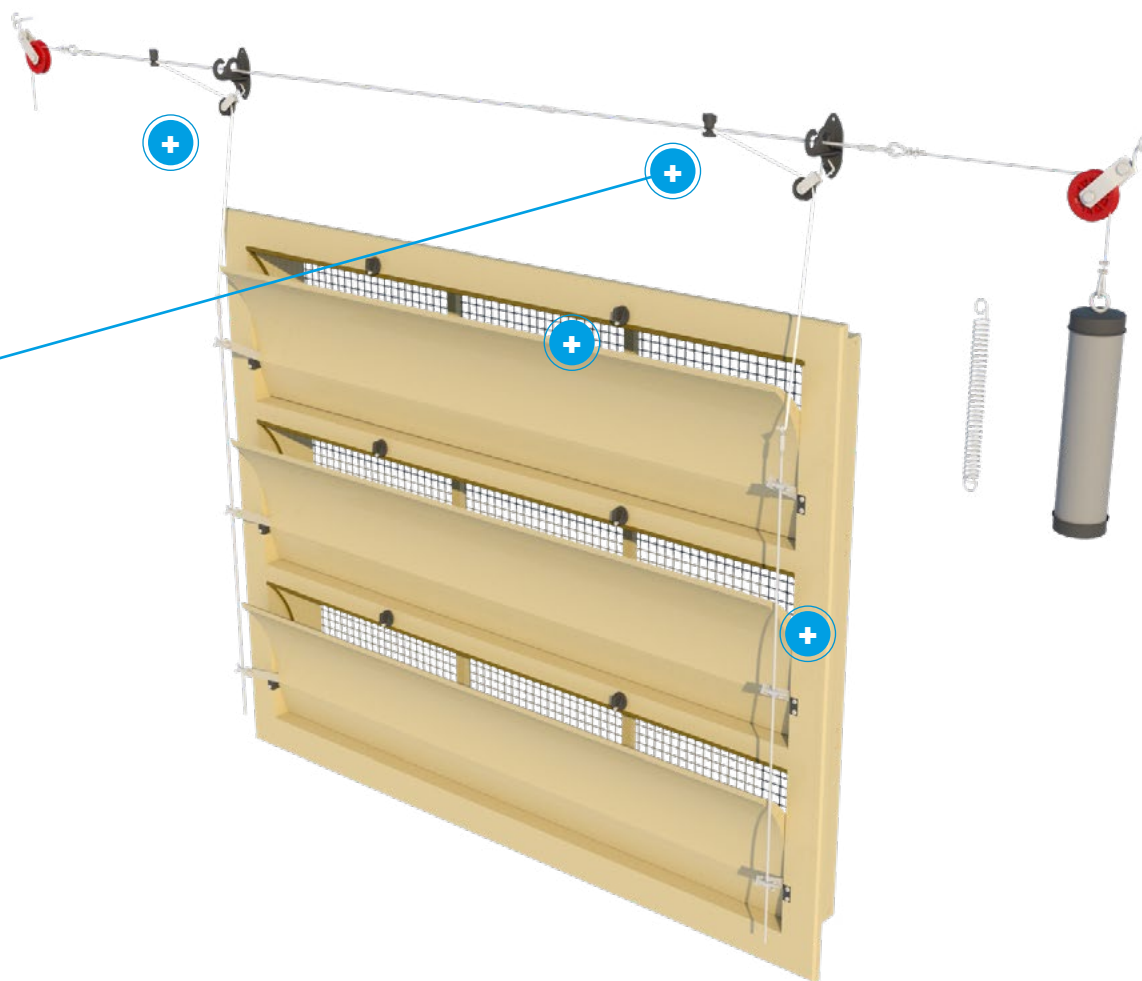

INFO

DATASHEET

ASSEMBLY

MOUNTING

WORKING

MAINTENANCE



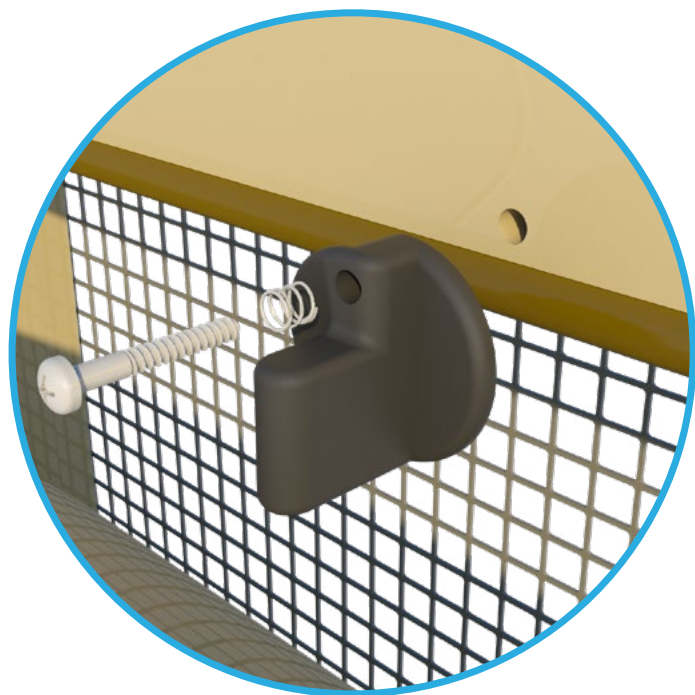

TPI-307

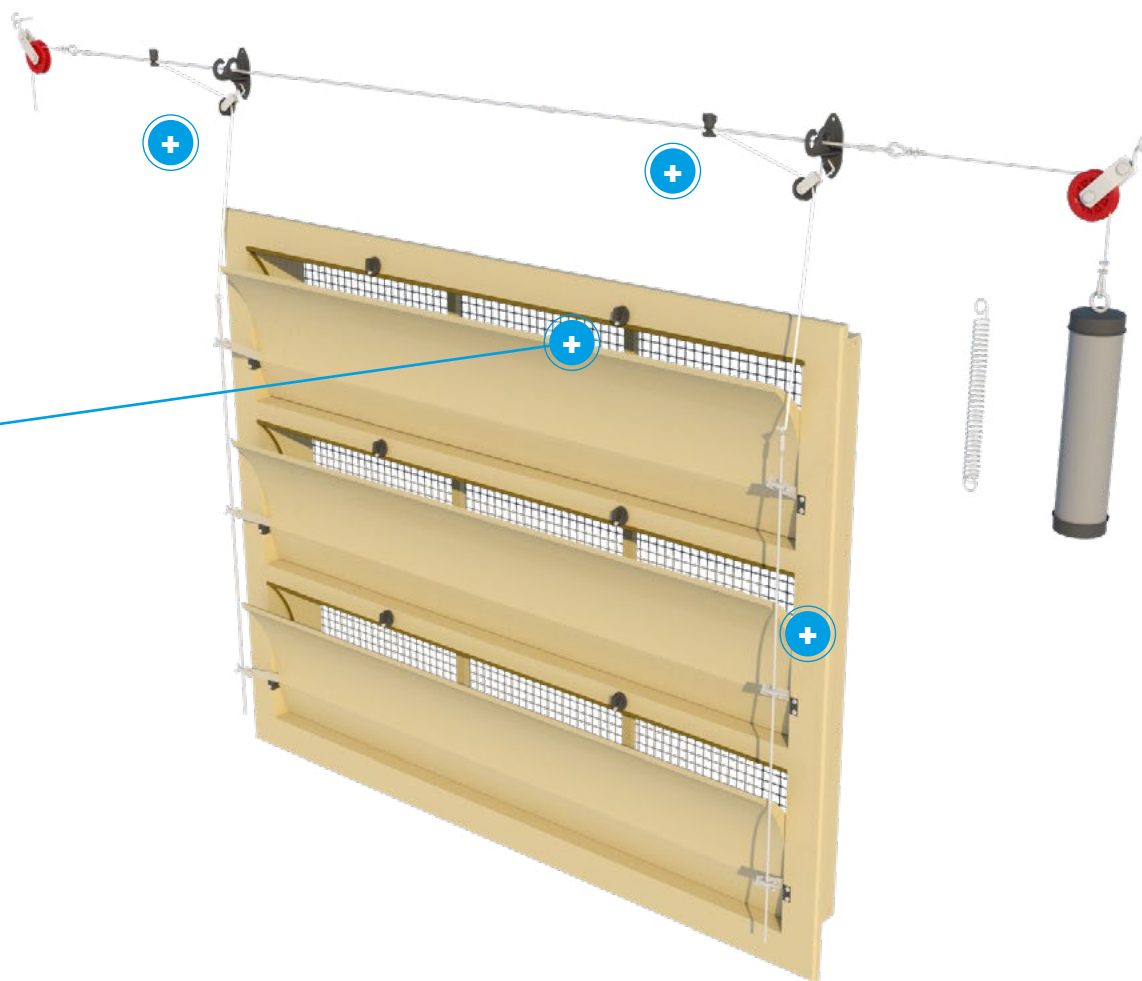

INFO

DATASHEET

ASSEMBLY

MOUNTING

WORKING

MAINTENANCE



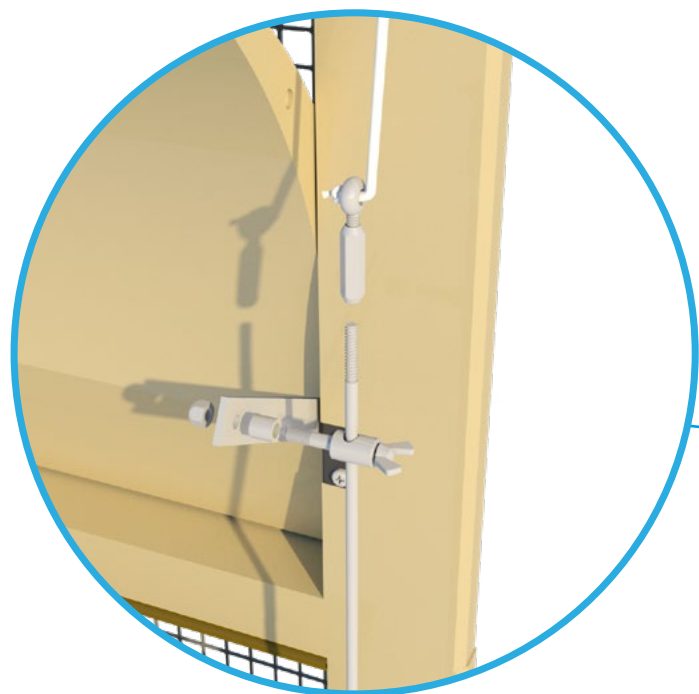

TPI-209A

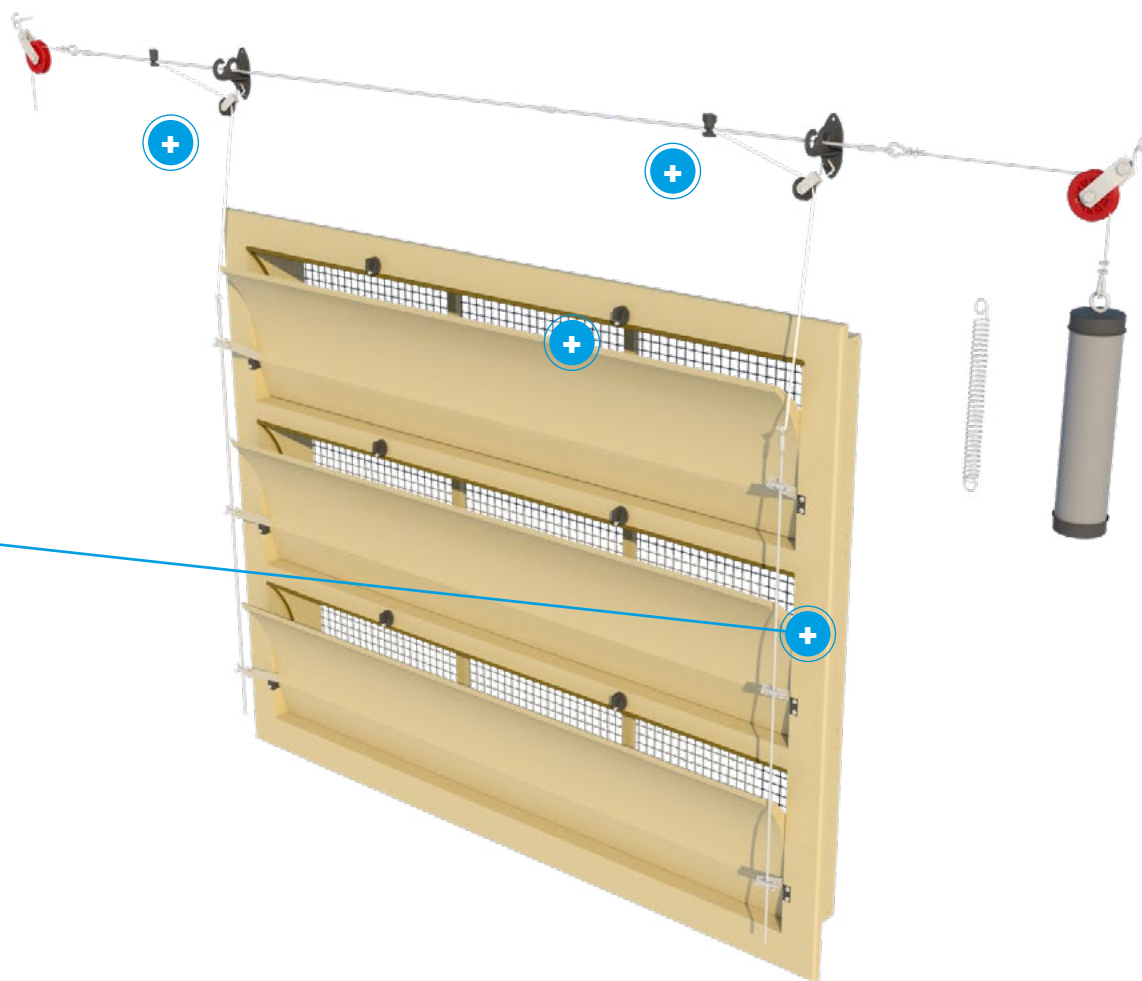

6000-VFG-3 MOUNTING

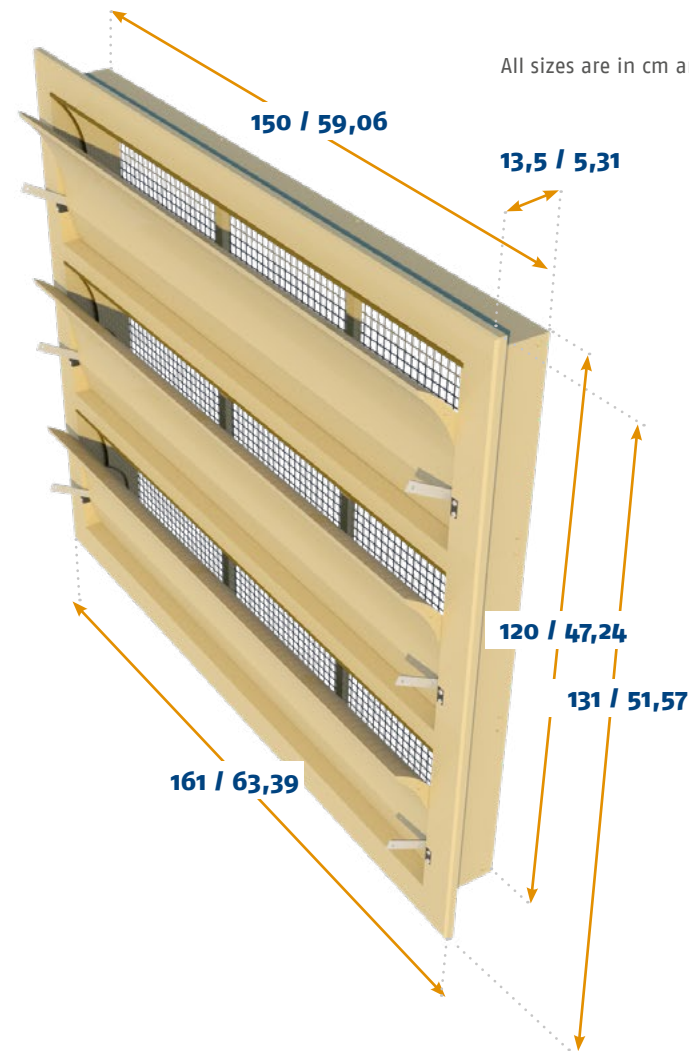
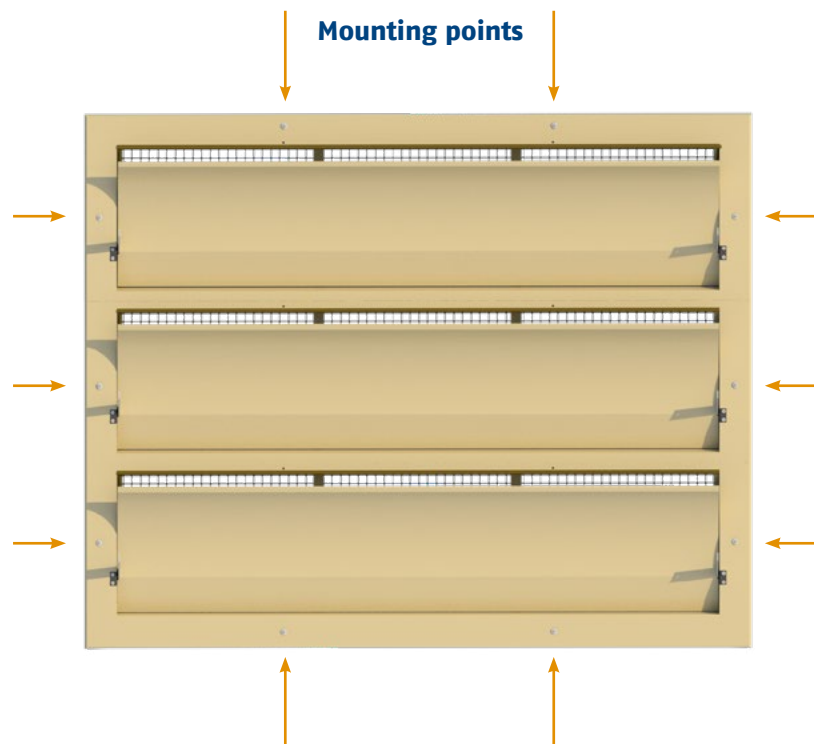

MOUNTING	
Mounting type	Wall
Mounting hole size	152 cm / 59,84 inch x 122 cm / 48,03 inch

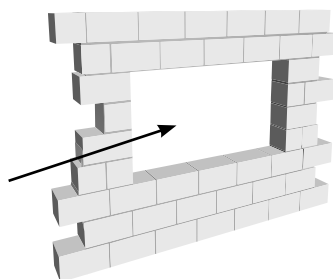

AIR FLOW

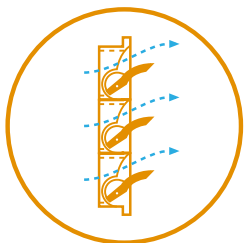

Middle hinged inlet

This middle hinged inlet is made to allow air to also flow underneath the inner flap after opening further than 35%. This helps to guide air downwards to the animals and provide a cooling effect during maximum ventilation.

Curved inner flap

This inlet is equipped with a curved inner flap. Curved flaps guide the air upwards during minimum ventilation, but also downwards after a certain point of opening. This is ideal for houses where air should be directed directly towards or over the animals during maximum ventilation.

Working with end-weights or springs

We offer two products which can be used to keep tension on the main cable. A PVC cylinder which can be filled with concrete or sand to act as end-weight, or a spring that holds tension on the cable.

Balanced set-up

When placing the motor winch or actuator we normally suggest to divide the inlets in two groups. It is preferable to place the winch or actuator in the middle to equally divide the forces on the main cable.

(see ventilation concepts page for an example)

Use of closing catches

The closing catch on the inlet can be used to permanently close inlets for example during pre-heating. The closing catches can also be used to close certain inlets while continuing to use others. In that case the used inlets can be opened a bit further. In colder climates this can help to offer better resistance to freezing effects.

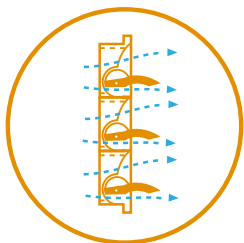
[INFO](#)
[DATASHEET](#)
[ASSEMBLY](#)
[MOUNTING](#)
[WORKING](#)
[MAINTENANCE](#)

6000-VFG-3-C

This tunnel unit is built up out of three single 6000-VFG inlets. This version is equipped with a curved inner valve that guides the air upwards during minimum ventilation. After opening further than 35% the air will also flow underneath the inner valve. This unit is controlled by two central arms per valve, which in turn, are connected with the other inner valves.



INFO

DATASHEET

ASSEMBLY

MOUNTING

WORKING

MAINTENANCE





6000-VFG-3-C DATASHEET



CAPACITY

Model	m ³ /h @ 10 Pa	m ³ /h @ 25 Pa	m ³ /h @ 40 Pa
6000-VFG-3-C	17400	26250	34800
	cfm @ 0.05 inH ₂ O	cfm @ 0.1 inH ₂ O	cfm @ 0.15 inH ₂ O
	11450	17239	19779

INFORMATION

Run	40 cm / 15.7 inch
Force	10,5 kg / 103 Newton
Number / pallet (1.65 x 0.95 x 2.40 m)	5
Weight / per inlet	31,9 kg / 70.3 lbs
Volume / per box	1
Arm position	3+

OPTIONAL ACCESSORIES

TPI-107 (*3)	Wire mesh synthetic
TPI-209c	Connection set
TPI-307 (*6)	Closing catch + spring
TPI-519 (*2)	Main cable support

AIR FLOW

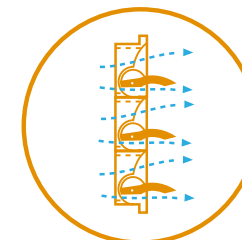
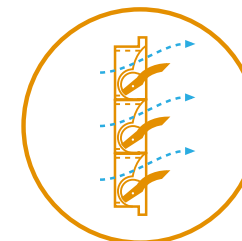

INFO

DATASHEET

ASSEMBLY

MOUNTING

WORKING

MAINTENANCE



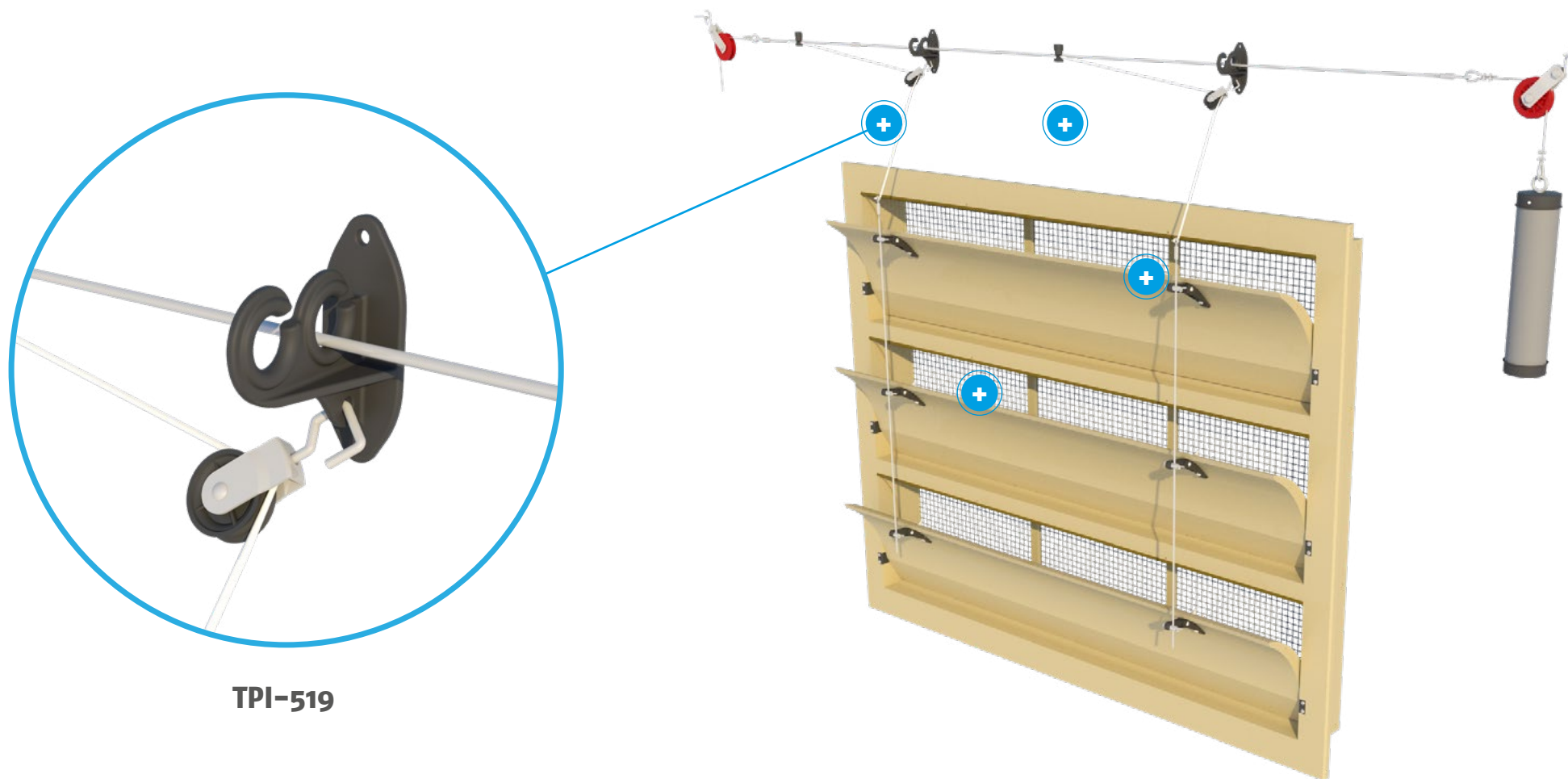

TPI-519

INFO

DATASHEET

ASSEMBLY

MOUNTING

WORKING

MAINTENANCE





TPI-209A

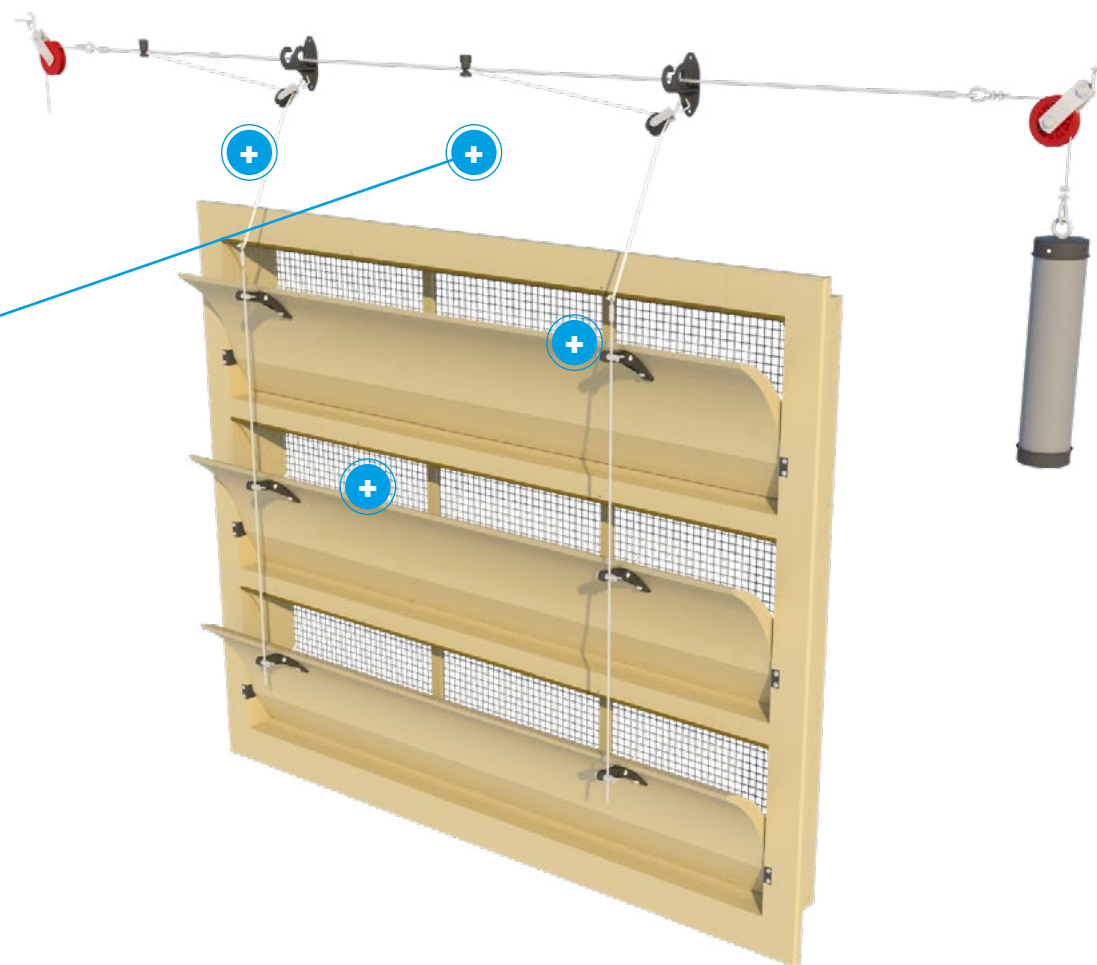

INFO

DATASHEET

ASSEMBLY

MOUNTING

WORKING

MAINTENANCE



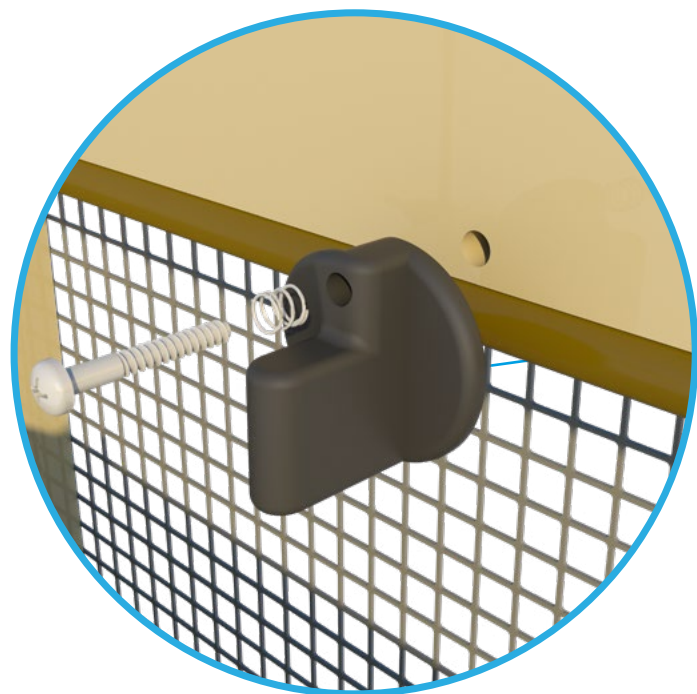

TPI-307

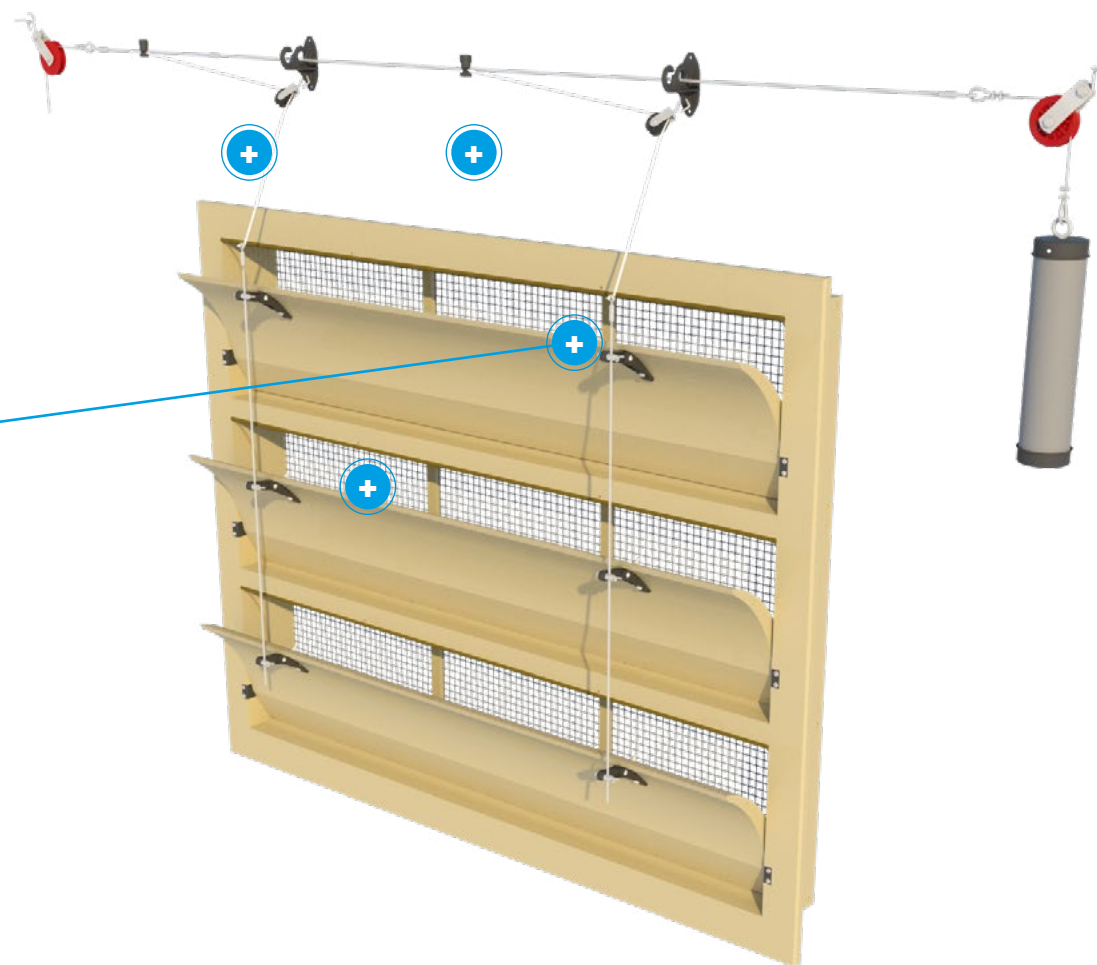

INFO

DATASHEET

ASSEMBLY

MOUNTING

WORKING

MAINTENANCE





TPI-209A

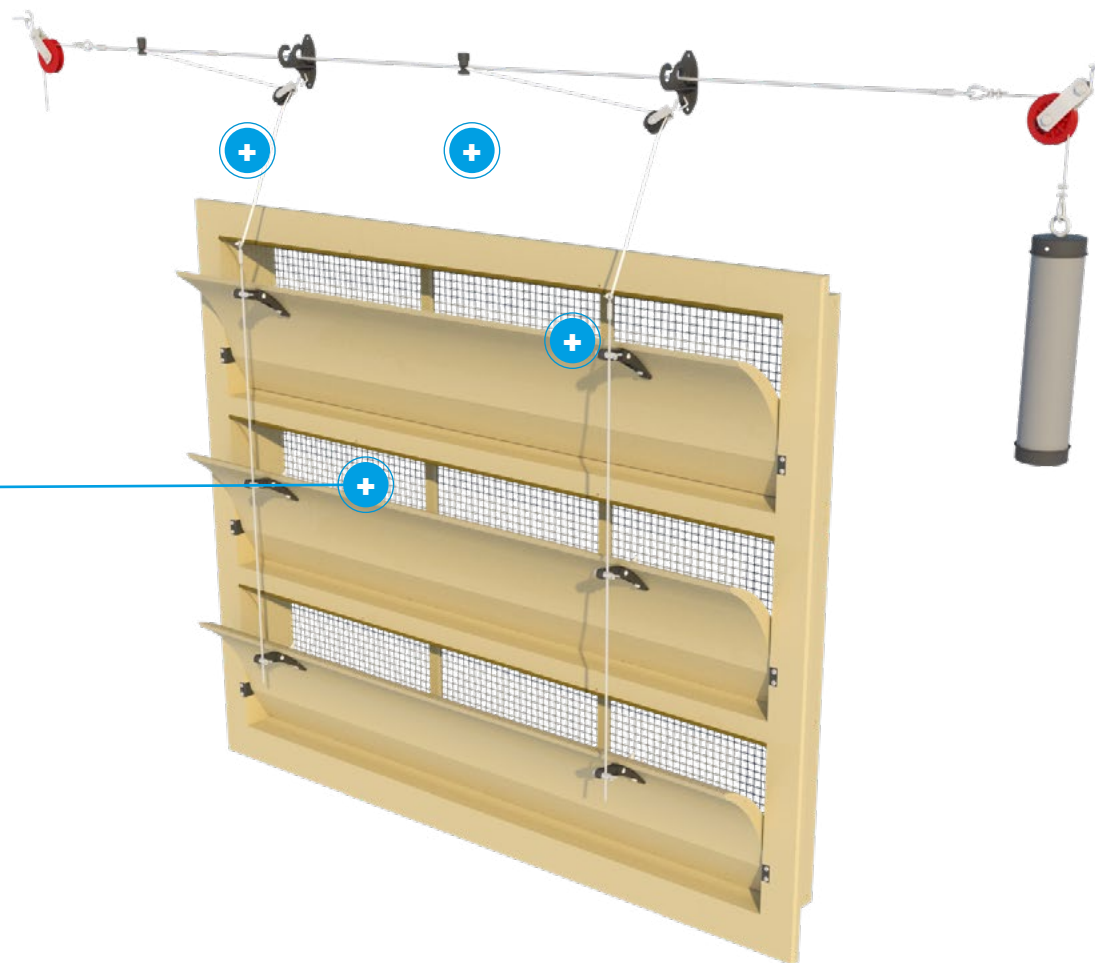

INFO

DATASHEET

ASSEMBLY

MOUNTING

WORKING

MAINTENANCE



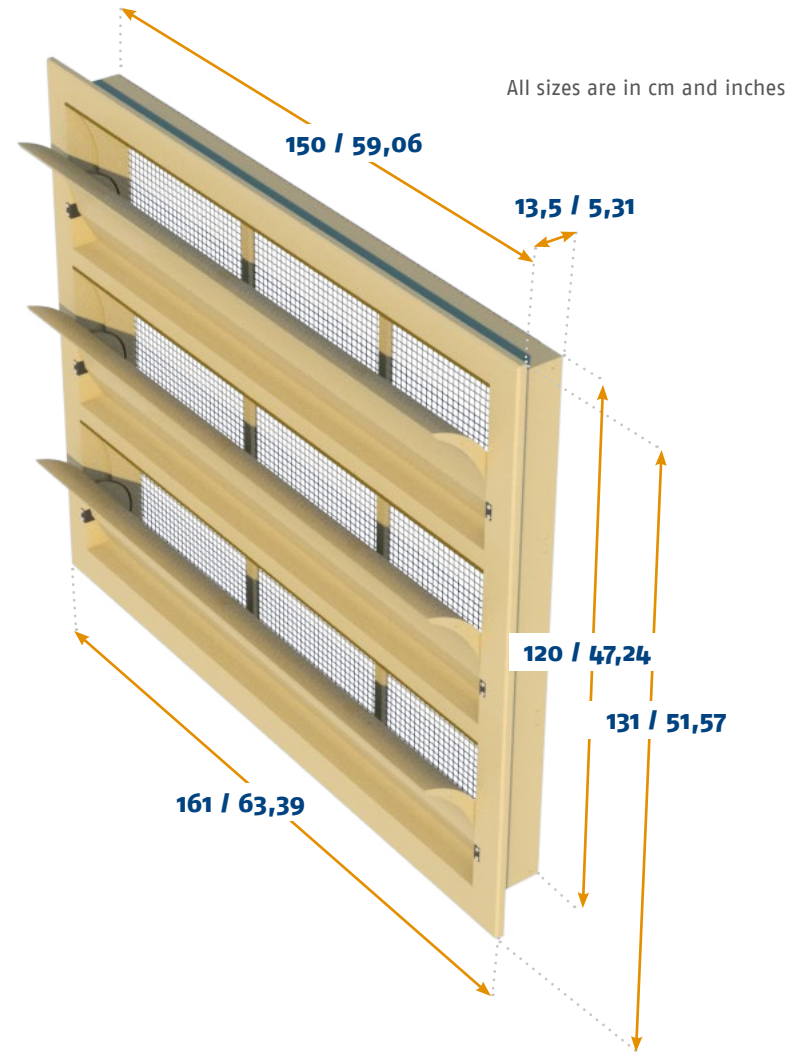
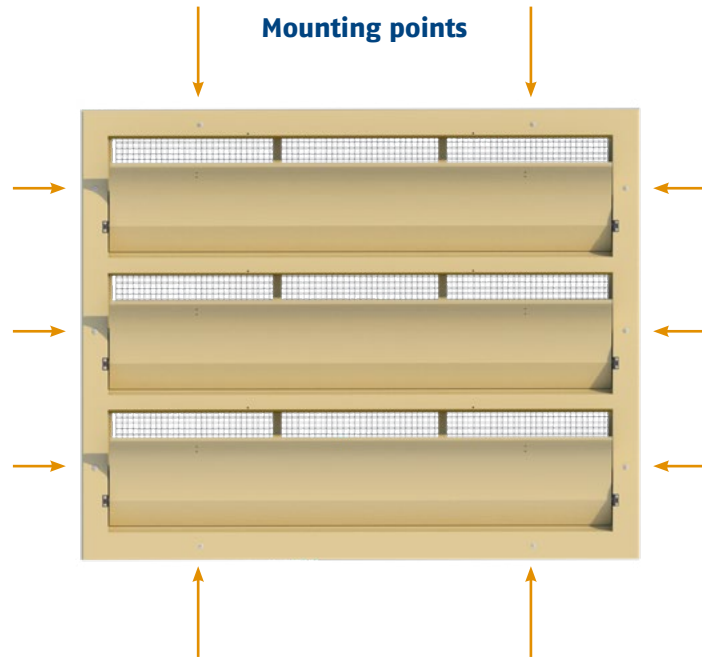

MOUNTING	
Mounting type	Wall
Mounting hole size	152 cm / 59,84 inch x 122 cm / 48,03 inch

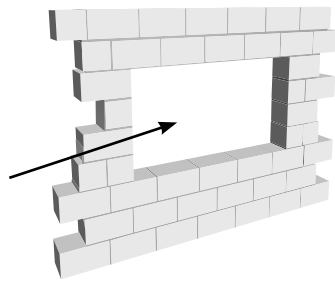

AIR FLOW

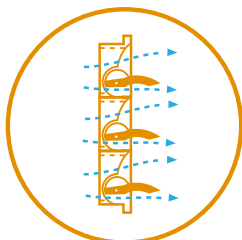
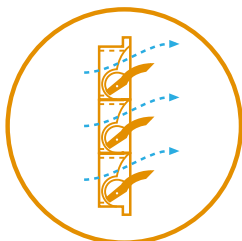

Middle hinged inlet

This middle hinged inlet is made to allow air to also flow underneath the inner flap after opening further than 35%. This helps to guide air downwards to the animals and provide a cooling effect during maximum ventilation.

Curved inner flap

This inlet is equipped with a curved inner flap. Curved flaps guide the air upwards during minimum ventilation, but also downwards after a certain point of opening. This is ideal for houses where air should be directed directly towards or over the animals during maximum ventilation.

Working with end-weights or springs

We offer two products which can be used to keep tension on the main cable. A PVC cylinder which can be filled with concrete or sand to act as end-weight, or a spring that holds tension on the cable.

Balanced set-up

When placing the motor winch or actuator we normally suggest to divide the inlets in two groups. It is preferable to place the winch or actuator in the middle to equally divide the forces on the main cable.

(see ventilation concepts page for an example)

Use of closing catches

The closing catch on the inlet can be used to permanently close inlets for example during pre-heating. The closing catches can also be used to close certain inlets while continuing to use others. In that case the used inlets can be opened a bit further. In colder climates this can help to offer better resistance to freezing effects.

[INFO](#)
[DATASHEET](#)
[ASSEMBLY](#)
[MOUNTING](#)
[WORKING](#)
[MAINTENANCE](#)

6000-VFG-4

This tunnel unit is built up out of four single 6000-VFG inlets. This version is equipped with a curved inner valve that guides the air upwards during minimum ventilation. After opening further than 35% the air will also flow underneath the inner valve. This unit is controlled by two central arms per valve, which in turn, are connected with the other inner valves.



INFO

DATASHEET

ASSEMBLY

MOUNTING

WORKING

MAINTENANCE





6000-VFG-4 DATASHEET



CAPACITY

Model	m ³ /h @ 10 Pa	m ³ /h @ 25 Pa	m ³ /h @ 40 Pa
6000-VFG-4	23200	35000	46400
	cfm @ 0.05 inH ₂ O	cfm @ 0.1 inH ₂ O	cfm @ 0.15 inH ₂ O
	15267	22986	26372

INFORMATION

Run	18 cm / 7.1 inch
Force	36 kg / 352 Newton
Number / pallet (1.65 x 0.95 x 2.40 m)	5
Weight / per inlet	42,5 kg / 93.7 lbs
Volume / per box	1

OPTIONAL ACCESSORIES

TPI-107 (*4)	Wire mesh synthetic
TPI-210a	Connection set
TPI-307 (*8)	Closing catch + spring
TPI-519 (*2)	Main cable support

AIR FLOW

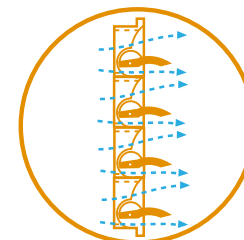
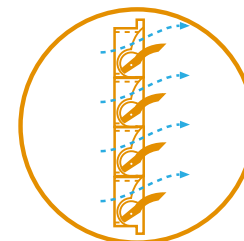

INFO

DATASHEET

ASSEMBLY

MOUNTING

WORKING

MAINTENANCE



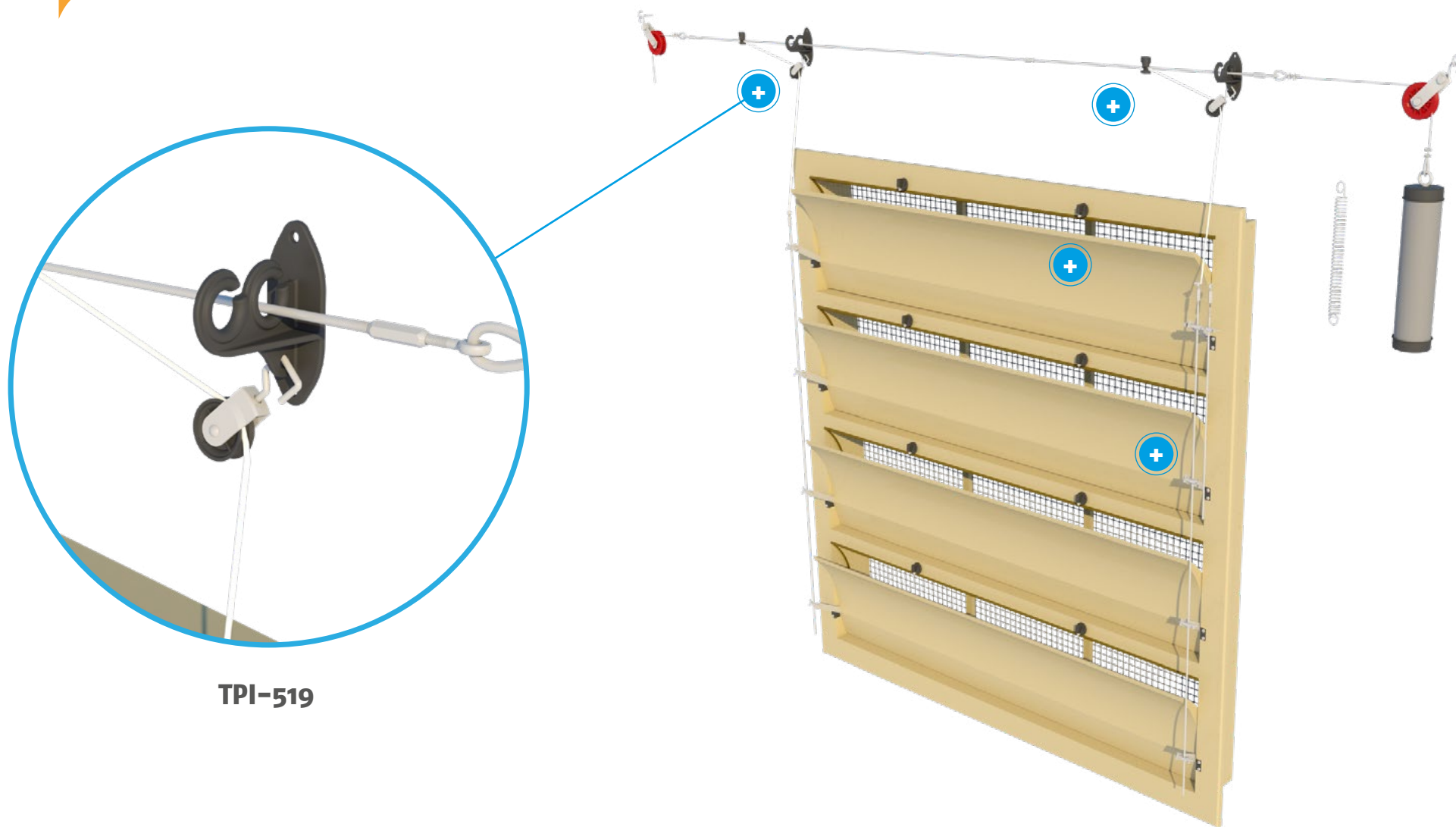

TPI-519

INFO

DATASHEET

ASSEMBLY

MOUNTING

WORKING

MAINTENANCE





TPI-210A

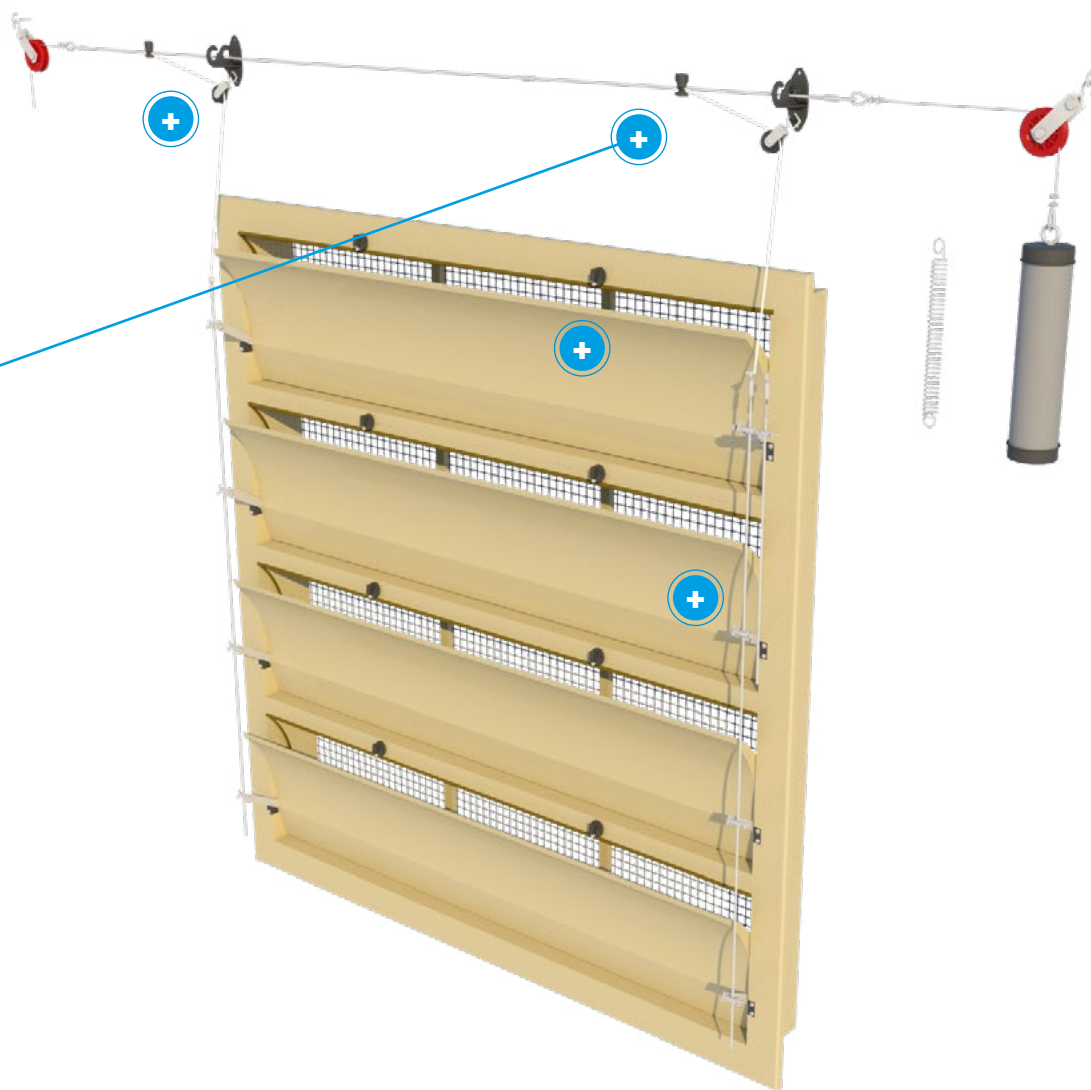

INFO

DATASHEET

ASSEMBLY

MOUNTING

WORKING

MAINTENANCE



6000-VFG-4 ASSEMBLY

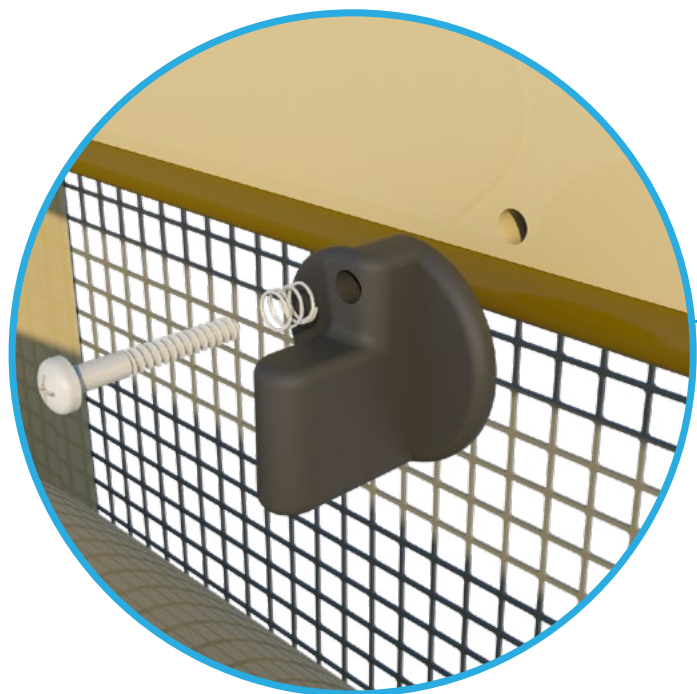

TPI-307

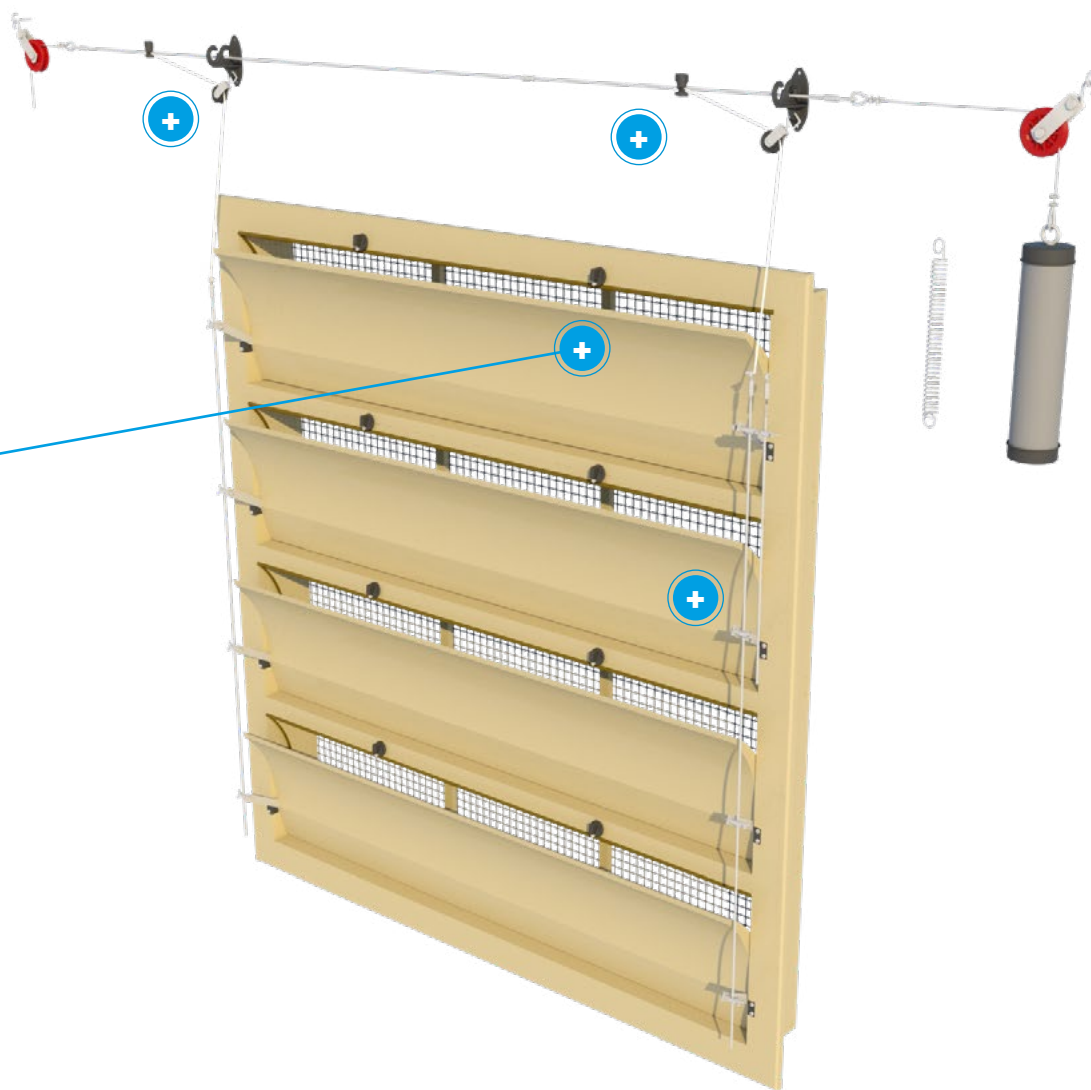

INFO

DATASHEET

ASSEMBLY

MOUNTING

WORKING

MAINTENANCE



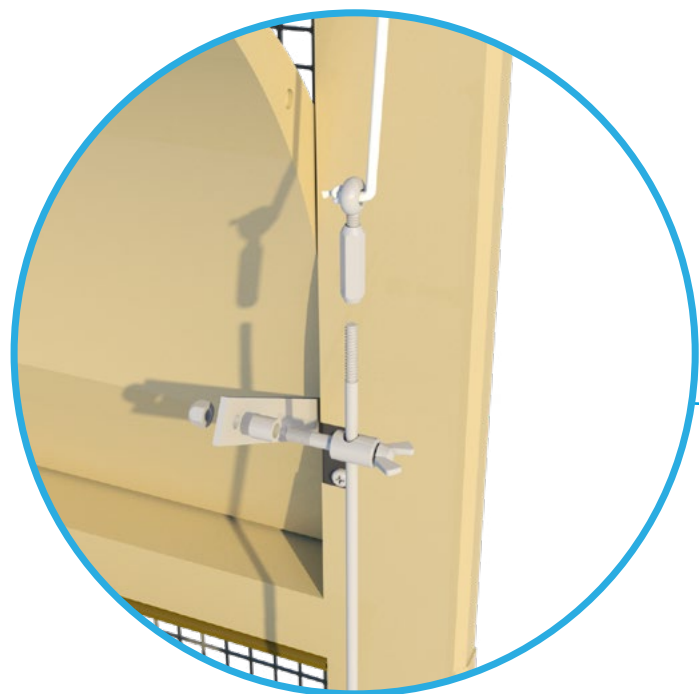

TPI-210A

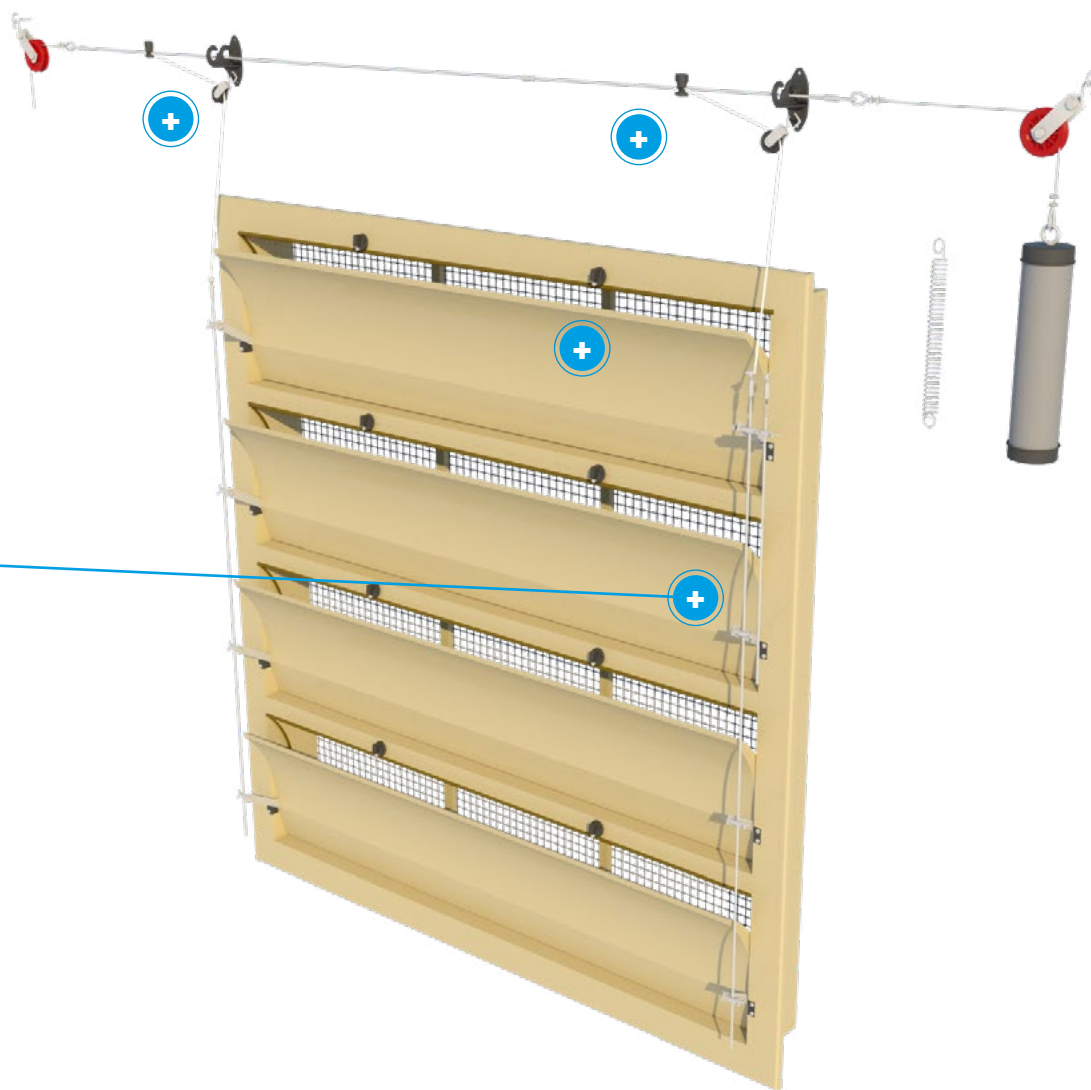

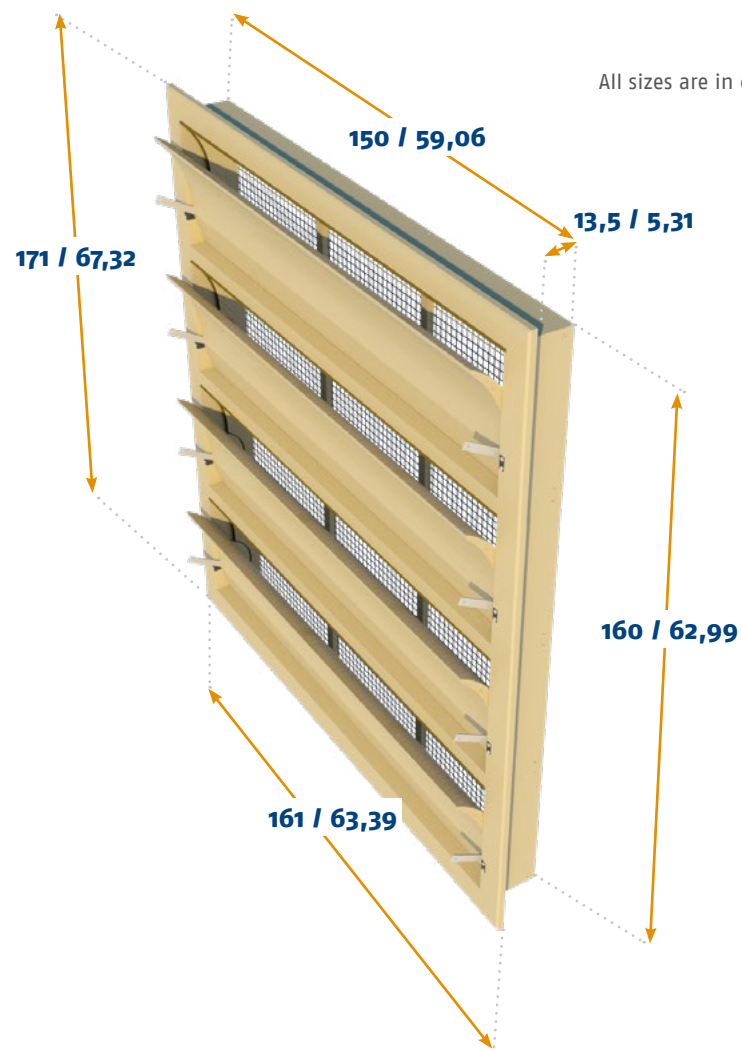
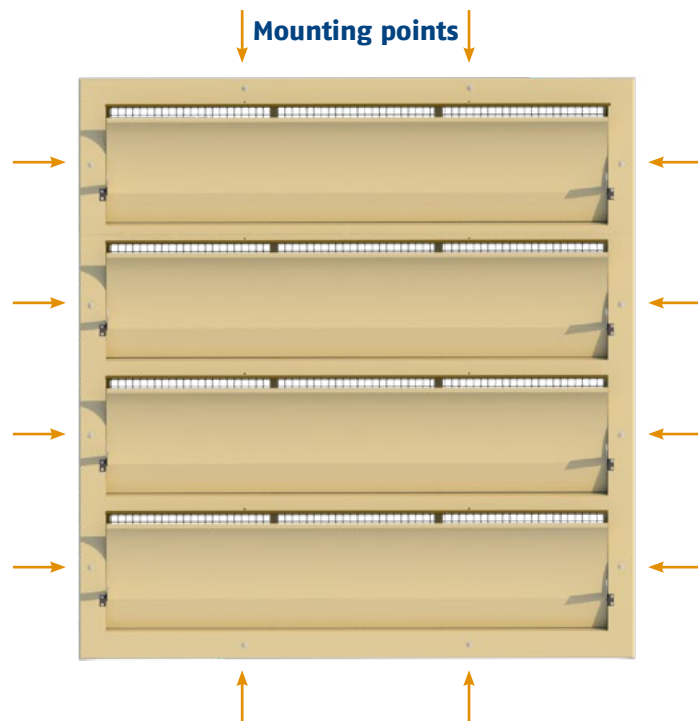

All sizes are in cm and inches

MOUNTING

Mounting type	Wall
Mounting hole size	152 cm / 59,84 inch x 162 cm / 63,78 inch

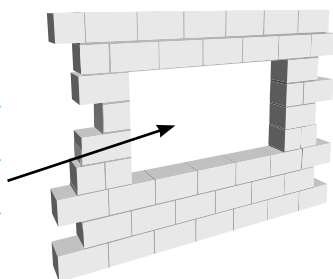

[INFO](#)

[DATASHEET](#)

[ASSEMBLY](#)

[MOUNTING](#)

[WORKING](#)

[MAINTENANCE](#)



AIR FLOW

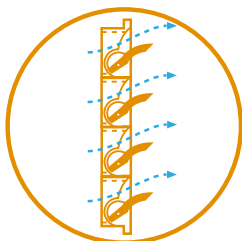

Middle hinged inlet

This middle hinged inlet is made to allow air to also flow underneath the inner flap after opening further than 35%. This helps to guide air downwards to the animals and provide a cooling effect during maximum ventilation.

Curved inner flap

This inlet is equipped with a curved inner flap. Curved flaps guide the air upwards during minimum ventilation, but also downwards after a certain point of opening. This is ideal for houses where air should be directed directly towards or over the animals during maximum ventilation.

Working with end-weights or springs

We offer two products which can be used to keep tension on the main cable. A PVC cylinder which can be filled with concrete or sand to act as end-weight, or a spring that holds tension on the cable.

Balanced set-up

When placing the motor winch or actuator we normally suggest to divide the inlets in two groups. It is preferable to place the winch or actuator in the middle to equally divide the forces on the main cable.

(see ventilation concepts page for an example)

Use of closing catches

The closing catch on the inlet can be used to permanently close inlets for example during pre-heating. The closing catches can also be used to close certain inlets while continuing to use others. In that case the used inlets can be opened a bit further. In colder climates this can help to offer better resistance to freezing effects.

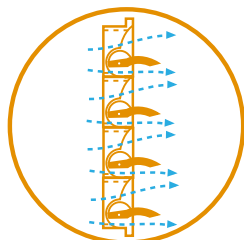
[INFO](#)
[DATASHEET](#)
[ASSEMBLY](#)
[MOUNTING](#)
[WORKING](#)
[MAINTENANCE](#)

6000-VFG-4-C

This tunnel unit is built up out of four single 6000-VFG inlets. This version is equipped with a curved inner valve that guides the air upwards during minimum ventilation. After opening further than 35% the air will also flow underneath the inner valve. This unit is controlled by two central arms per valve, which in turn, are connected with the other inner valves.



INFO

DATASHEET

ASSEMBLY

MOUNTING

WORKING

MAINTENANCE





6000-VFG-4-C DATASHEET



CAPACITY

Model	m ³ /h @ 10 Pa	m ³ /h @ 25 Pa	m ³ /h @ 40 Pa
6000-VFG-4-C	23200	35000	46400
	cfm @ 0.05 inH ₂ O	cfm @ 0.1 inH ₂ O	cfm @ 0.15 inH ₂ O
	15267	22986	26372

INFORMATION

Run	40 cm / 15.7 inch
Force	14 kg / 137.3 Newton
Number / pallet (1.65 x 0.95 x 2.40 m)	5
Weight / per inlet	42,5 kg / 93.7 lbs
Volume / per box	1
Arm position	3+

OPTIONAL ACCESSORIES

TPI-107 (*4)	Wire mesh synthetic
TPI-210c	Connection set
TPI-307 (*8)	Closing catch + spring
TPI-519 (*2)	Main cable support

AIR FLOW

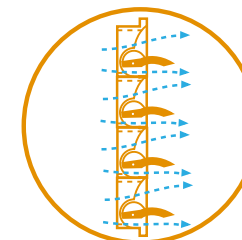
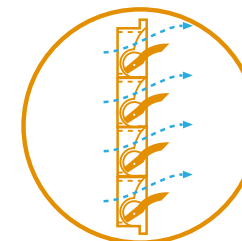

INFO

DATASHEET

ASSEMBLY

MOUNTING

WORKING

MAINTENANCE



6000-VFG-4-C ASSEMBLY

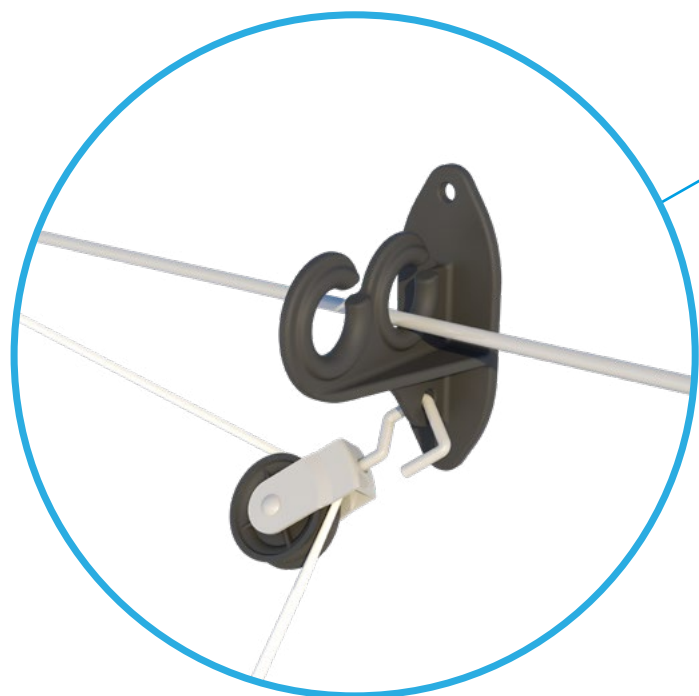

TPI-519

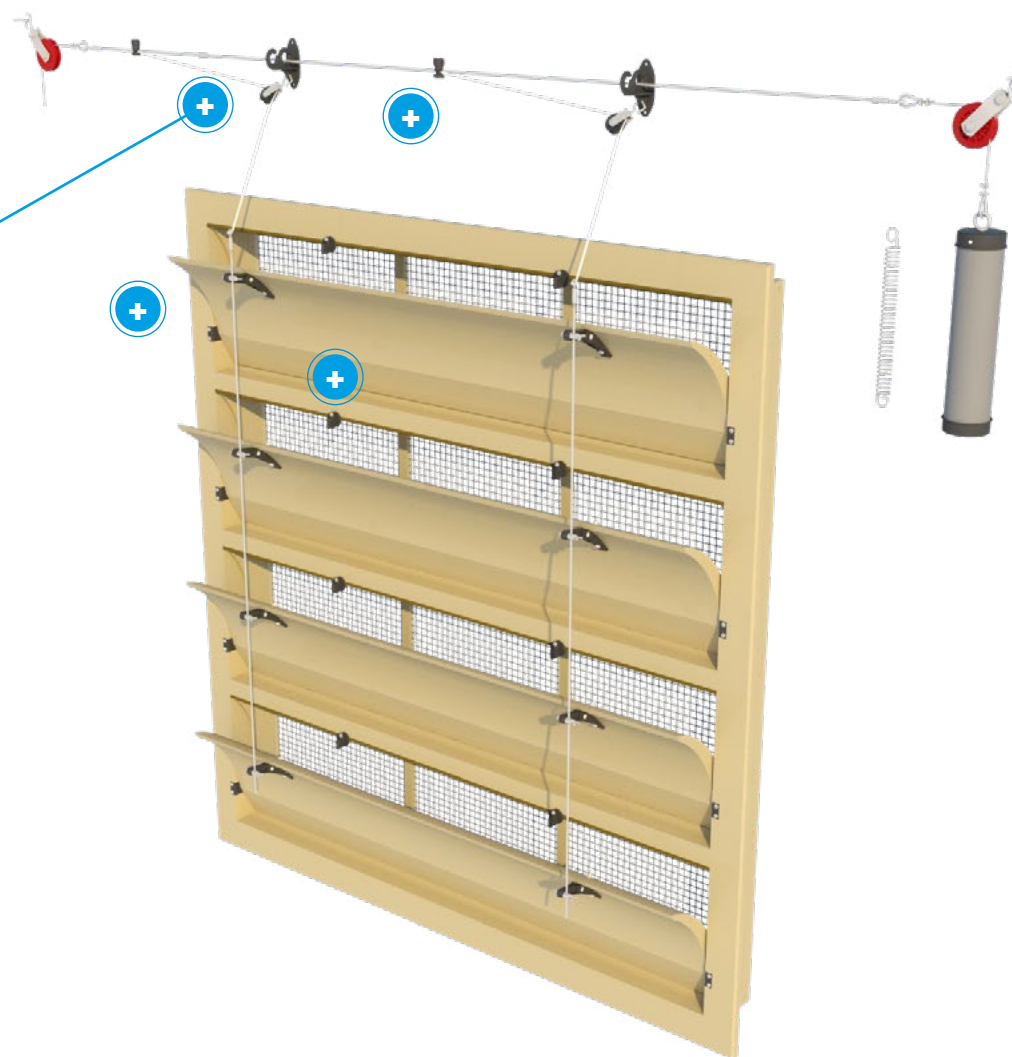

INFO

DATASHEET

ASSEMBLY

MOUNTING

WORKING

MAINTENANCE



6000-VFG-4-C ASSEMBLY



TPI-210C

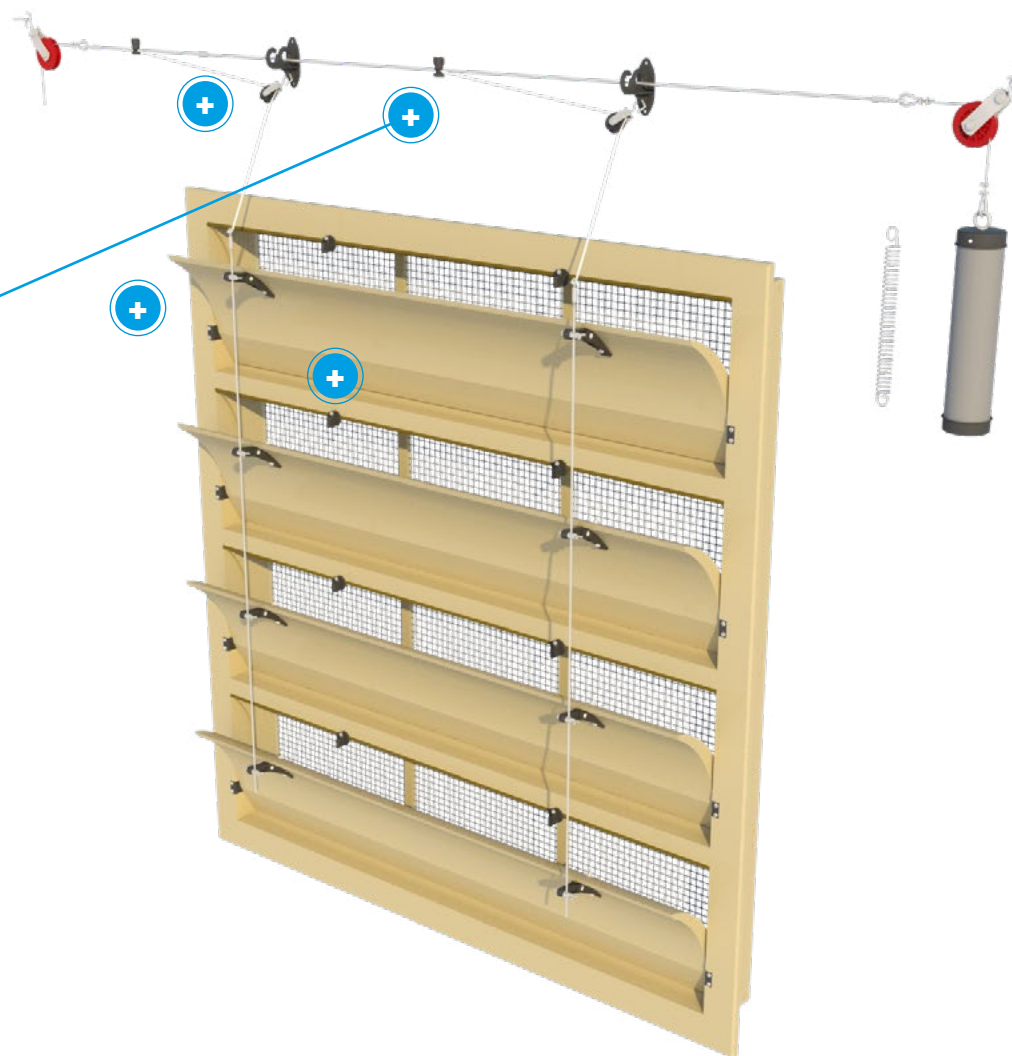

INFO

DATASHEET

ASSEMBLY

MOUNTING

WORKING

MAINTENANCE





6000-VFG-4-C ASSEMBLY

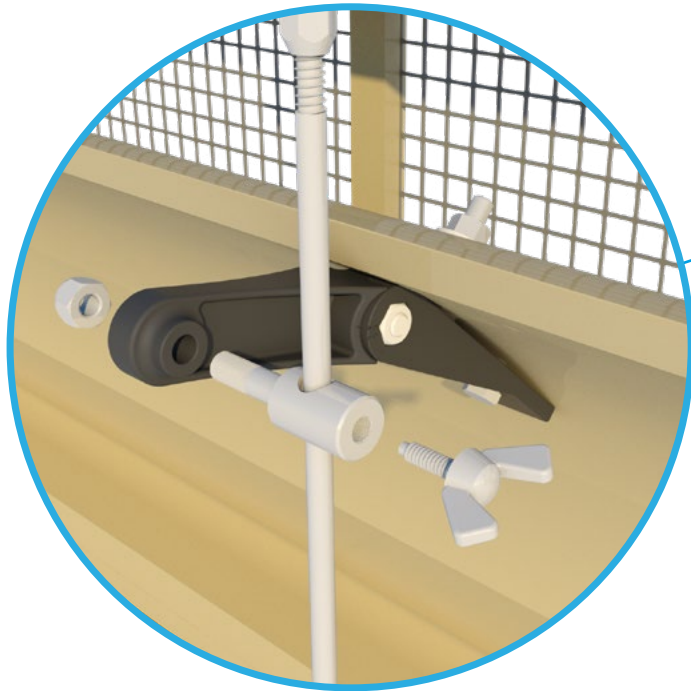

TPI-210C

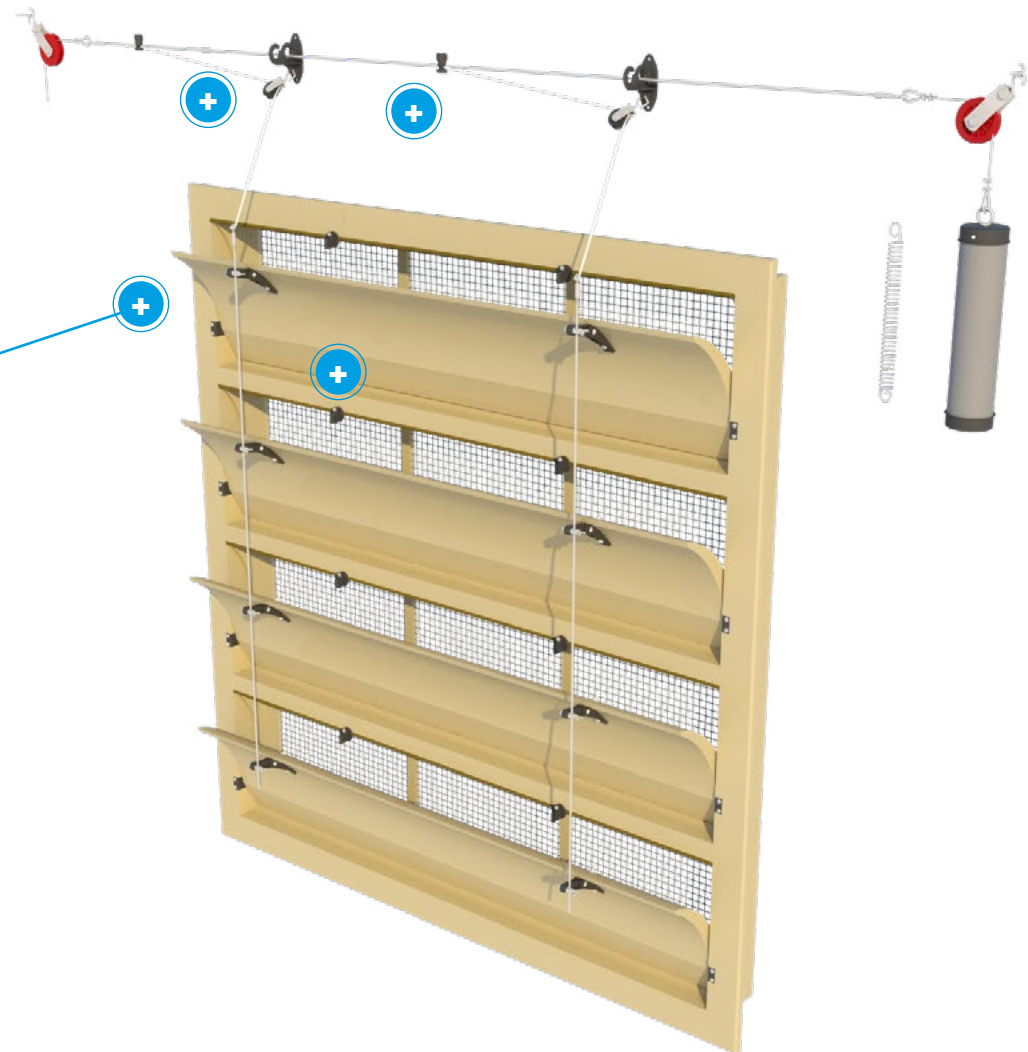

INFO

DATASHEET

ASSEMBLY

MOUNTING

WORKING

MAINTENANCE



6000-VFG-4-C ASSEMBLY

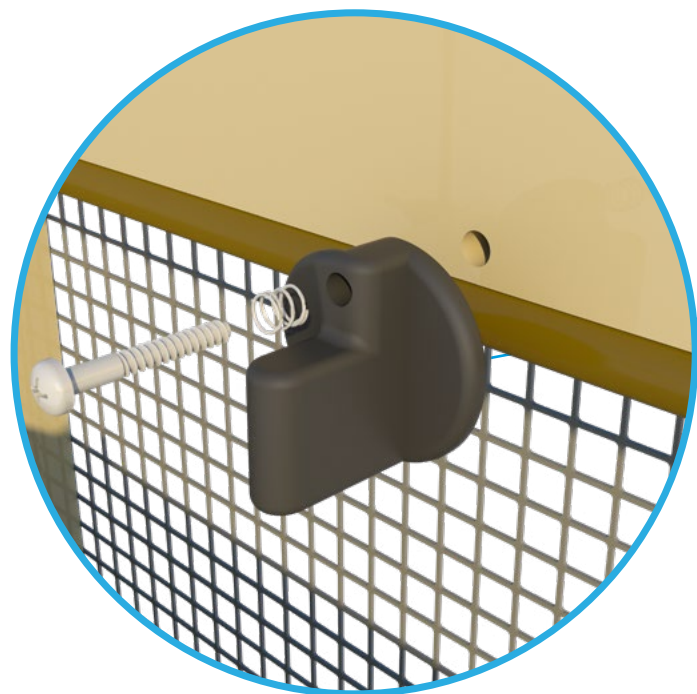

TPI-307

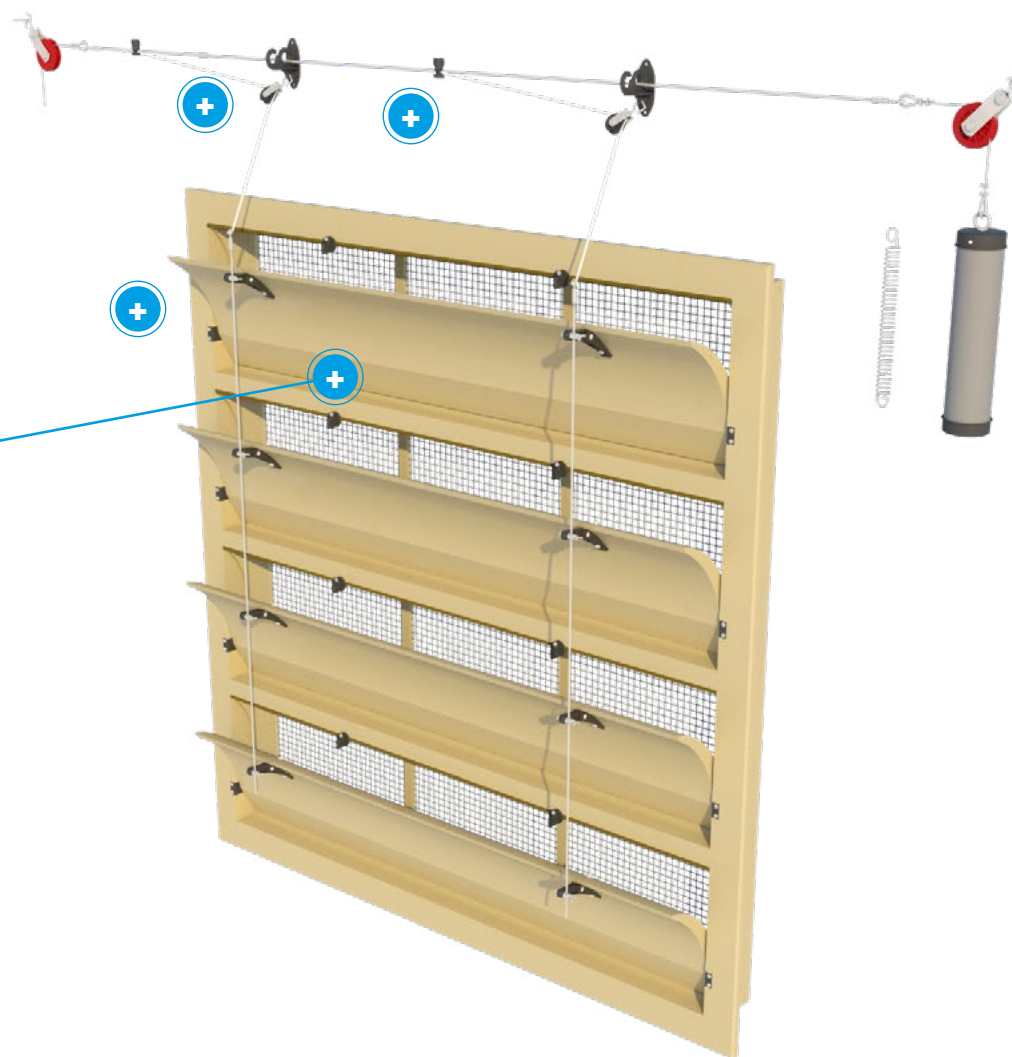

INFO

DATASHEET

ASSEMBLY

MOUNTING

WORKING

MAINTENANCE



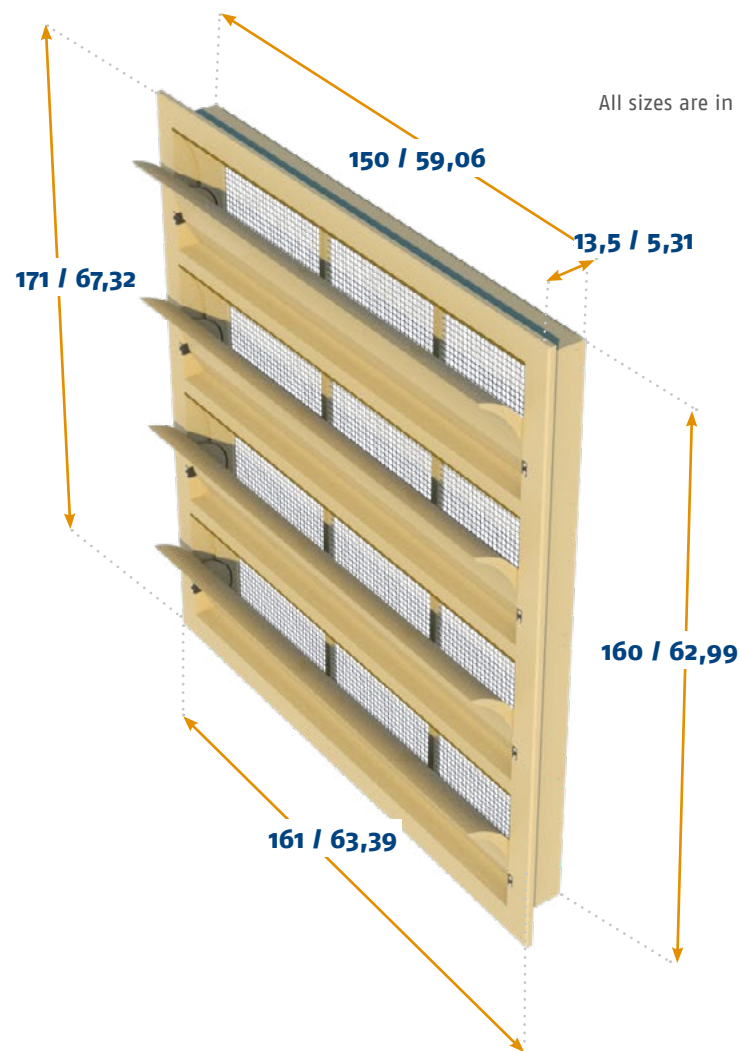
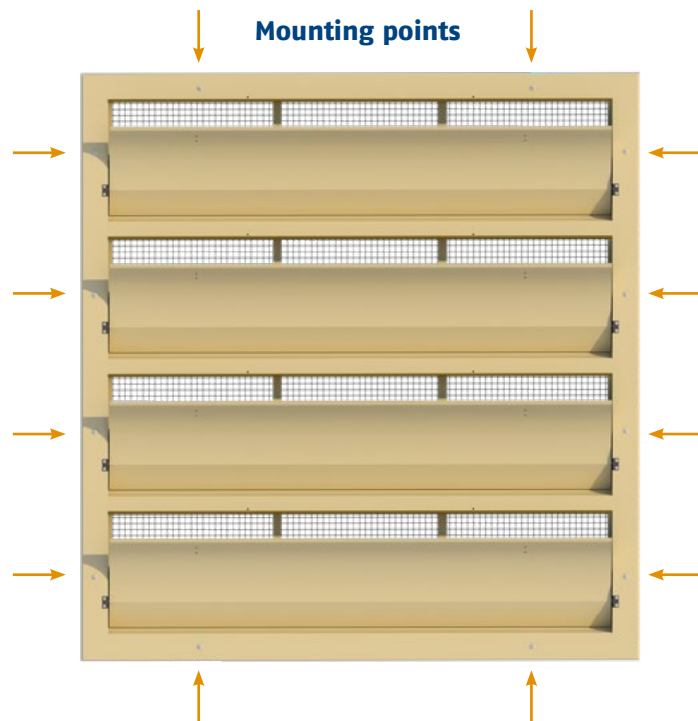

All sizes are in cm and inches

MOUNTING

Mounting type	Wall
Mounting hole size	152 cm / 59,84 inch x 162 cm / 63,78 inch

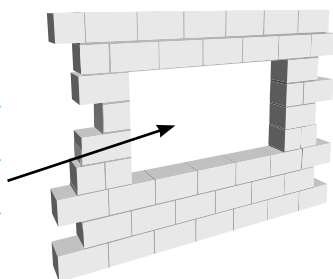

INFO

DATASHEET

ASSEMBLY

MOUNTING

WORKING

MAINTENANCE



AIR FLOW

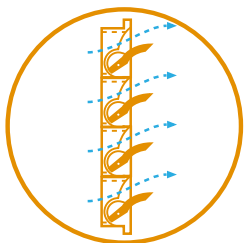

Middle hinged inlet

This middle hinged inlet is made to allow air to also flow underneath the inner flap after opening further than 35%. This helps to guide air downwards to the animals and provide a cooling effect during maximum ventilation.

Curved inner flap

This inlet is equipped with a curved inner flap. Curved flaps guide the air upwards during minimum ventilation, but also downwards after a certain point of opening. This is ideal for houses where air should be directed directly towards or over the animals during maximum ventilation.

Working with end-weights or springs

We offer two products which can be used to keep tension on the main cable. A PVC cylinder which can be filled with concrete or sand to act as end-weight, or a spring that holds tension on the cable.

Balanced set-up

When placing the motor winch or actuator we normally suggest to divide the inlets in two groups. It is preferable to place the winch or actuator in the middle to equally divide the forces on the main cable. (see ventilation concepts page for an example)

Use of closing catches

The closing catch on the inlet can be used to permanently close inlets for example during pre-heating. The closing catches can also be used to close certain inlets while continuing to use others. In that case the used inlets can be opened a bit further. In colder climates this can help to offer better resistance to freezing effects.

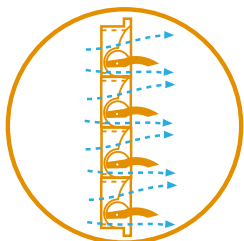
[INFO](#)
[DATASHEET](#)
[ASSEMBLY](#)
[MOUNTING](#)
[WORKING](#)
[MAINTENANCE](#)

6000-VFR-2

This tunnel unit is built up out of two single 6000-VFR inlets. This version is equipped with a straight inner valve that guides the air upwards during minimum ventilation. After opening further than 35% the air will also flow underneath the inner valve. This unit is controlled by side arms that connect the inner valves.



INFO

DATASHEET

ASSEMBLY

MOUNTING

WORKING

MAINTENANCE





6000-VFR-2 DATASHEET



CAPACITY

Model	m ³ /h @ 10 Pa	m ³ /h @ 25 Pa	m ³ /h @ 40 Pa
6000-VFR-2	11600	17500	23200
	cfm @ 0.05 inH ₂ O	cfm @ 0.1 inH ₂ O	cfm @ 0.15 inH ₂ O
	7633	11493	13186

INFORMATION

Run	17 cm / 6.7 inch
Force	7 kg / 69 Newton
Number / pallet (1.65 x 0.95 x 2.40 m)	10
Weight / per inlet	21,3 kg / 46.9 lbs
Volume / per box	2

OPTIONAL ACCESSORIES

TPI-107 (*2)	Wire mesh synthetic
TPI-208a	Connection set
TPI-307 (*4)	Closing catch + spring
TPI-519 (*2)	Main cable support

AIR FLOW

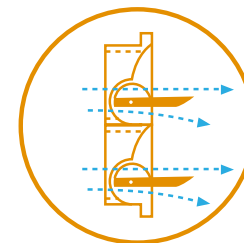
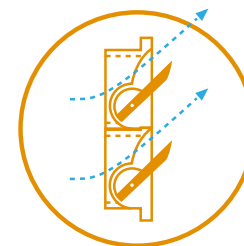

INFO

DATASHEET

ASSEMBLY

MOUNTING

WORKING

MAINTENANCE



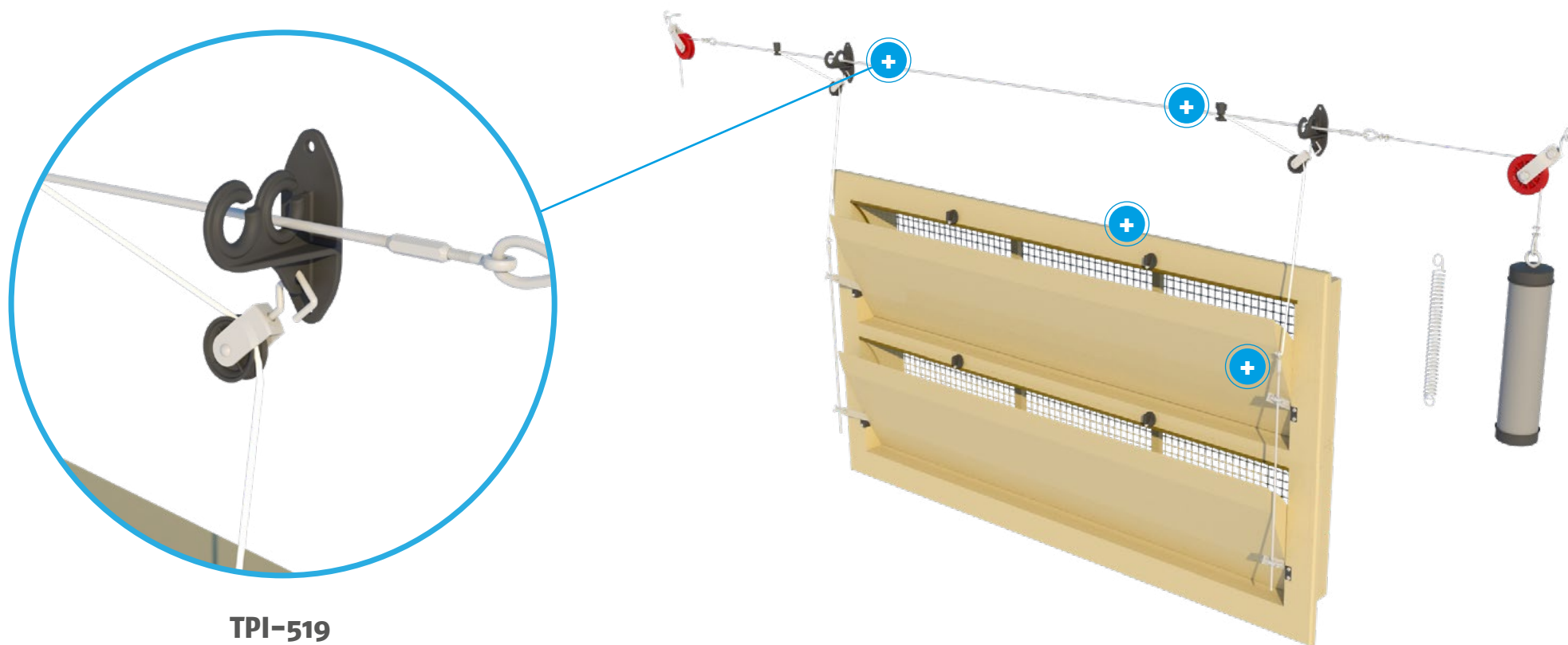

TPI-519

INFO

DATASHEET

ASSEMBLY

MOUNTING

WORKING

MAINTENANCE



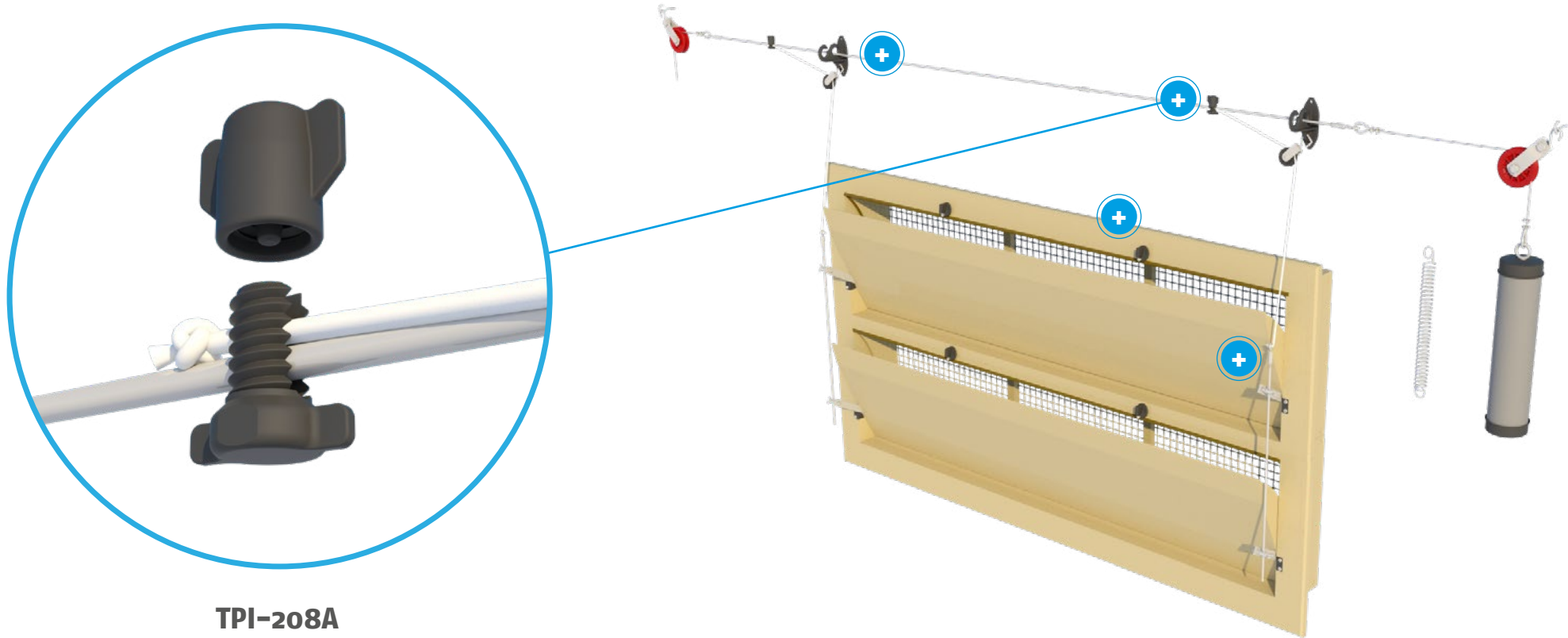

TPI-208A

INFO

DATASHEET

ASSEMBLY

MOUNTING

WORKING

MAINTENANCE



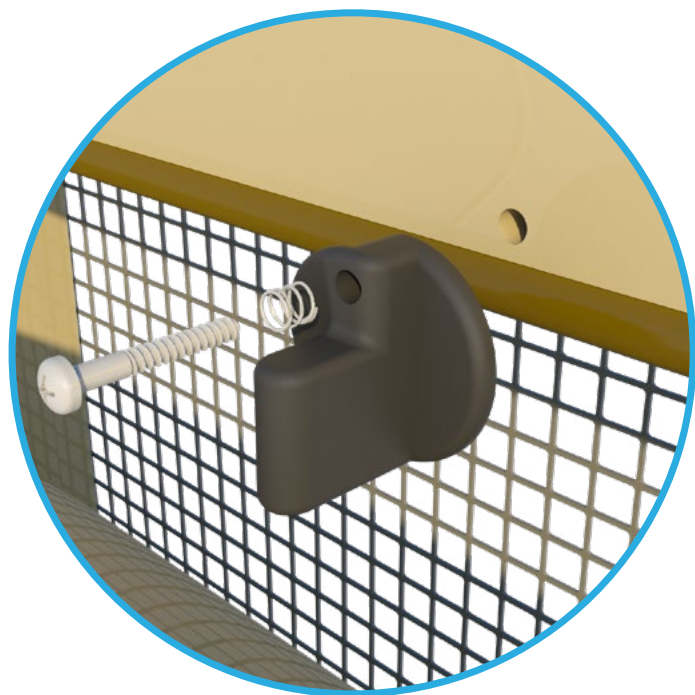

TPI-307

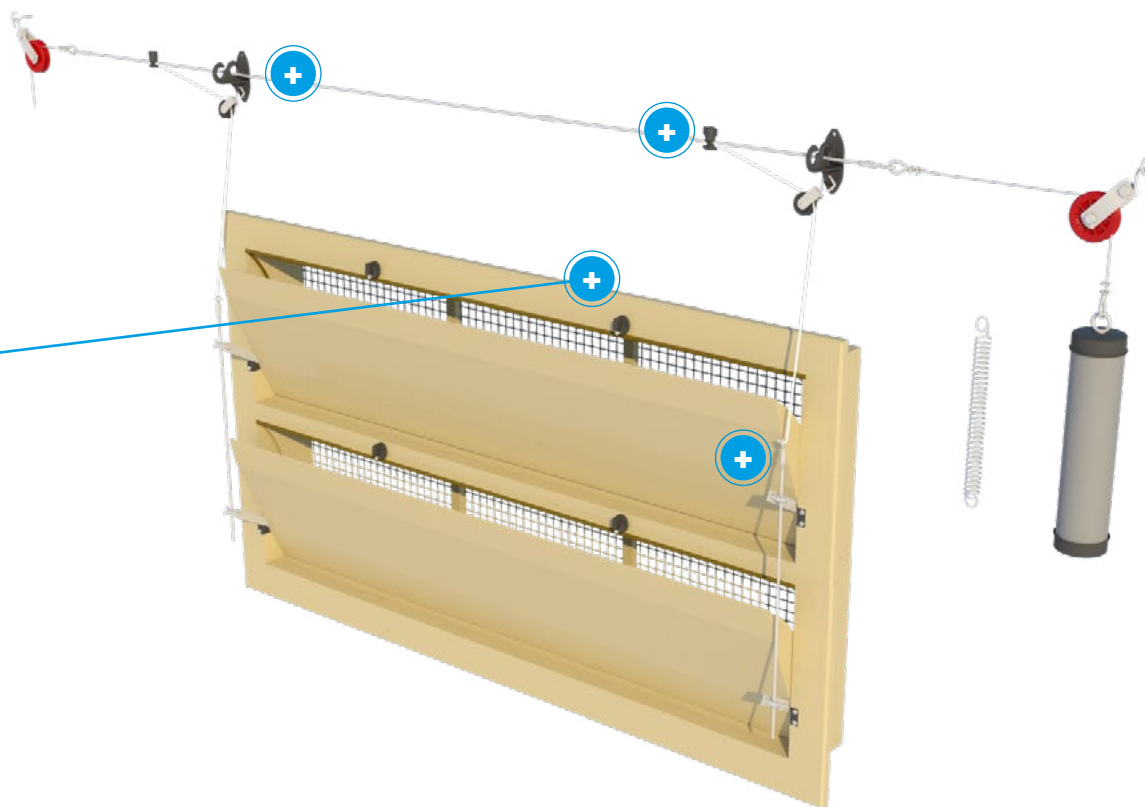

INFO

DATASHEET

ASSEMBLY

MOUNTING

WORKING

MAINTENANCE



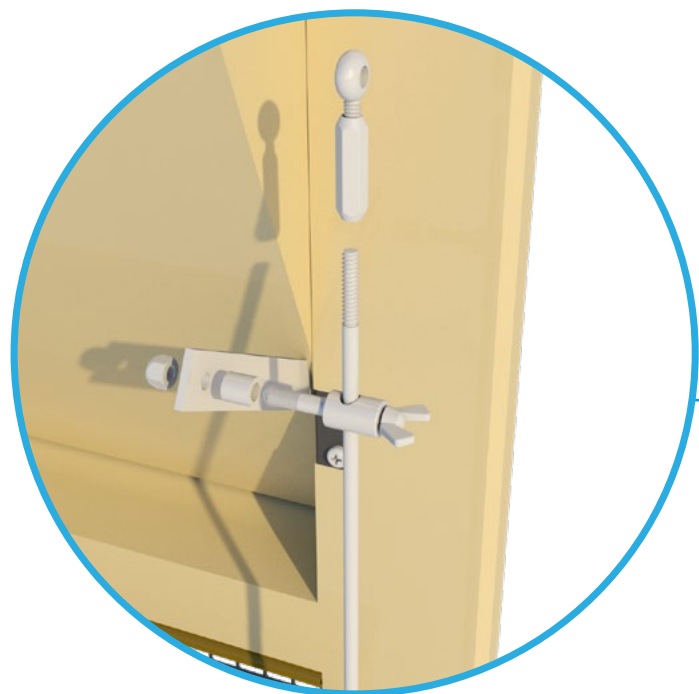

TPI-208A

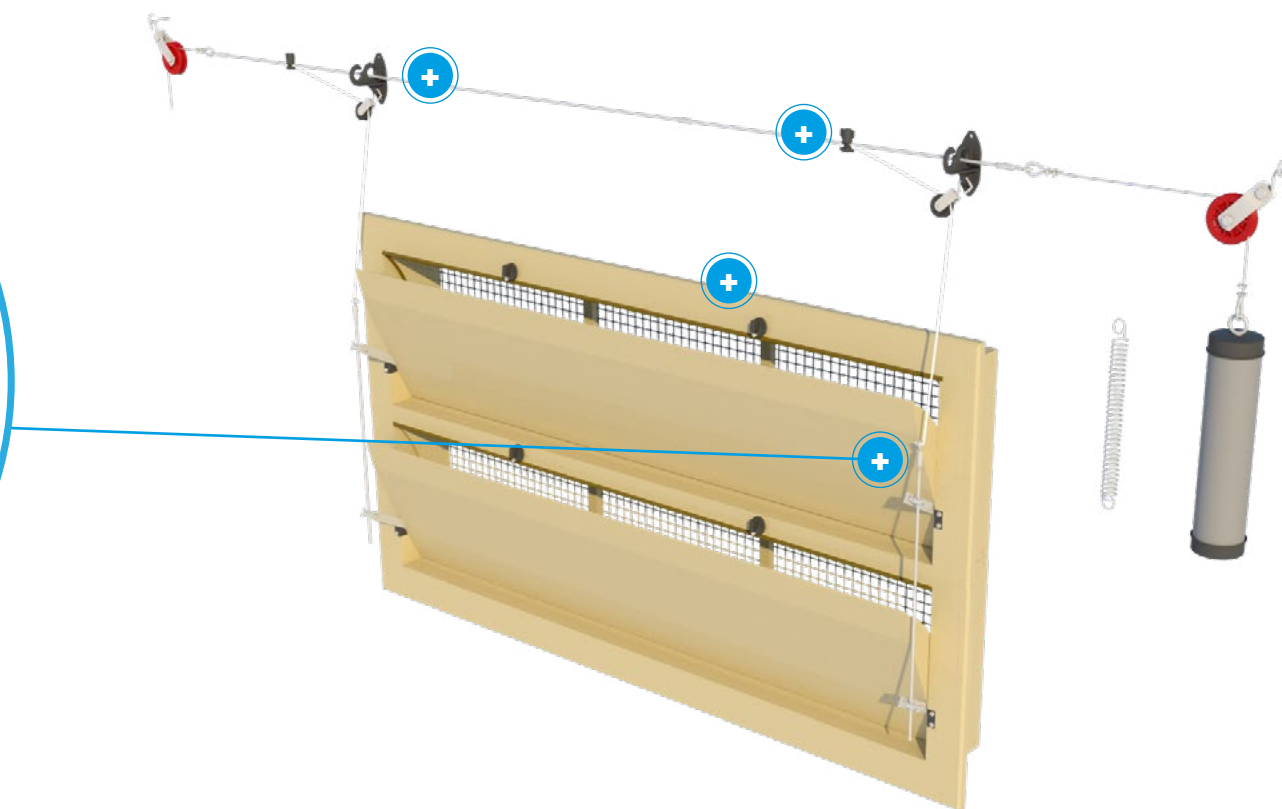

INFO

DATASHEET

ASSEMBLY

MOUNTING

WORKING

MAINTENANCE



All sizes are in cm and inches

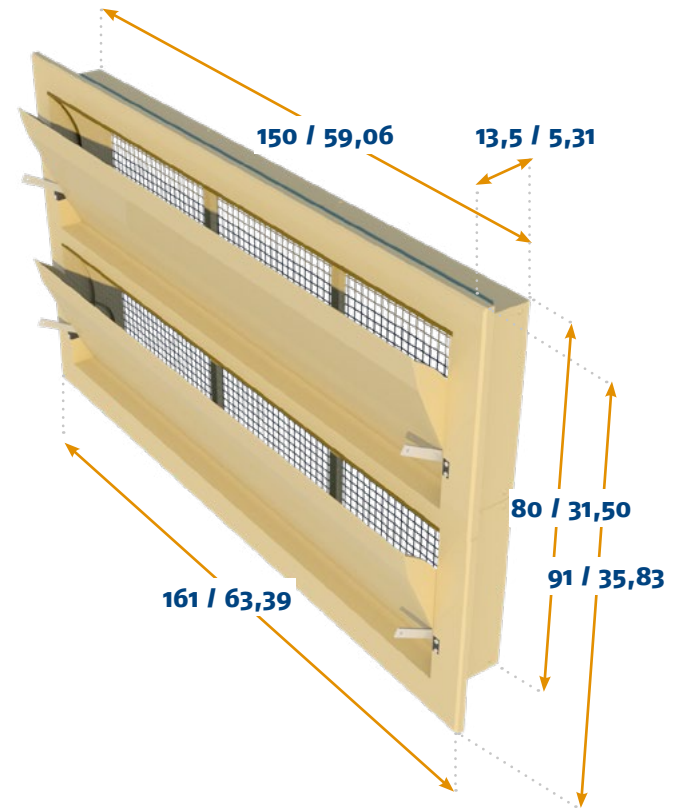
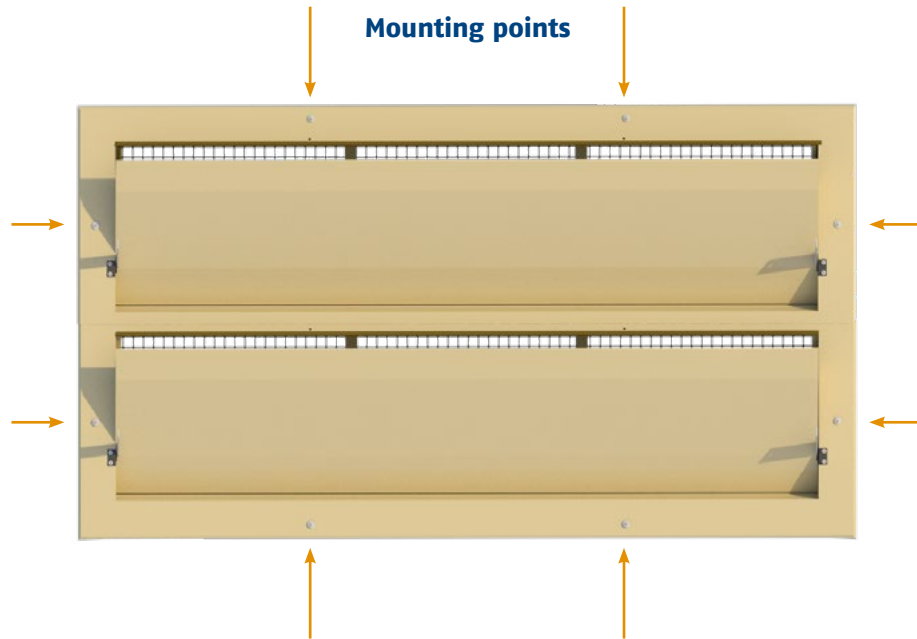

MOUNTING

Mounting type	Wall
Mounting hole size	152 cm / 59,84 inch x 82 cm / 32,28 inch

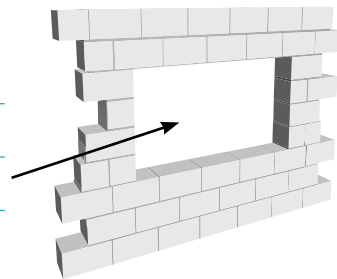

INFO

DATASHEET

ASSEMBLY

MOUNTING

WORKING

MAINTENANCE



AIR FLOW

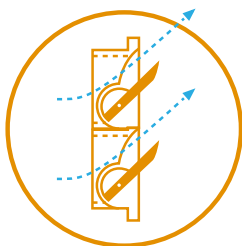

Middle hinged inlet

This middle hinged inlet is made to allow air to also flow underneath the inner flap after opening further than 35%. This helps to guide air downwards to the animals and provide a cooling effect during maximum ventilation.

Straight inner flap

This inlet is equipped with a straight inner flap. Straight flaps guide air in a straight upwards or horizontal direction, never downwards. This is ideal for houses where air should not be directed directly towards or over the animals during maximum ventilation.

Working with end-weights or springs

We offer two products which can be used to keep tension on the main cable. A PVC cylinder which can be filled with concrete or sand to act as end-weight, or a spring that holds tension on the cable.

Balanced set-up

When placing the motor winch or actuator we normally suggest to divide the inlets in two groups. It is preferable to place the winch or actuator in the middle to equally divide the forces on the main cable.

(see ventilation concepts page for an example)

Use of closing catches

The closing catch on the inlet can be used to permanently close inlets for example during pre-heating. The closing catches can also be used to close certain inlets while continuing to use others. In that case the used inlets can be opened a bit further. In colder climates this can help to offer better resistance to freezing effects.



INFO

DATASHEET

ASSEMBLY

MOUNTING

WORKING

MAINTENANCE



6000-VFR-2-C

This tunnel unit is built up out of two single 6000-VFR inlets. This version is equipped with a straight inner valve that guides the air upwards during minimum ventilation. After opening further than 35% the air will also flow underneath the inner valve. This unit is controlled by two central arms per valve, which in turn, are connected with the other inner valves.

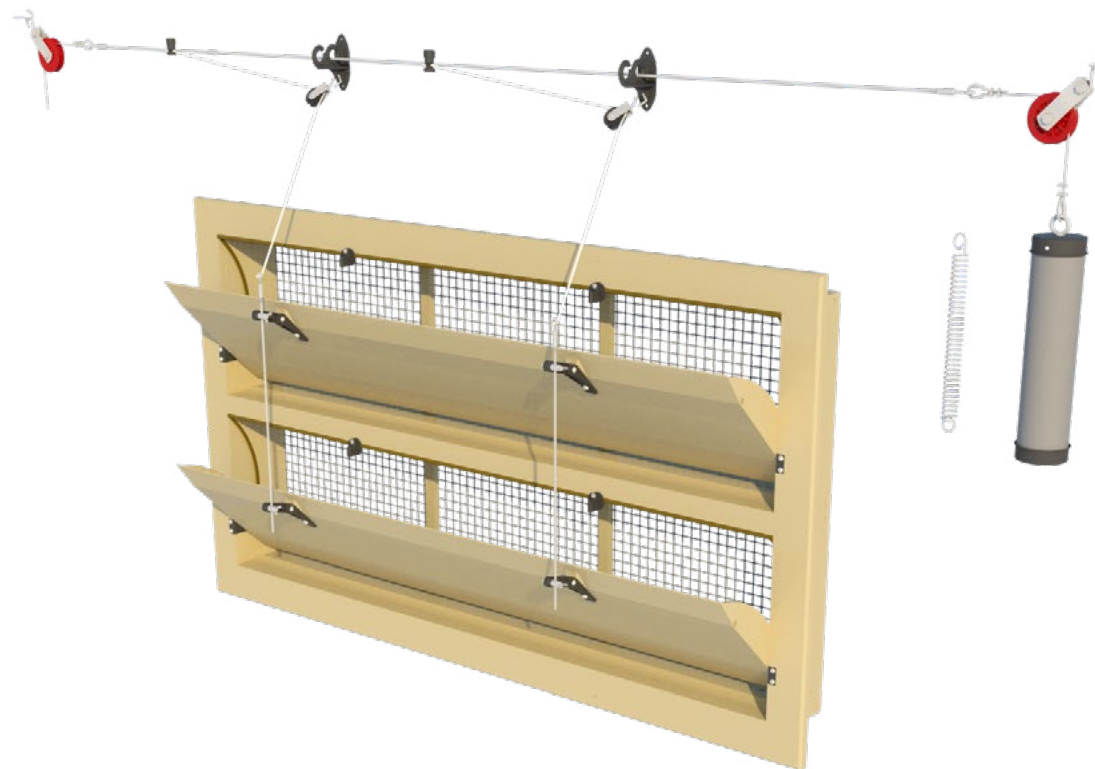

INFO

DATASHEET

ASSEMBLY

MOUNTING

WORKING

MAINTENANCE





6000-VFR-2-C DATASHEET



CAPACITY

Model	m ³ /h @ 10 Pa	m ³ /h @ 25 Pa	m ³ /h @ 40 Pa
6000-VFR-2-C	11600	17500	23200
	cfm @ 0.05 inH ₂ O	cfm @ 0.1 inH ₂ O	cfm @ 0.15 inH ₂ O
	7633	11493	13186

INFORMATION

Run	37 cm / 14.6 inch
Force	7 kg / 68.6 Newton
Number / pallet (1.65 x 0.95 x 2.40 m)	10
Weight / per inlet	21,3 kg / 46.9 lbs
Volume / per box	2
Arm position	3+

OPTIONAL ACCESSORIES

TPI-107 (*2)	Wire mesh synthetic
TPI-208c	Connection set
TPI-307 (*4)	Closing catch + spring
TPI-519 (*2)	Main cable support

AIR FLOW

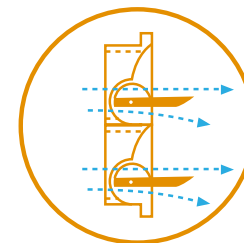
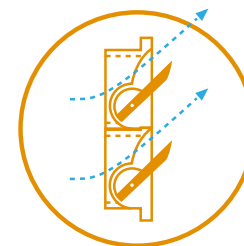

INFO

DATASHEET

ASSEMBLY

MOUNTING

WORKING

MAINTENANCE



6000-VFR-2-C ASSEMBLY

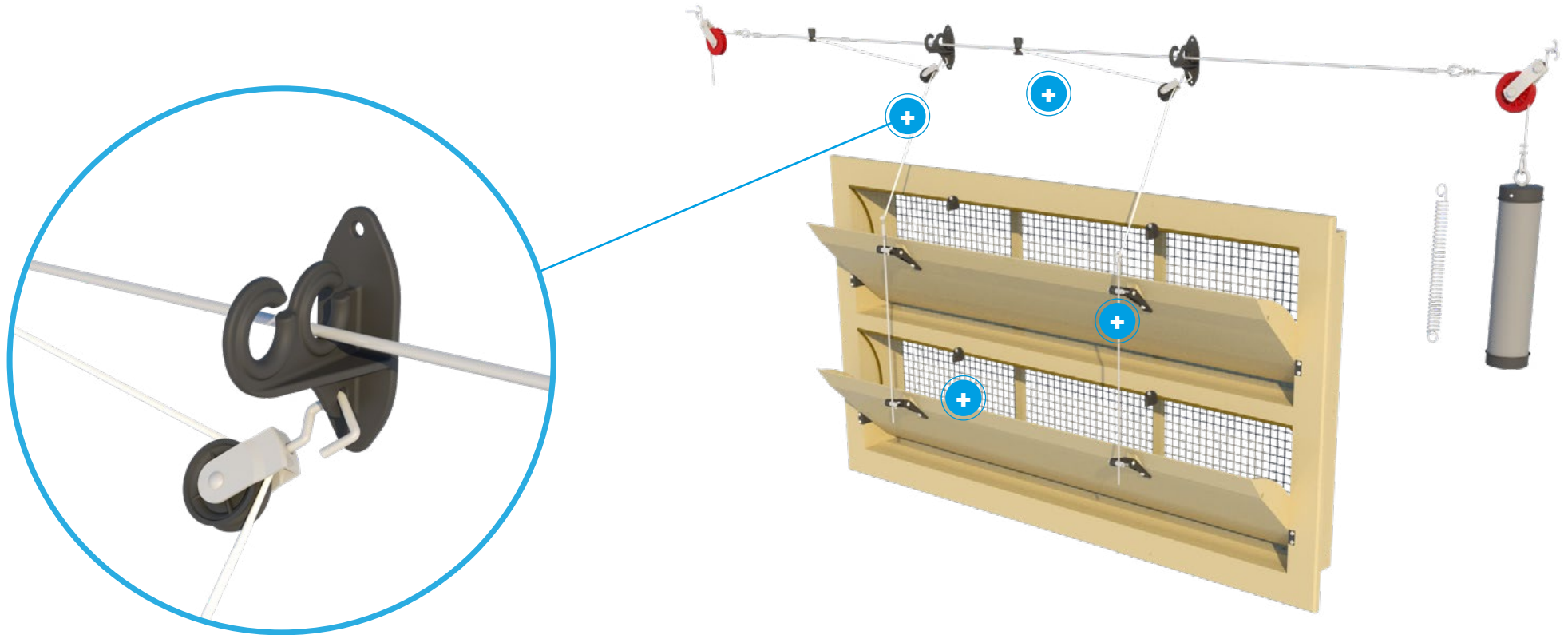

TPI-519

INFO

DATASHEET

ASSEMBLY

MOUNTING

WORKING

MAINTENANCE



6000-VFR-2-C ASSEMBLY



TPI-208c

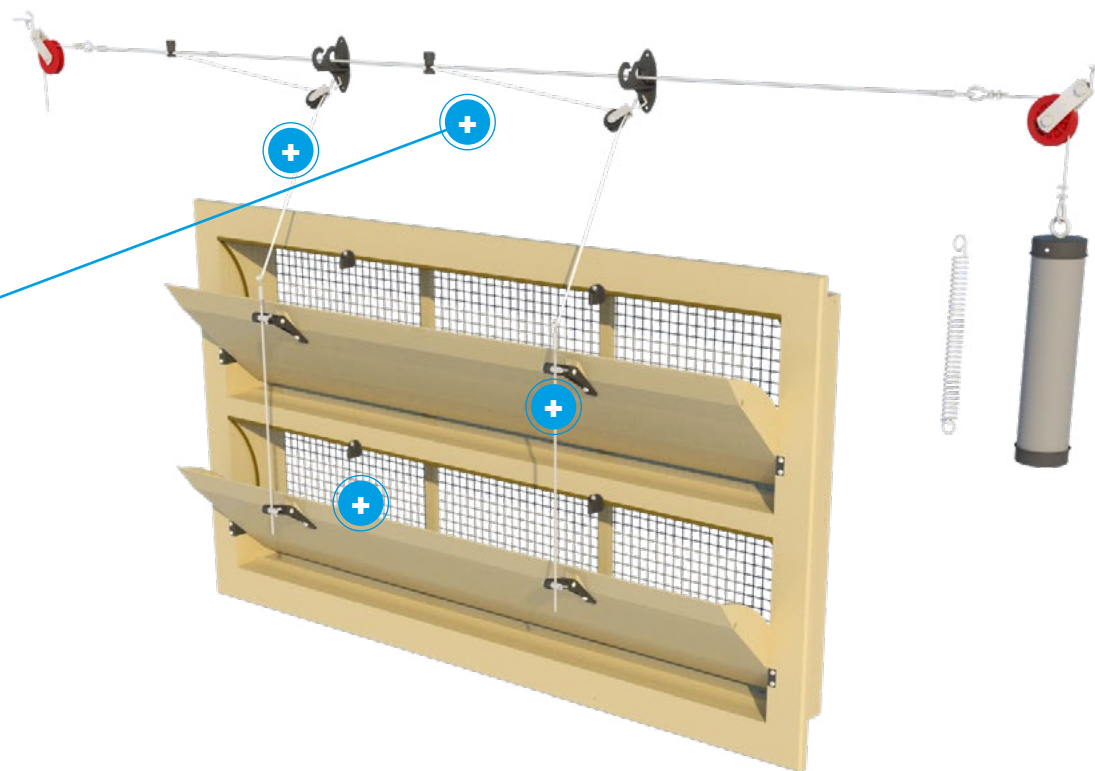

INFO

DATASHEET

ASSEMBLY

MOUNTING

WORKING

MAINTENANCE



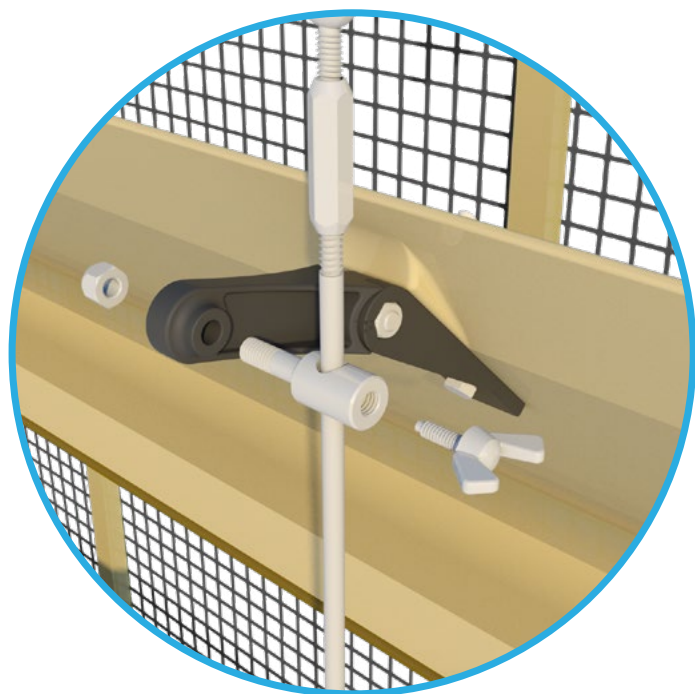

TPI-208c

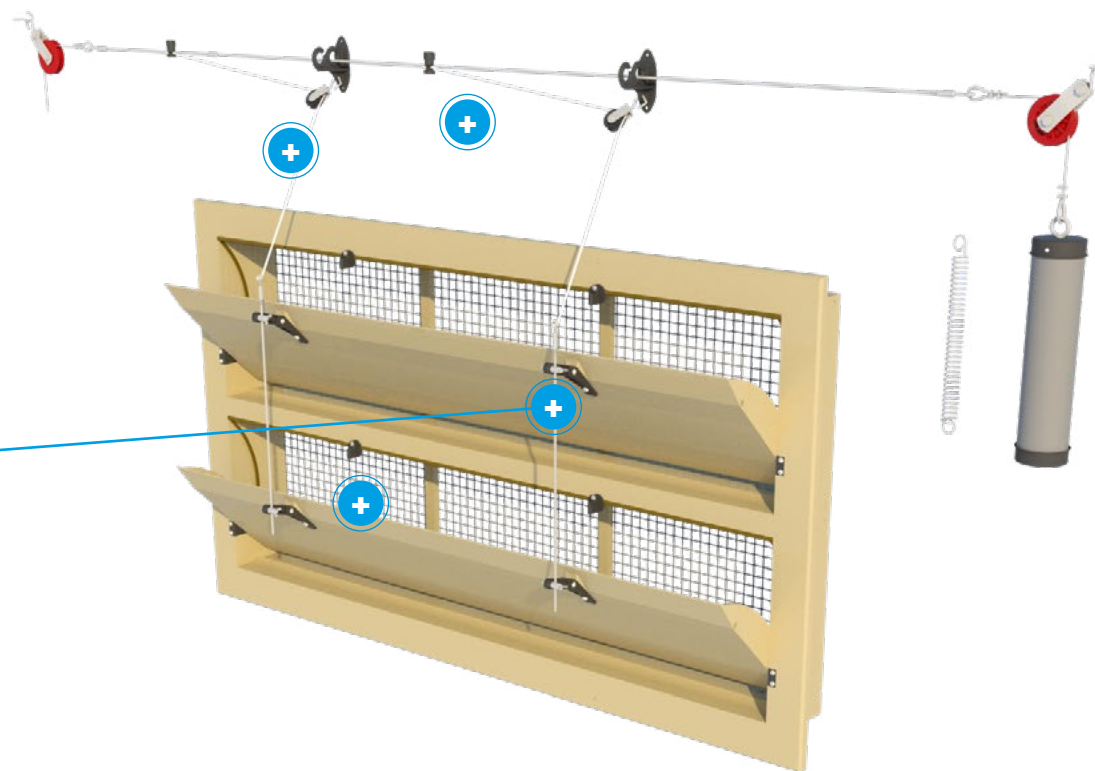

INFO

DATASHEET

ASSEMBLY

MOUNTING

WORKING

MAINTENANCE



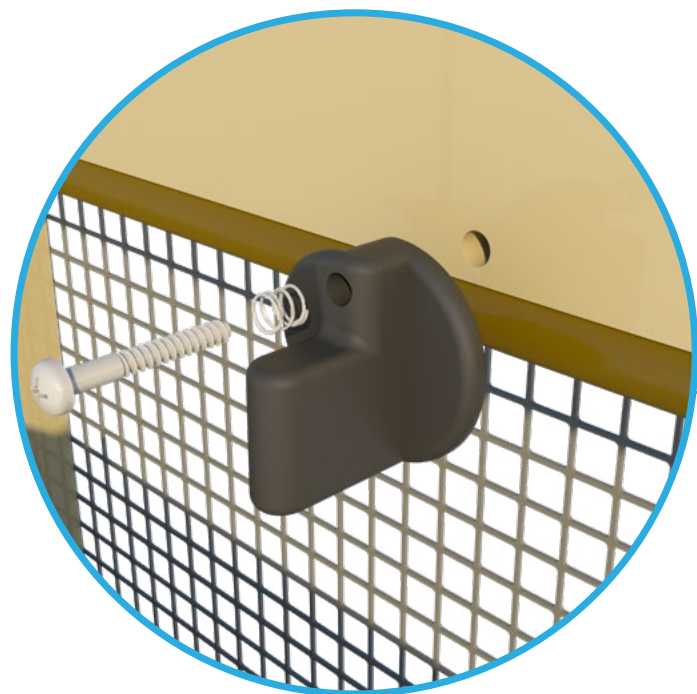

TPI-307

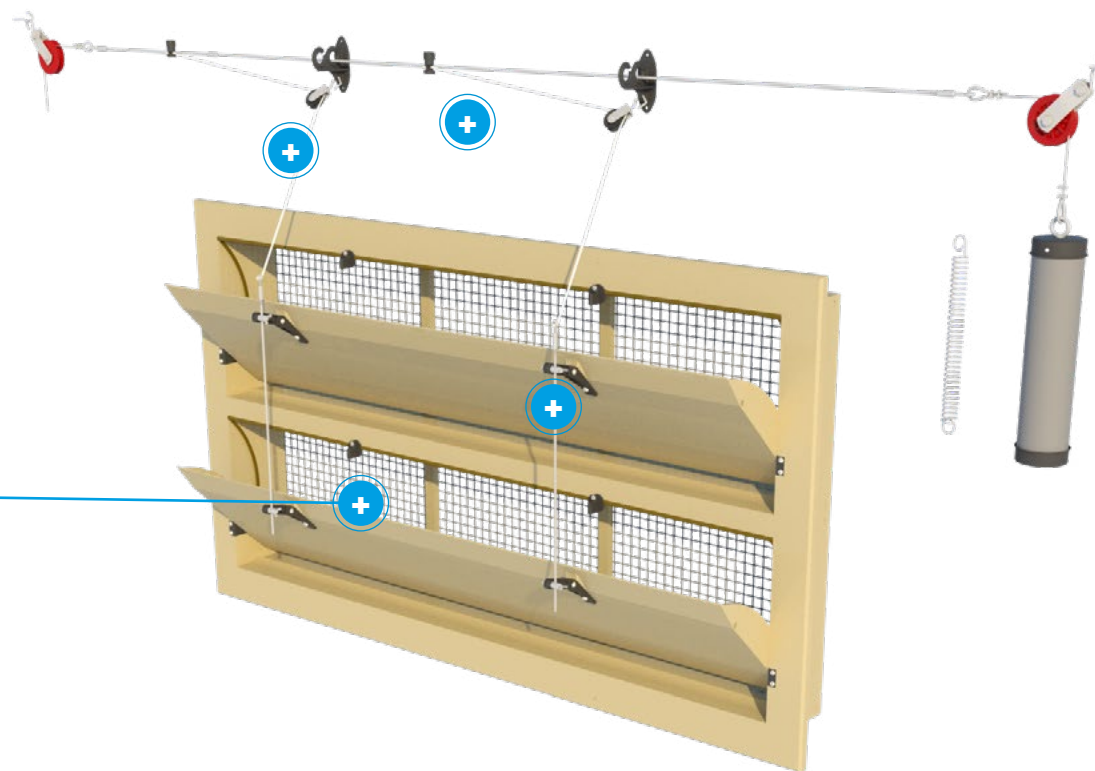

INFO

DATASHEET

ASSEMBLY

MOUNTING

WORKING

MAINTENANCE



All sizes are in cm and inches

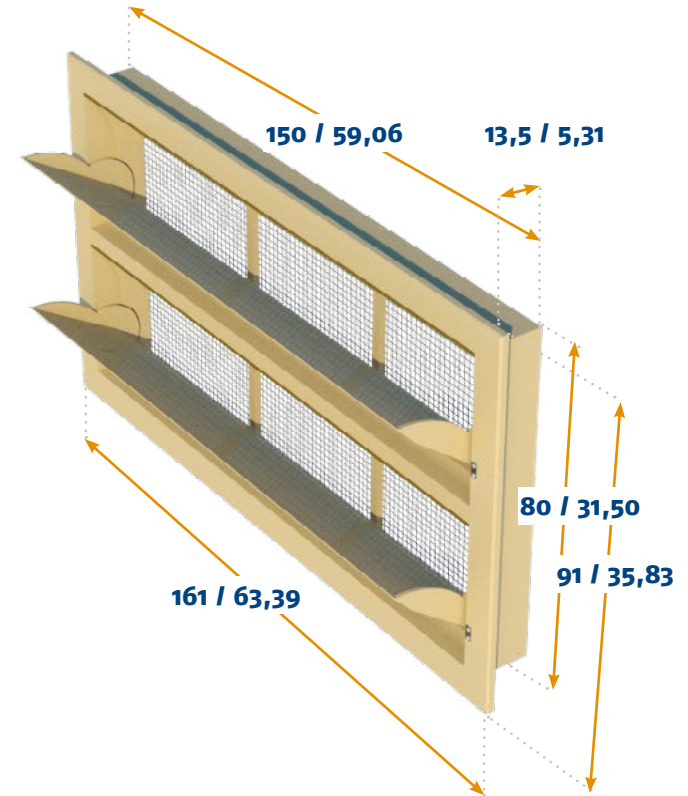
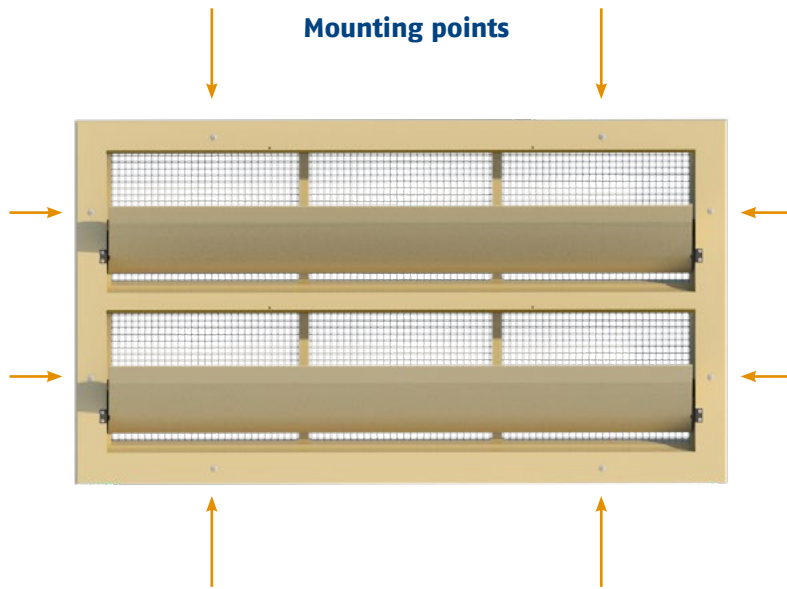

MOUNTING

Mounting type	Wall
Mounting hole size	152 cm / 59,84 inch x 82 cm / 32,28 inch

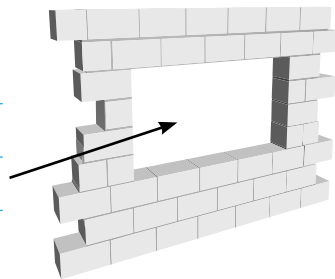

INFO

DATASHEET

ASSEMBLY

MOUNTING

WORKING

MAINTENANCE



AIR FLOW

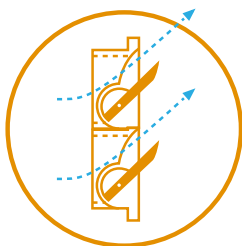

Middle hinged inlet

This middle hinged inlet is made to allow air to also flow underneath the inner flap after opening further then 35%. This helps to guide air downwards to the animals and provide a cooling effect during maximum ventilation.

Straight inner flap

This inlet is equipped with a straight inner flap. Straight flaps guide air in a straight upwards or horizontal direction, never downwards. This is ideal for houses where air should not be directed directly towards or over the animals during maximum ventilation.

Working with end-weights or springs

We offer two products which can be used to keep tension on the main cable. A PVC cylinder which can be filled with concrete or sand to act as end-weight, or a spring that holds tension on the cable.

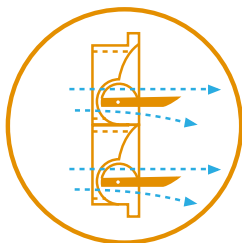

Balanced set-up

When placing the motor winch or actuator we normally suggest to divide the inlets in two groups. It is preferable to place the winch or actuator in the middle to equally divide the forces on the main cable.

(see ventilation concepts page for an example)

Use of closing catches

The closing catch on the inlet can be used to permanently close inlets for example during pre-heating. The closing catches can also be used to close certain inlets while continuing to use others. In that case the used inlets can be opened a bit further. In colder climates this can help to offer better resistance to freezing effects.



INFO

DATASHEET

ASSEMBLY

MOUNTING

WORKING

MAINTENANCE



6000-VFR-3

This tunnel unit is built up out of three single 6000-VFR inlets. This version is equipped with a straight inner valve that guides the air upwards during minimum ventilation. After opening further than 35% the air will also flow underneath the inner valve. This unit is controlled by side arms that connect the inner valves.



INFO

DATASHEET

ASSEMBLY

MOUNTING

WORKING

MAINTENANCE





6000-VFR-3 DATASHEET



CAPACITY

Model	m ³ /h @ 10 Pa	m ³ /h @ 25 Pa	m ³ /h @ 40 Pa
6000-VFR-3	17400	26250	34800
	cfm @ 0.05 inH ₂ O	cfm @ 0.1 inH ₂ O	cfm @ 0.15 inH ₂ O
	11450	17239	19779

INFORMATION

Run	17 cm / 6.7 inch
Force	27 kg / 264 Newton
Number / pallet (1.65 x 0.95 x 2.40 m)	5
Weight / per inlet	31,9 kg / 70.3 lbs
Volume / per box	1

OPTIONAL ACCESSORIES

TPI-107 (*3)	Wire mesh synthetic
TPI-209a	Connection set
TPI-307 (*6)	Closing catch + spring
TPI-519 (*2)	Main cable support

AIR FLOW

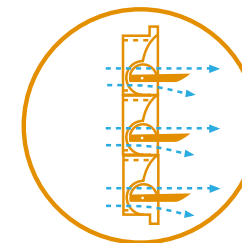
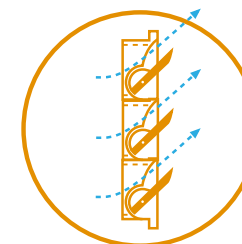

INFO

DATASHEET

ASSEMBLY

MOUNTING

WORKING

MAINTENANCE



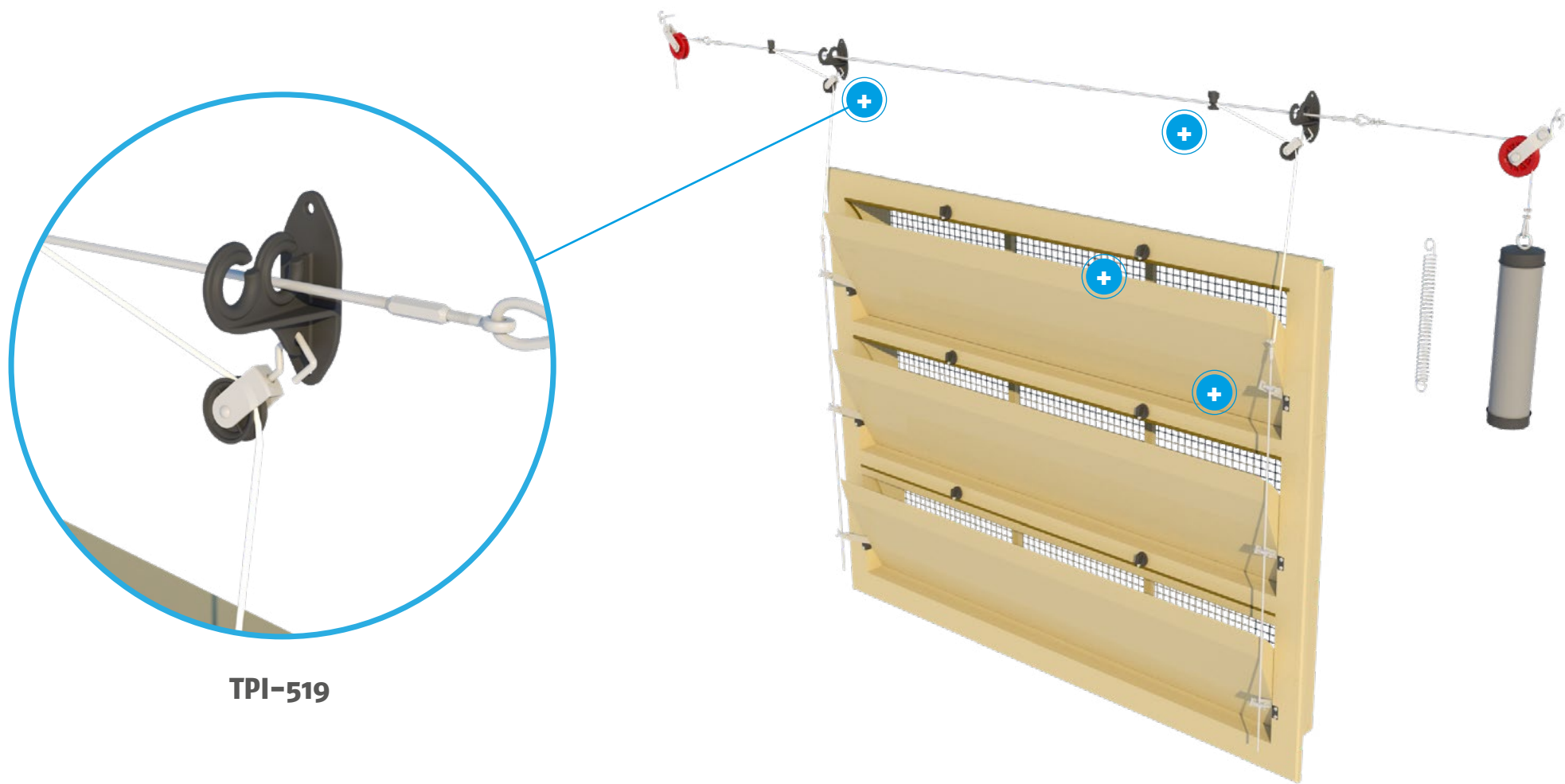

TPI-519



TPI-209A

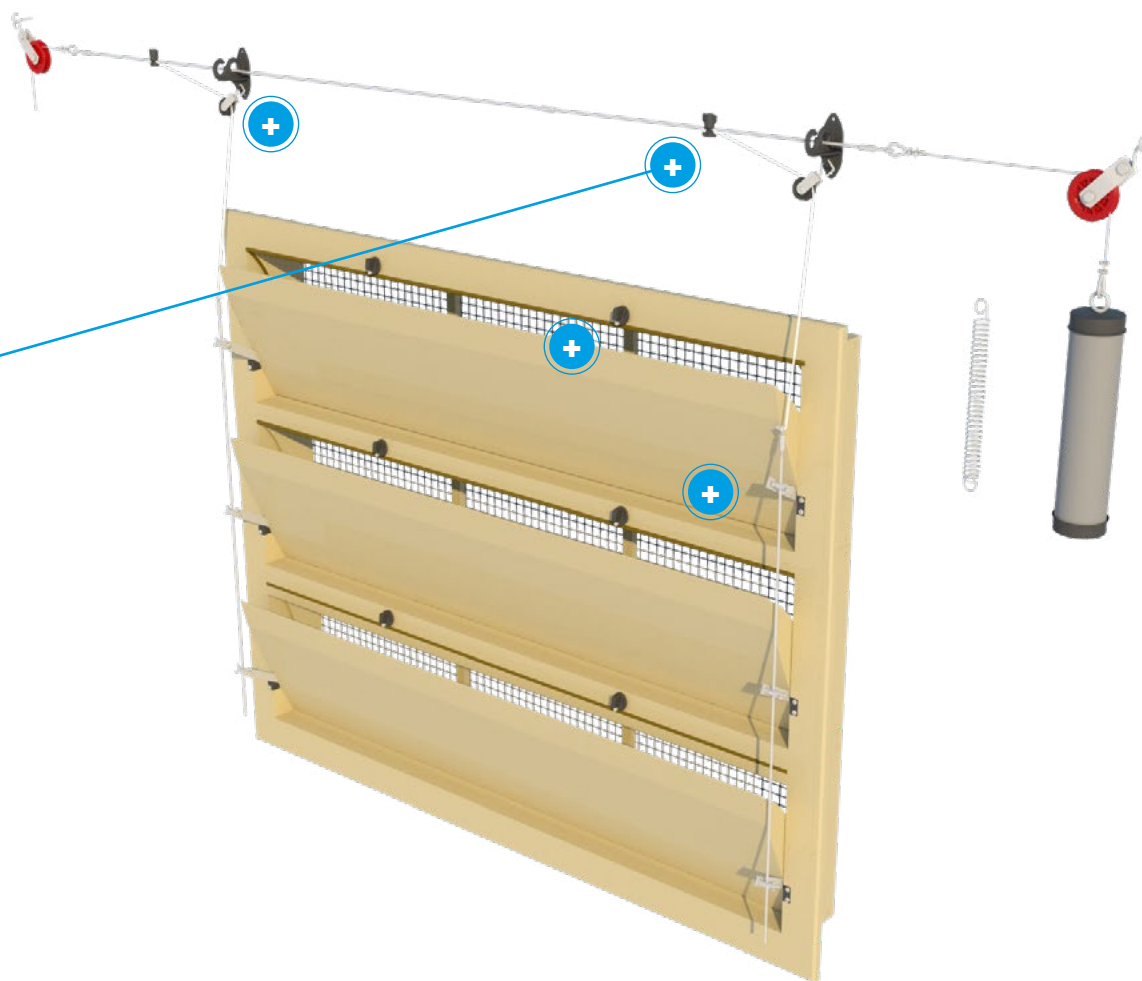

[INFO](#)

[DATASHEET](#)

[ASSEMBLY](#)

[MOUNTING](#)

[WORKING](#)

[MAINTENANCE](#)



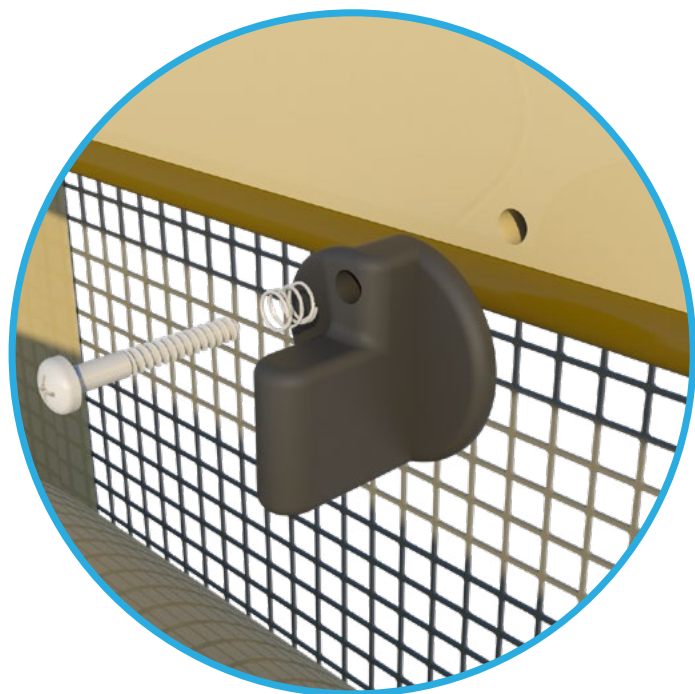

TPI-307

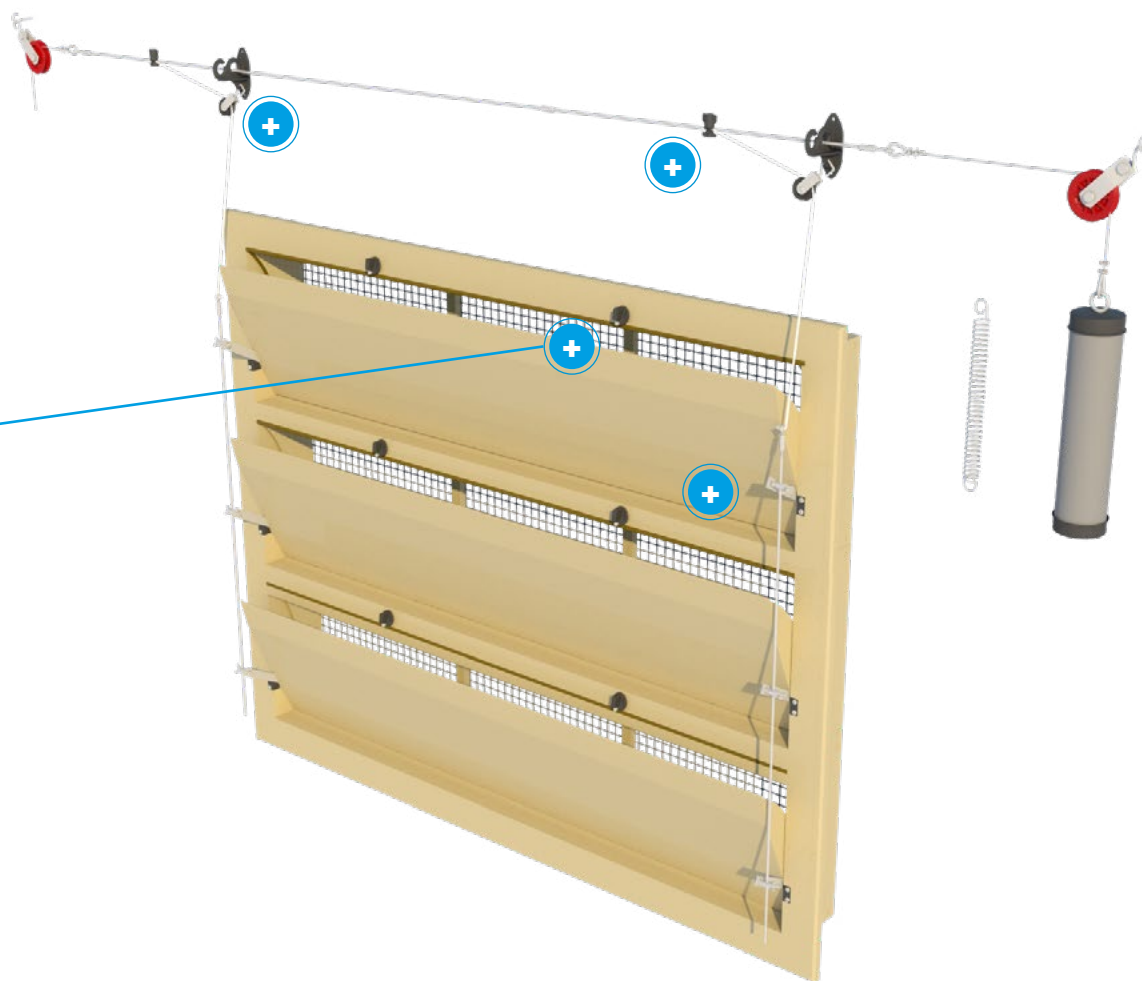

[INFO](#)

[DATASHEET](#)

[ASSEMBLY](#)

[MOUNTING](#)

[WORKING](#)

[MAINTENANCE](#)



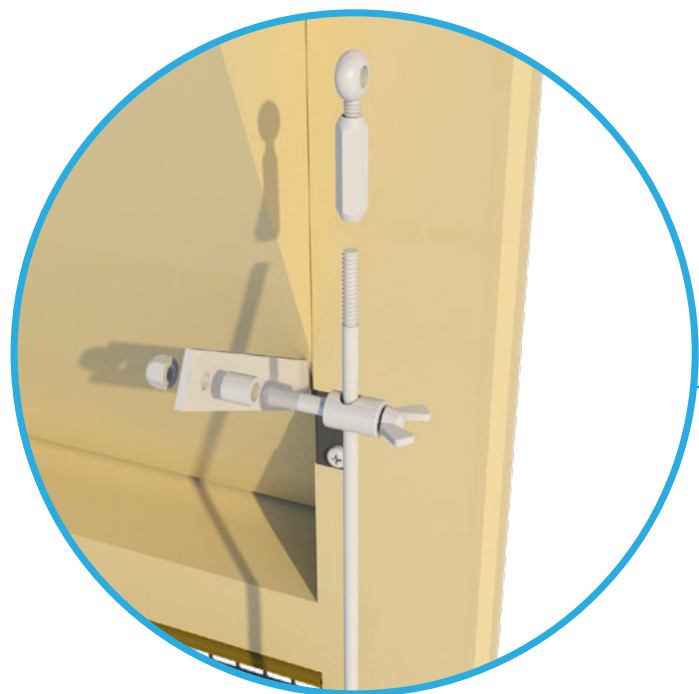

TPI-209A

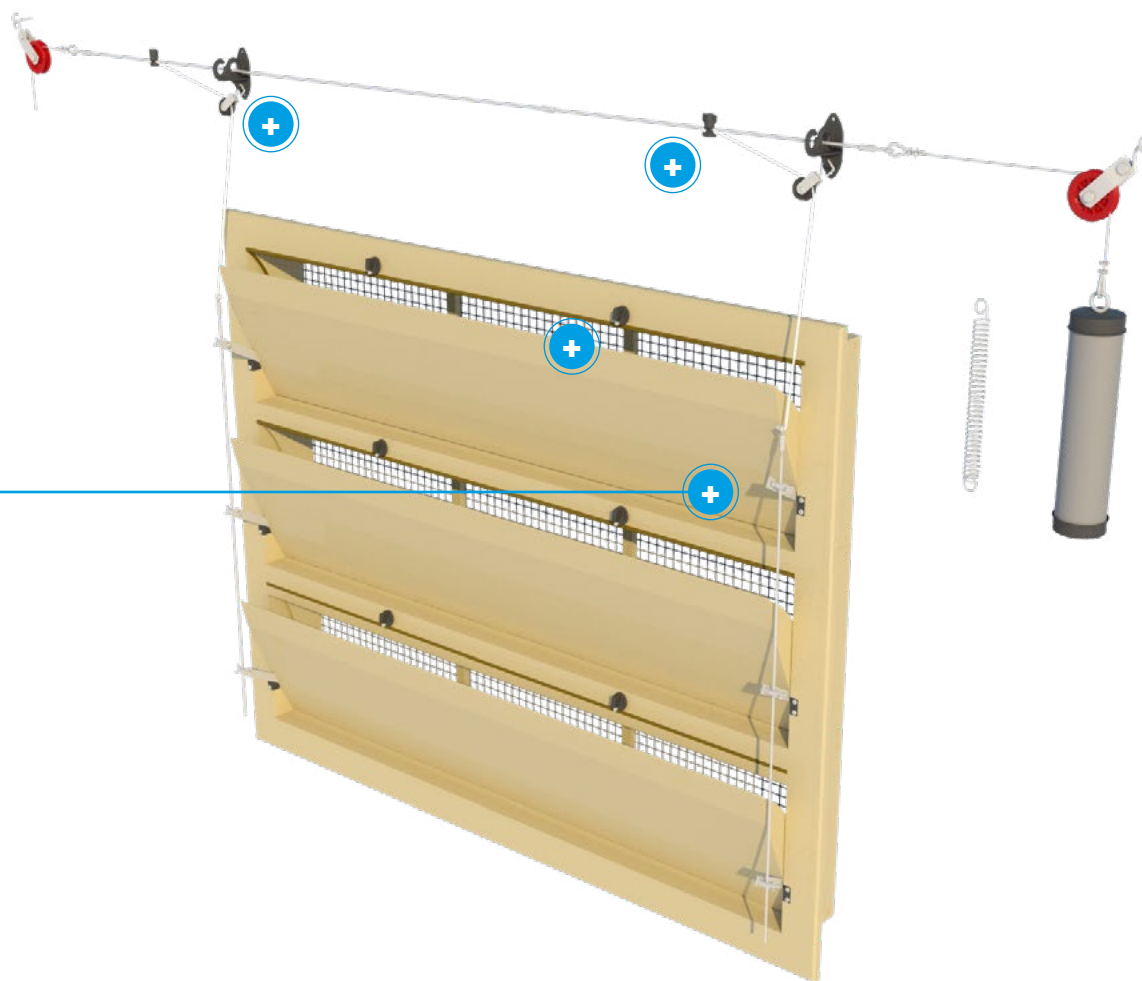

INFO

DATASHEET

ASSEMBLY

MOUNTING

WORKING

MAINTENANCE



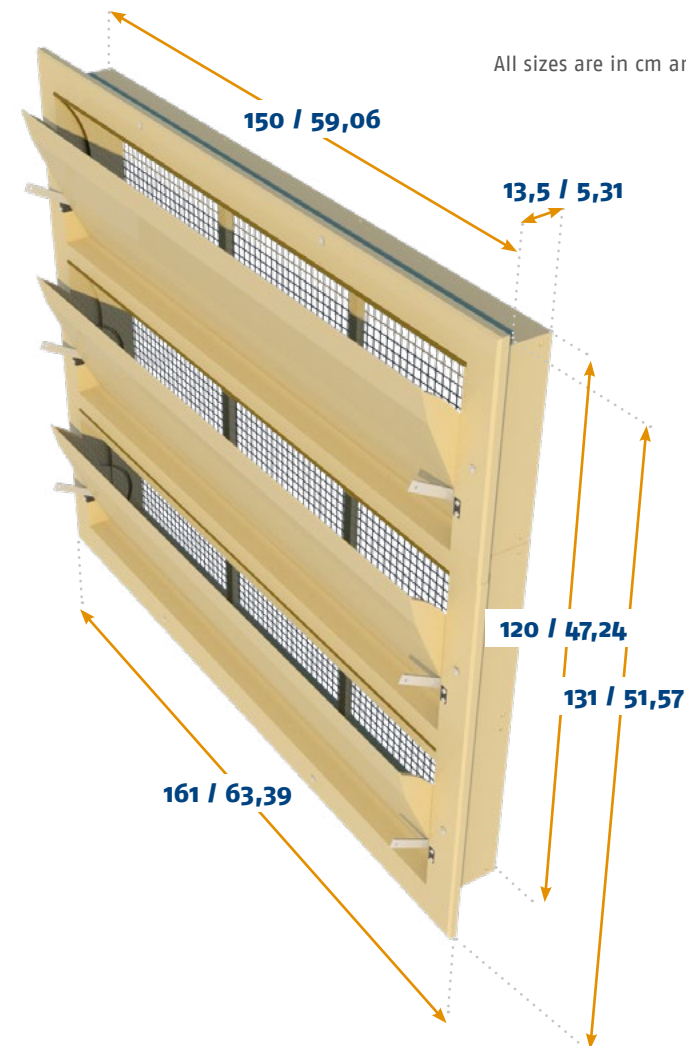
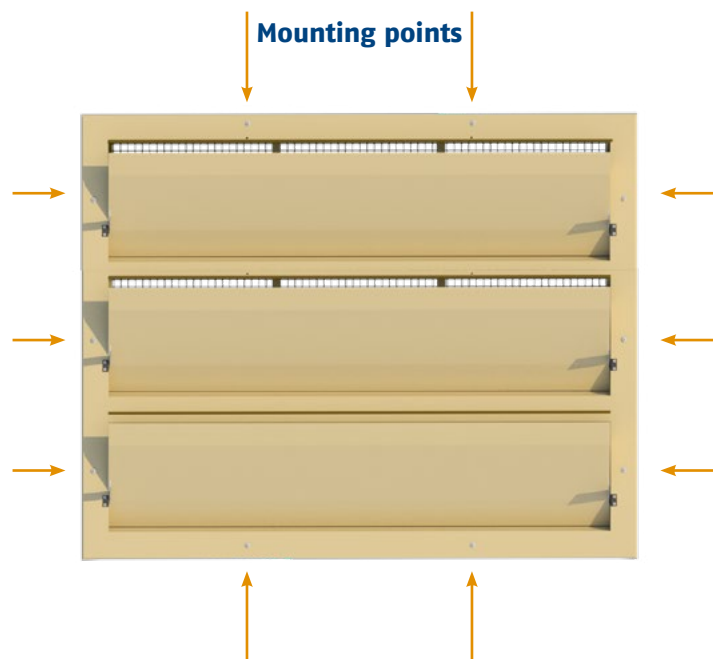

All sizes are in cm and inches

MOUNTING	
Mounting type	Wall
Mounting hole size	152 cm / 59,84 inch x 122 cm / 48,03 inch

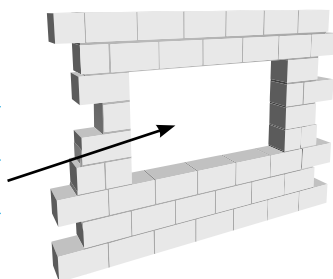

AIR FLOW

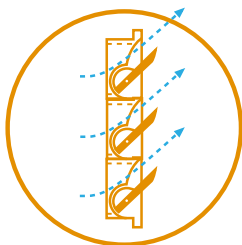

Middle hinged inlet

This middle hinged inlet is made to allow air to also flow underneath the inner flap after opening further than 35%. This helps to guide air downwards to the animals and provide a cooling effect during maximum ventilation.

Straight inner flap

This inlet is equipped with a straight inner flap. Straight flaps guide air in a straight upwards or horizontal direction, never downwards. This is ideal for houses where air should not be directed directly towards or over the animals during maximum ventilation.

Working with end-weights or springs

We offer two products which can be used to keep tension on the main cable. A PVC cylinder which can be filled with concrete or sand to act as end-weight, or a spring that holds tension on the cable.

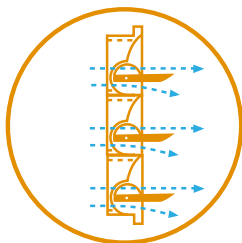

Balanced set-up

When placing the motor winch or actuator we normally suggest to divide the inlets in two groups. It is preferable to place the winch or actuator in the middle to equally divide the forces on the main cable.

(see ventilation concepts page for an example)

Use of closing catches

The closing catch on the inlet can be used to permanently close inlets for example during pre-heating. The closing catches can also be used to close certain inlets while continuing to use others. In that case the used inlets can be opened a bit further. In colder climates this can help to offer better resistance to freezing effects.

[INFO](#)
[DATASHEET](#)
[ASSEMBLY](#)
[MOUNTING](#)
[WORKING](#)
[MAINTENANCE](#)

6000-VFR-3-C

This tunnel unit is built up out of three single 6000-VFR inlets. This version is equipped with a straight inner valve that guides the air upwards during minimum ventilation. After opening further than 35% the air will also flow underneath the inner valve. This unit is controlled by two central arms per valve, which in turn, are connected with the other inner valves.



INFO

DATASHEET

ASSEMBLY

MOUNTING

WORKING

MAINTENANCE





6000-VFR-3-C DATASHEET



CAPACITY

Model	m ³ /h @ 10 Pa	m ³ /h @ 25 Pa	m ³ /h @ 40 Pa
6000-VFR-3-C	17400	26250	34800
	cfm @ 0.05 inH ₂ O	cfm @ 0.1 inH ₂ O	cfm @ 0.15 inH ₂ O
	11450	17239	19779

INFORMATION

Run	37 cm / 14.6 inch
Force	10.5kg / 103 Newton
Number / pallet (1.65 x 0.95 x 2.40 m)	5
Weight / per inlet	31,9 kg / 70.3 lbs
Volume / per box	1
Arm position	+

OPTIONAL ACCESSORIES

TPI-107 (*3)	Wire mesh synthetic
TPI-209c	Connection set
TPI-307 (*6)	Closing catch + spring
TPI-519 (*2)	Main cable support

AIR FLOW

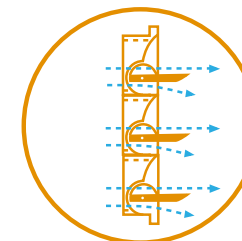
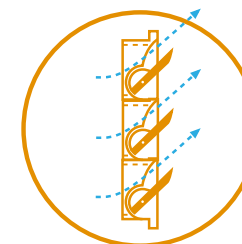

INFO

DATASHEET

ASSEMBLY

MOUNTING

WORKING

MAINTENANCE



6000-VFR-3-C ASSEMBLY

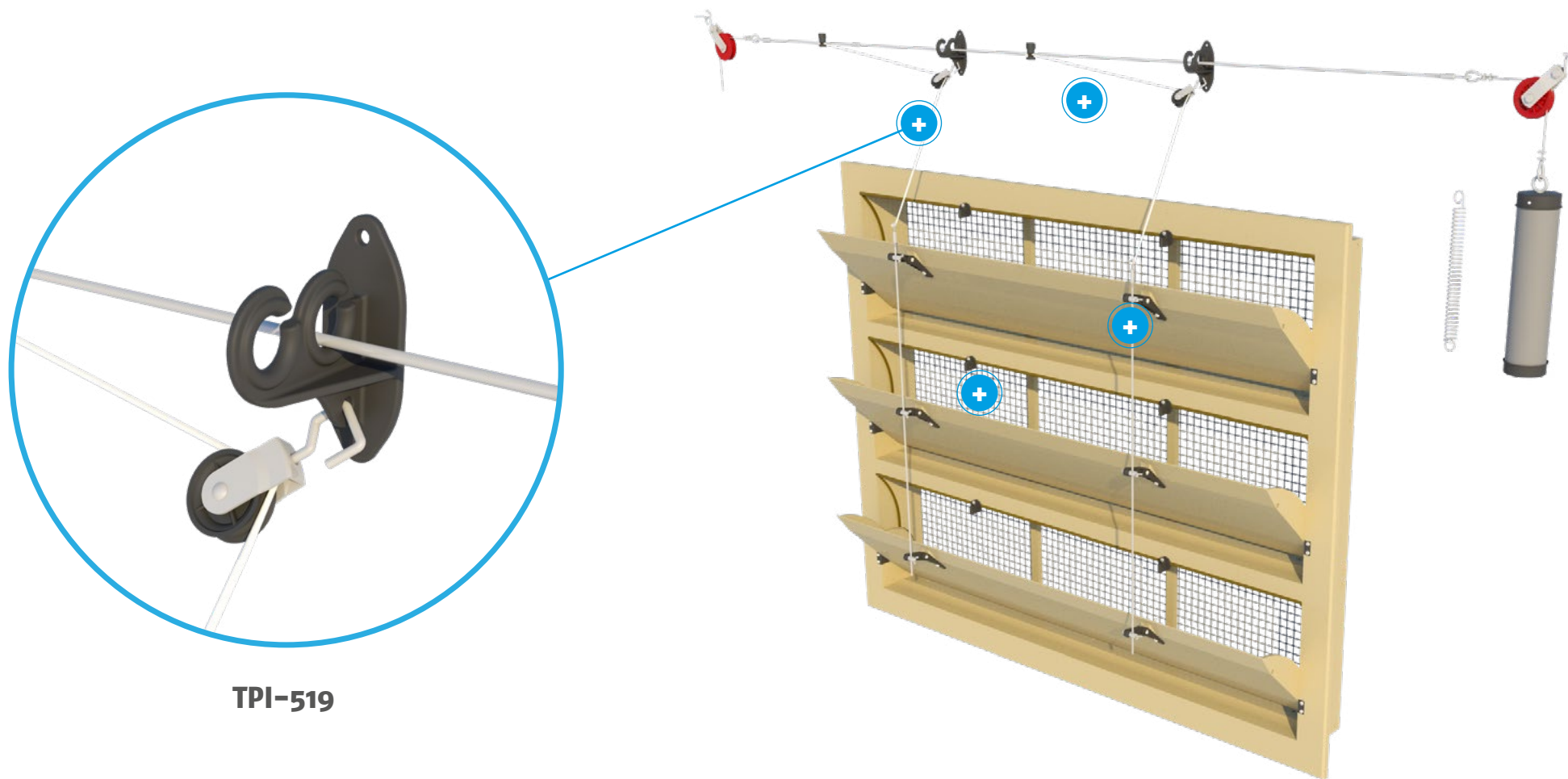

TPI-519

INFO

DATASHEET

ASSEMBLY

MOUNTING

WORKING

MAINTENANCE





TPI-209A

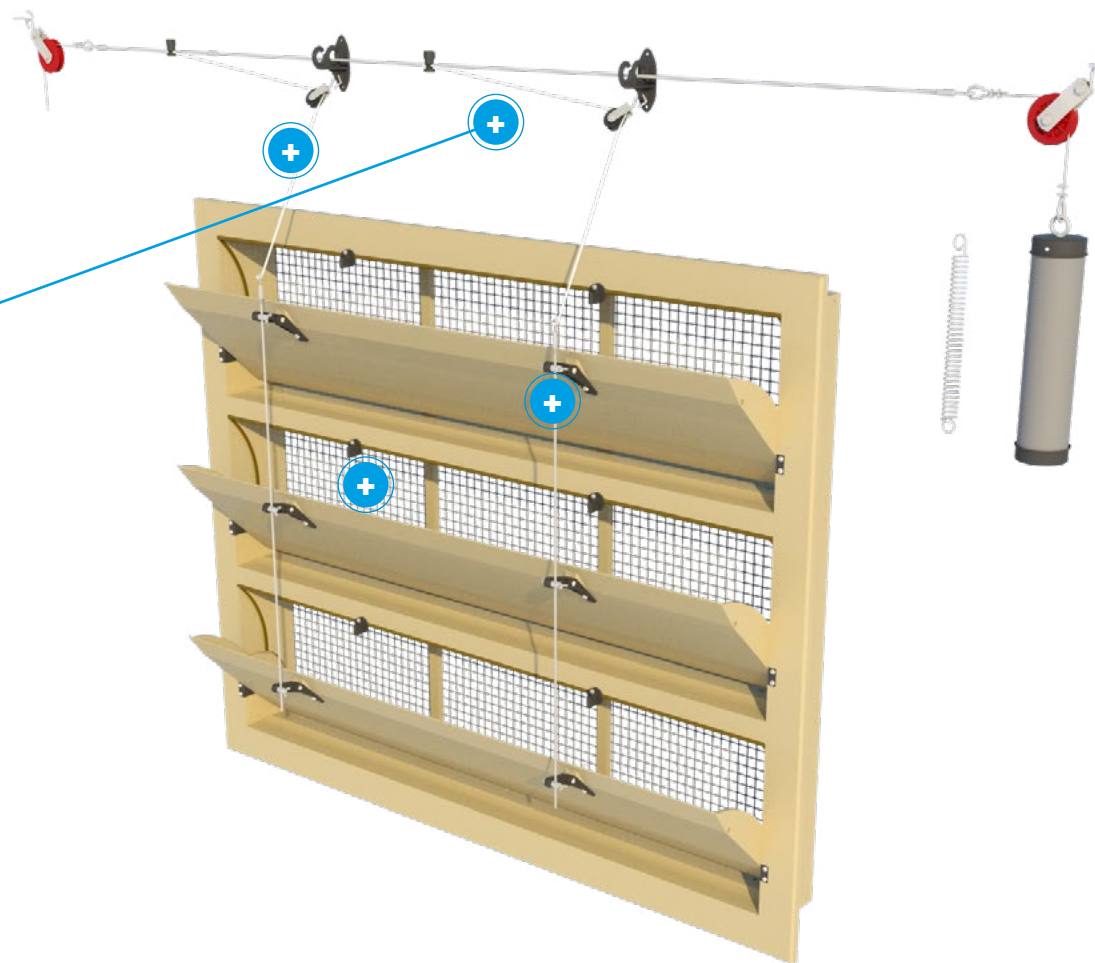

INFO

DATASHEET

ASSEMBLY

MOUNTING

WORKING

MAINTENANCE



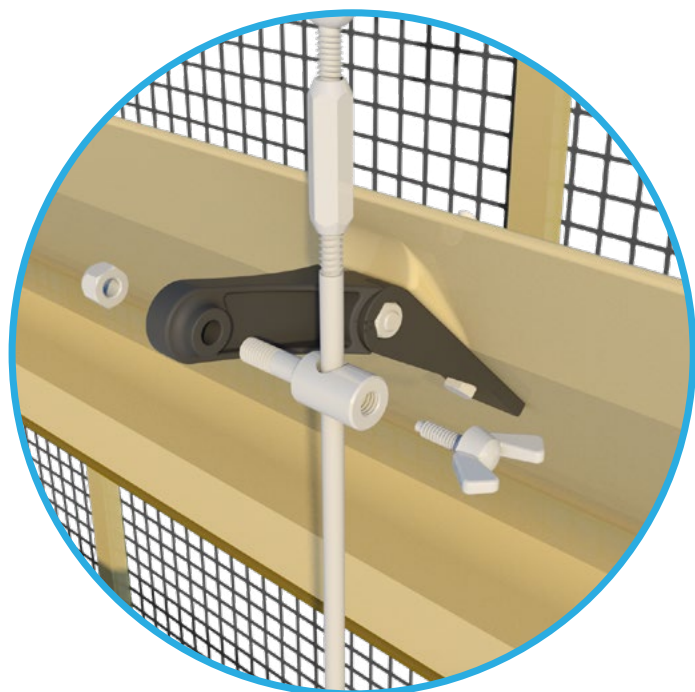

TPI-209A

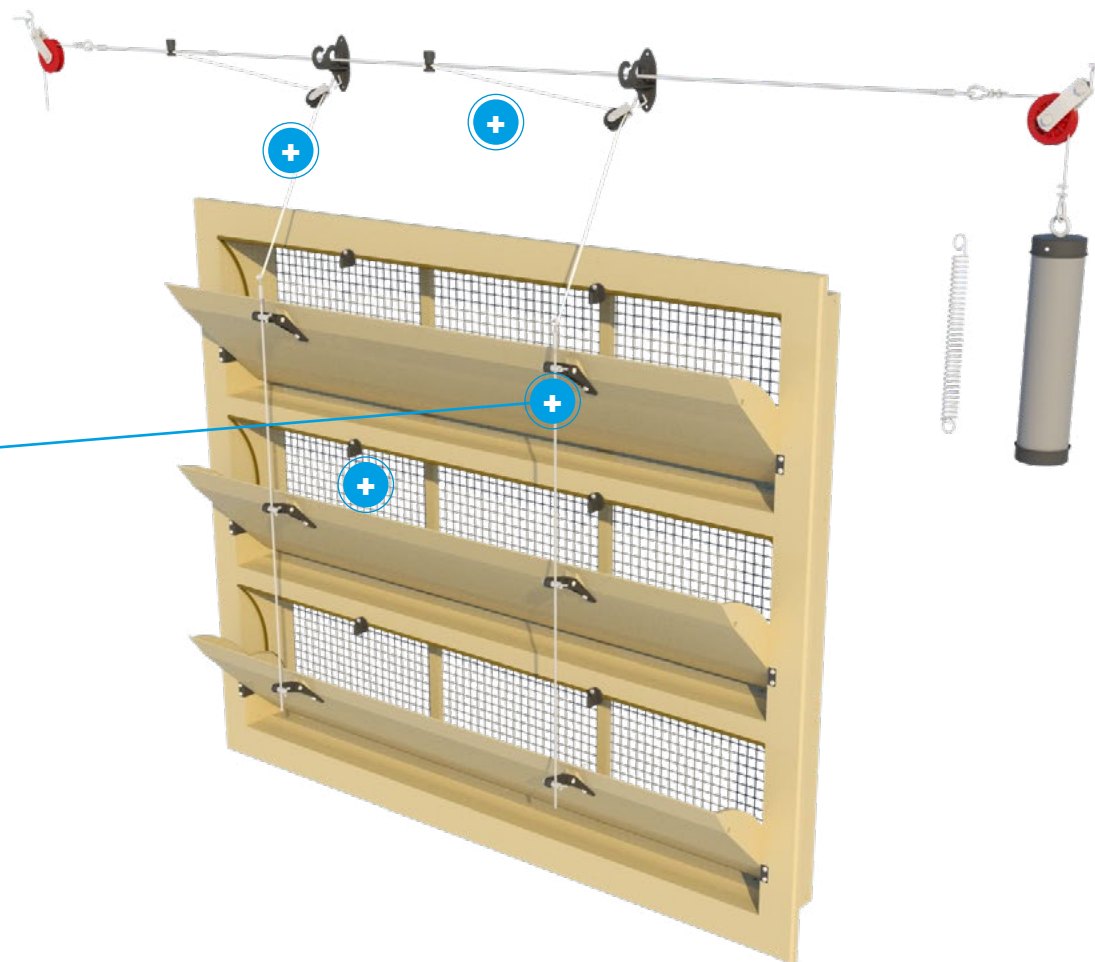

INFO

DATASHEET

ASSEMBLY

MOUNTING

WORKING

MAINTENANCE



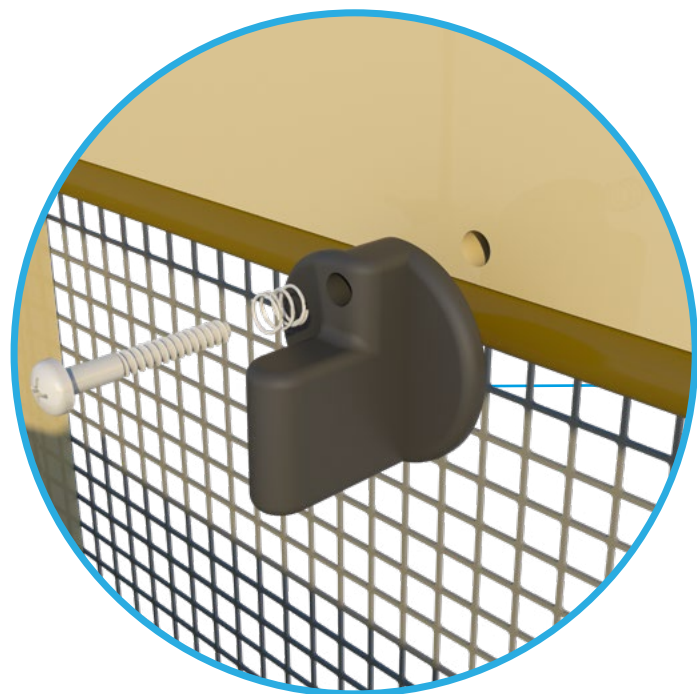

TPI-307

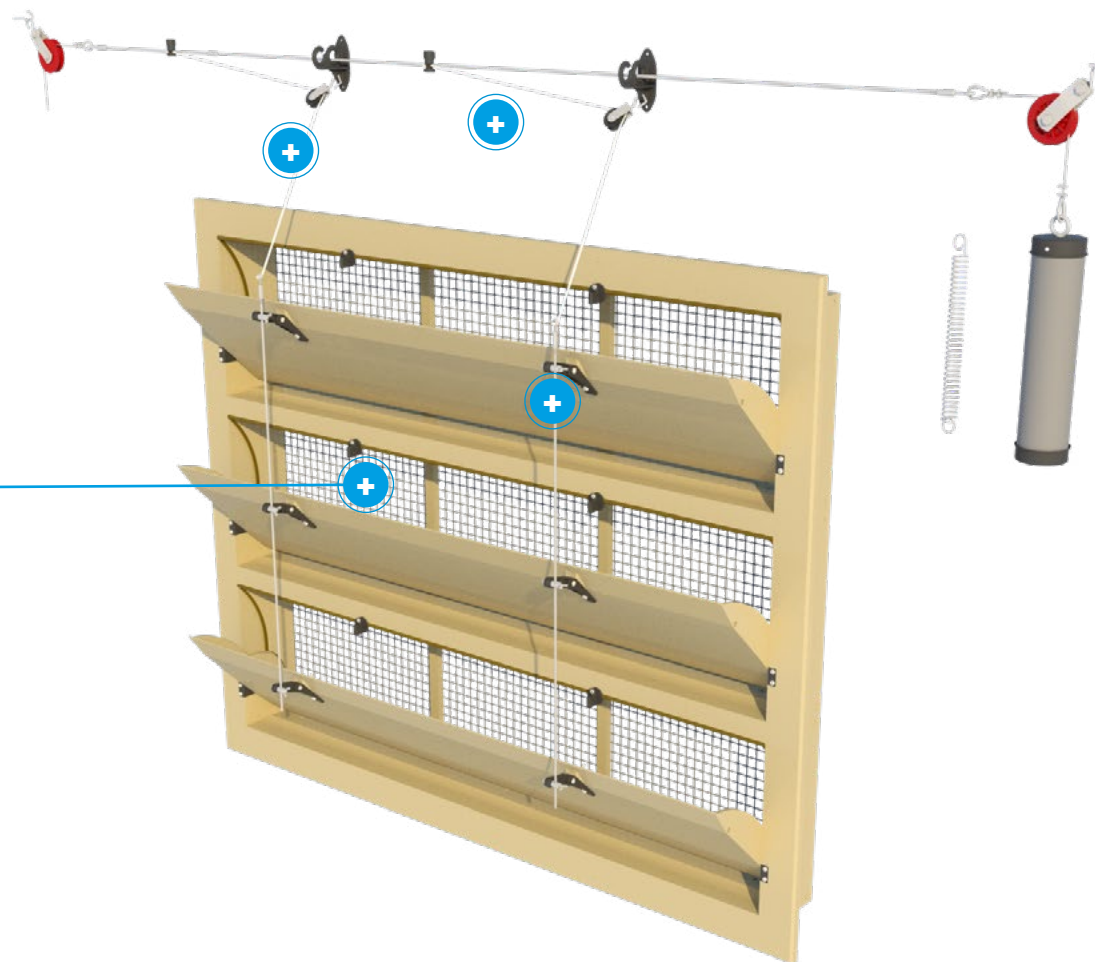

INFO

DATASHEET

ASSEMBLY

MOUNTING

WORKING

MAINTENANCE



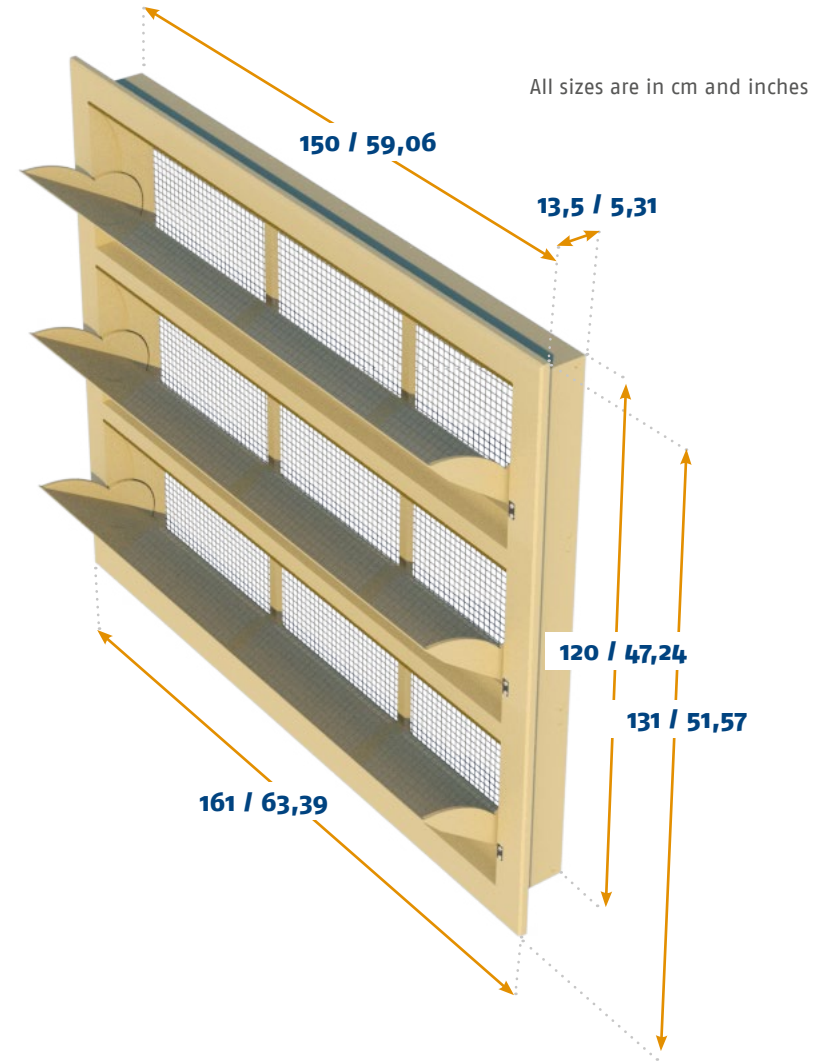
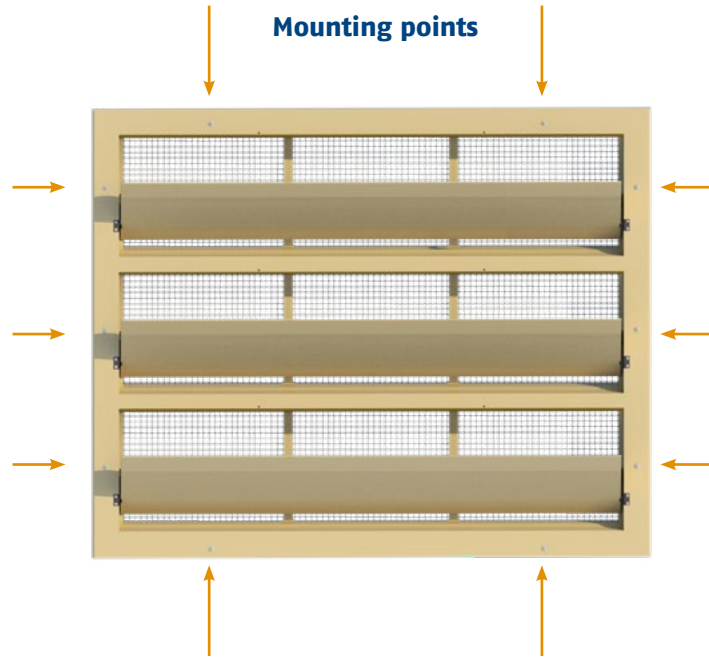

MOUNTING	
Mounting type	Wall
Mounting hole size	152 cm / 59,84 inch x 122 cm / 48,03 inch

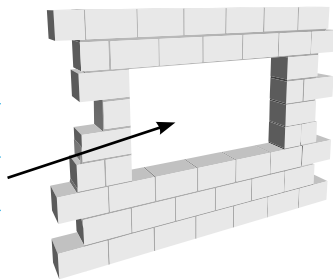

AIR FLOW

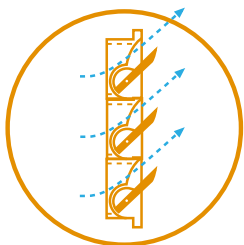

Middle hinged inlet

This middle hinged inlet is made to allow air to also flow underneath the inner flap after opening further then 35%. This helps to guide air downwards to the animals and provide a cooling effect during maximum ventilation.

Straight inner flap

This inlet is equipped with a straight inner flap. Straight flaps guide air in a straight upwards or horizontal direction, never downwards. This is ideal for houses where air should not be directed directly towards or over the animals during maximum ventilation.

Working with end-weights or springs

We offer two products which can be used to keep tension on the main cable. A PVC cylinder which can be filled with concrete or sand to act as end-weight, or a spring that holds tension on the cable.

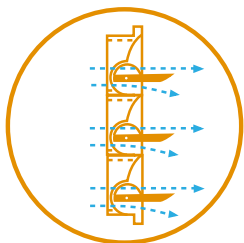

Balanced set-up

When placing the motor winch or actuator we normally suggest to divide the inlets in two groups. It is preferable to place the winch or actuator in the middle to equally divide the forces on the main cable.

(see ventilation concepts page for an example)

Use of closing catches

The closing catch on the inlet can be used to permanently close inlets for example during pre-heating. The closing catches can also be used to close certain inlets while continuing to use others. In that case the used inlets can be opened a bit further. In colder climates this can help to offer better resistance to freezing effects.



INFO

DATASHEET

ASSEMBLY

MOUNTING

WORKING

MAINTENANCE



6000-VFR-4

This tunnel unit is built up out of four single 6000-VFR inlets. This version is equipped with a straight inner valve that guides the air upwards during minimum ventilation. After opening further than 35% the air will also flow underneath the inner valve. This unit is controlled by side arms that connect the inner valves.



INFO

DATASHEET

ASSEMBLY

MOUNTING

WORKING

MAINTENANCE





6000-VFR-4 DATASHEET



CAPACITY

Model	m ³ /h @ 10 Pa	m ³ /h @ 25 Pa	m ³ /h @ 40 Pa
6000-VFR-4	23200	35000	46400
	cfm @ 0.05 inH ₂ O	cfm @ 0.1 inH ₂ O	cfm @ 0.15 inH ₂ O
	15267	22986	26372

INFORMATION

Run	17 cm / 6.7 inch
Force	52 kg / 510 Newton
Number / pallet (1.65 x 0.95 x 2.40 m)	5
Weight / per inlet	42,5 kg / 93.7 lbs
Volume / per box	1

OPTIONAL ACCESSORIES

TPI-107 (*4)	Wire mesh synthetic
TPI-210a	Connection set
TPI-307 (*8)	Closing catch + spring
TPI-519 (*2)	Main cable support

AIR FLOW

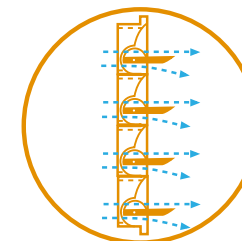
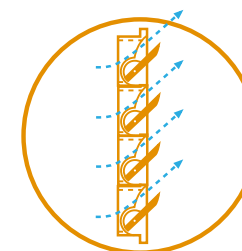

INFO

DATASHEET

ASSEMBLY

MOUNTING

WORKING

MAINTENANCE



6000-VFR-4 ASSEMBLY

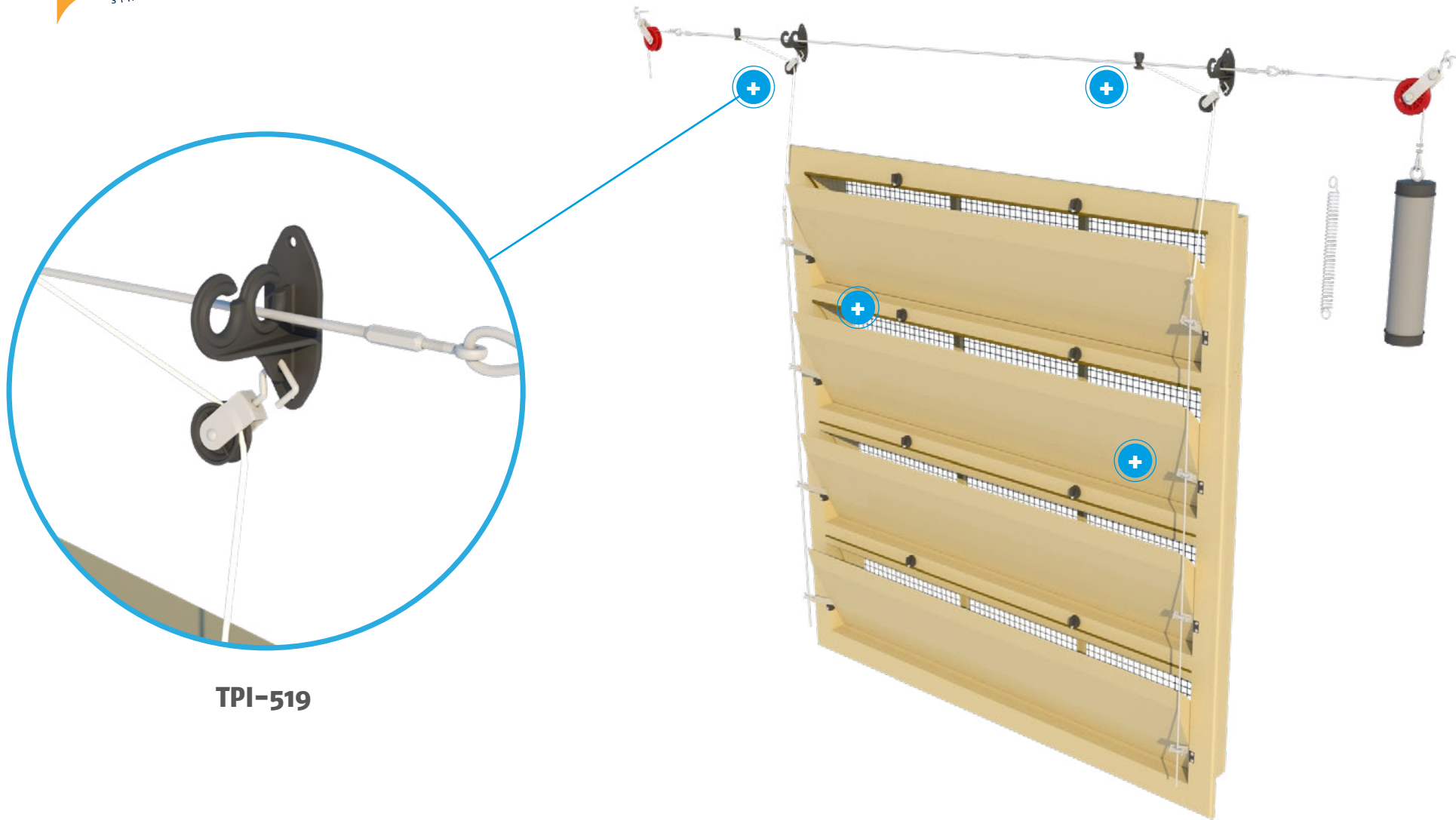

TPI-519

INFO

DATASHEET

ASSEMBLY

MOUNTING

WORKING

MAINTENANCE





6000-VFR-4 ASSEMBLY



TPI-210A

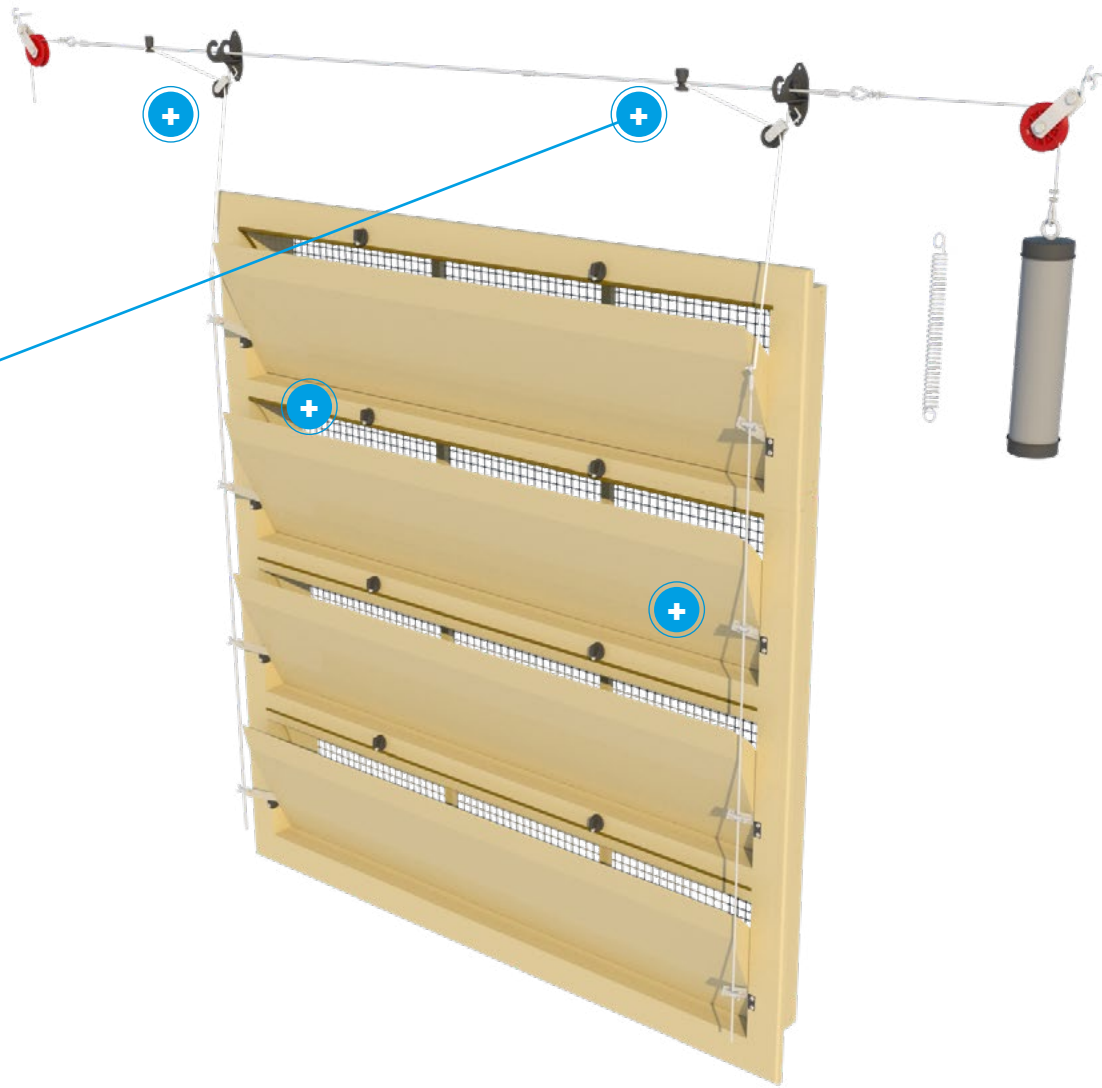

[INFO](#)

[DATASHEET](#)

[ASSEMBLY](#)

[MOUNTING](#)

[WORKING](#)

[MAINTENANCE](#)



6000-VFR-4 ASSEMBLY

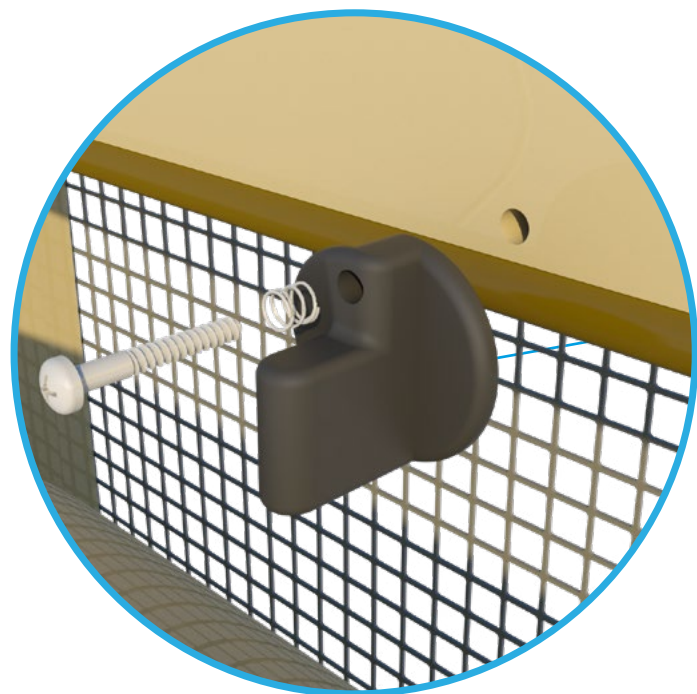

TPI-307

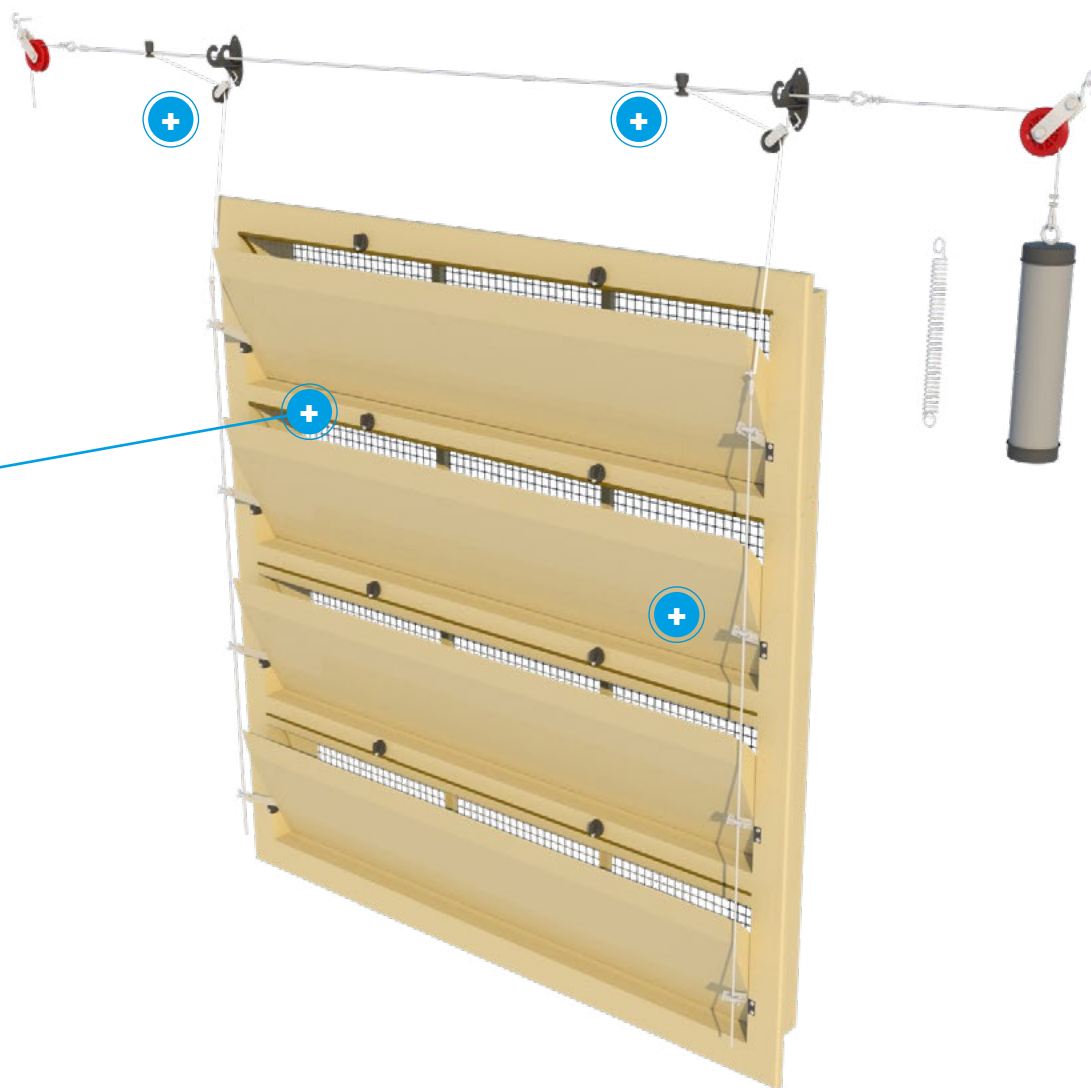

INFO

DATASHEET

ASSEMBLY

MOUNTING

WORKING

MAINTENANCE





6000-VFR-4 ASSEMBLY

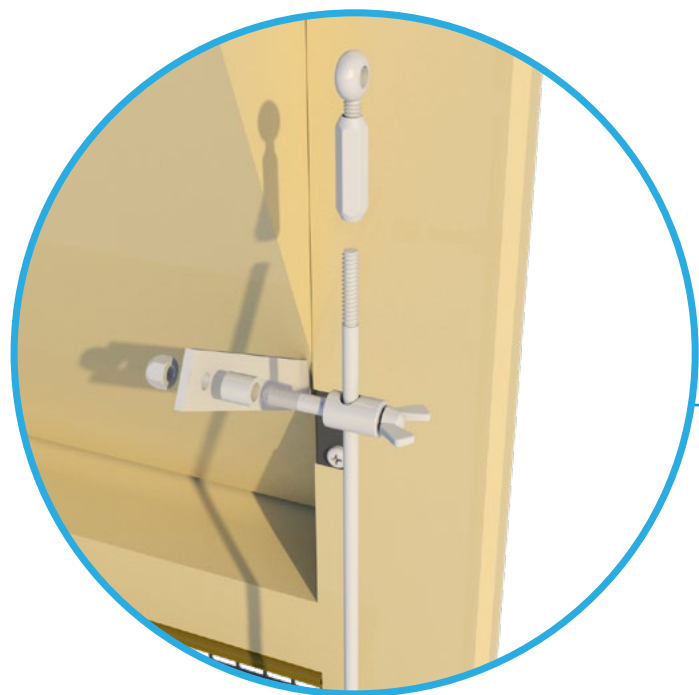

TPI-210A

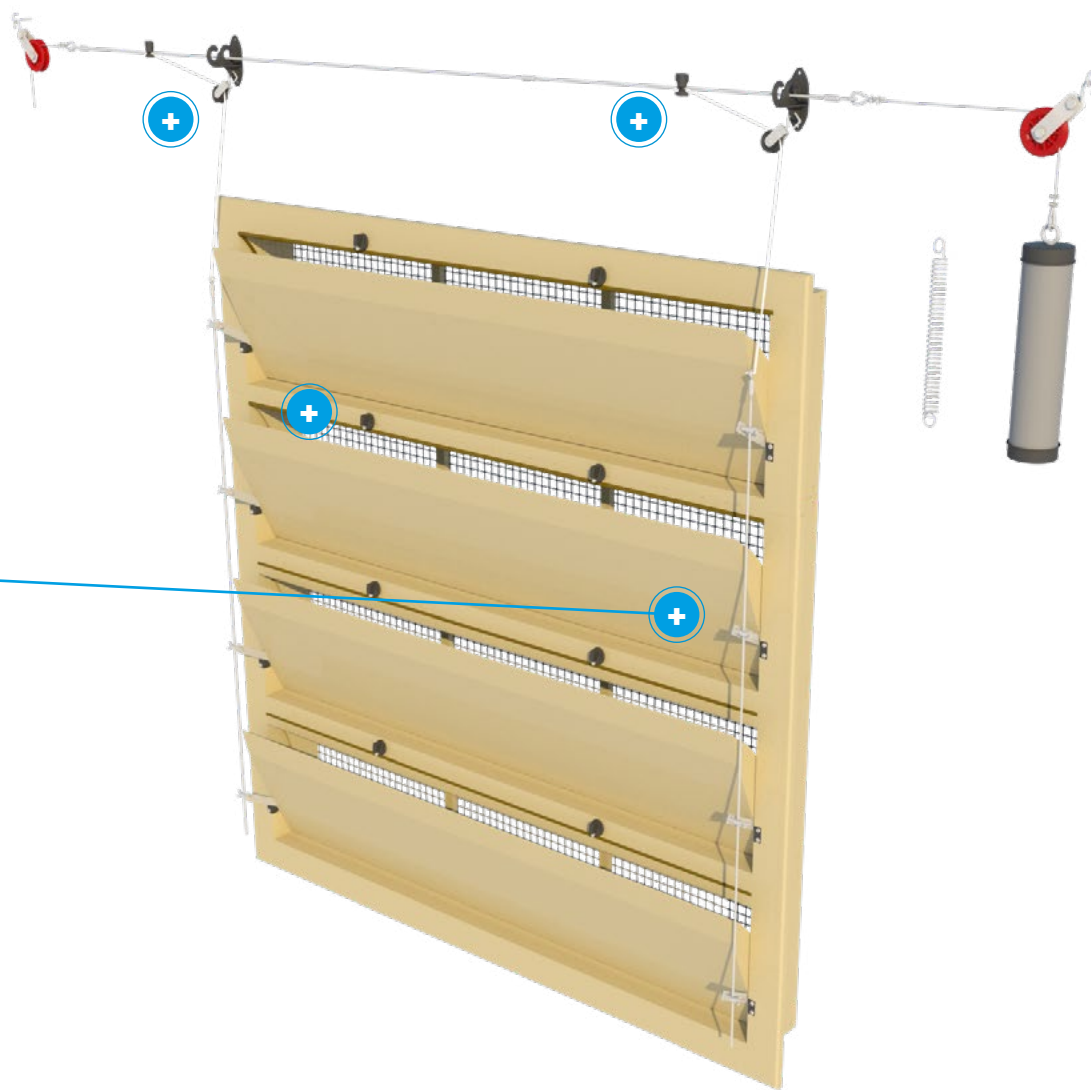

INFO

DATASHEET

ASSEMBLY

MOUNTING

WORKING

MAINTENANCE



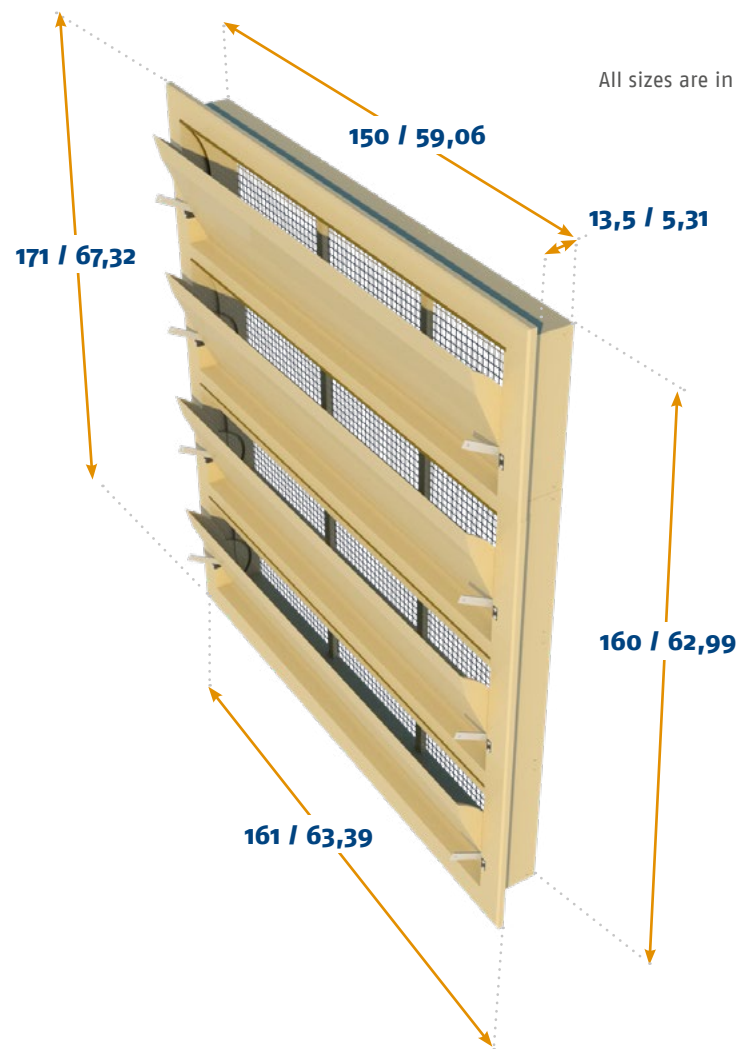
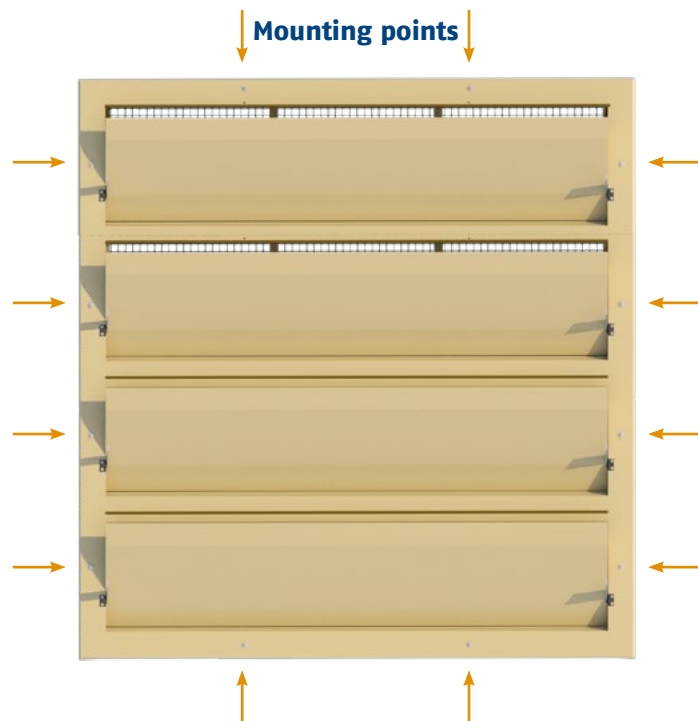

All sizes are in cm and inches

MOUNTING

Mounting type	Wall
Mounting hole size	152 cm / 59,84 inch x 162 cm / 63,78 inch

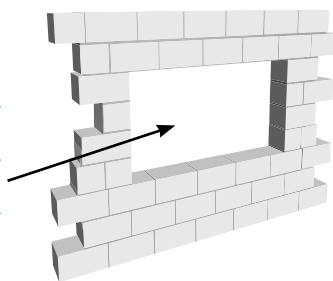

INFO

DATASHEET

ASSEMBLY

MOUNTING

WORKING

MAINTENANCE



AIR FLOW

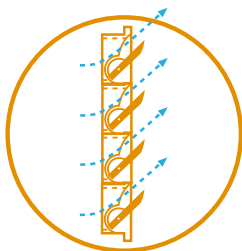

Middle hinged inlet

This middle hinged inlet is made to allow air to also flow underneath the inner flap after opening further then 35%. This helps to guide air downwards to the animals and provide a cooling effect during maximum ventilation.

Straight inner flap

This inlet is equipped with a straight inner flap. Straight flaps guide air in a straight upwards or horizontal direction, never downwards. This is ideal for houses where air should not be directed directly towards or over the animals during maximum ventilation.

Working with end-weights or springs

We offer two products which can be used to keep tension on the main cable. A PVC cylinder which can be filled with concrete or sand to act as end-weight, or a spring that holds tension on the cable.

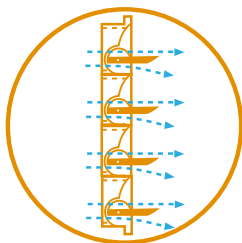

Balanced set-up

When placing the motor winch or actuator we normally suggest to divide the inlets in two groups. It is preferable to place the winch or actuator in the middle to equally divide the forces on the main cable.

(see ventilation concepts page for an example)

Use of closing catches

The closing catch on the inlet can be used to permanently close inlets for example during pre-heating. The closing catches can also be used to close certain inlets while continuing to use others. In that case the used inlets can be opened a bit further. In colder climates this can help to offer better resistance to freezing effects.



INFO

DATASHEET

ASSEMBLY

MOUNTING

WORKING

MAINTENANCE



6000-VFR-4-C

This tunnel unit is built up out of four single 6000-VFR inlets. This version is equipped with a straight inner valve that guides the air upwards during minimum ventilation. After opening further than 35% the air will also flow underneath the inner valve. This unit is controlled by two central arms per valve, which in turn, are connected with the other inner valves.

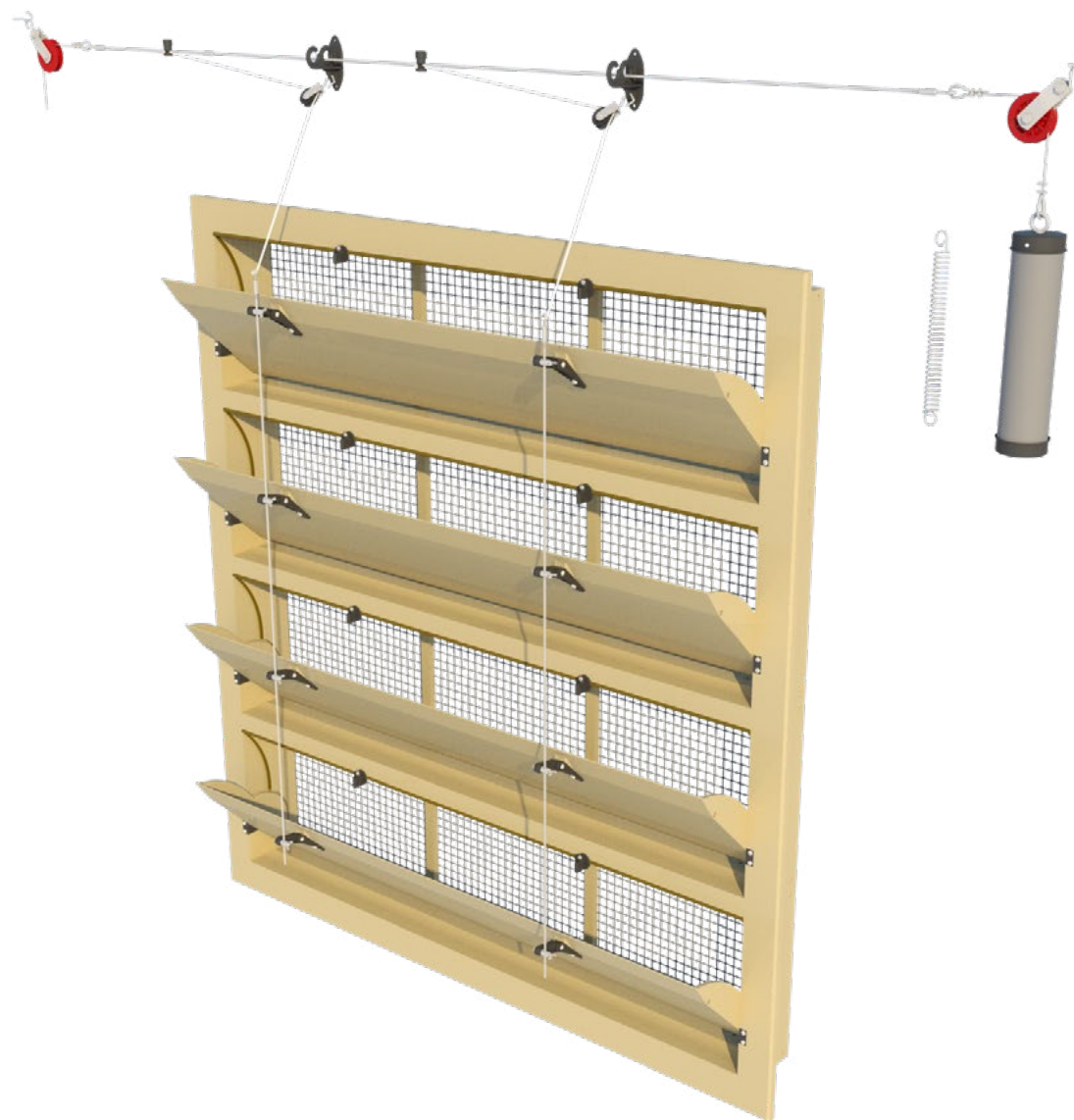

INFO

DATASHEET

ASSEMBLY

MOUNTING

WORKING

MAINTENANCE





6000-VFR-4-C DATASHEET



CAPACITY

Model	m ³ /h @ 10 Pa	m ³ /h @ 25 Pa	m ³ /h @ 40 Pa
6000-VFR-4-C	23200	35000	46400
	cfm @ 0.05 inH ₂ O	cfm @ 0.1 inH ₂ O	cfm @ 0.15 inH ₂ O
	15267	22986	26372

INFORMATION

Run	37 cm / 14.6 inch
Force	14 kg / 137.3 Newton
Number / pallet (1.65 x 0.95 x 2.40 m)	5
Weight / per inlet	42,5 kg / 93.7 lbs
Volume / per box	1
Arm position	3+

OPTIONAL ACCESSORIES

TPI-107 (*4)	Wire mesh synthetic
TPI-210c	Connection set
TPI-307 (*8)	Closing catch + spring
TPI-519 (*2)	Main cable support

AIR FLOW

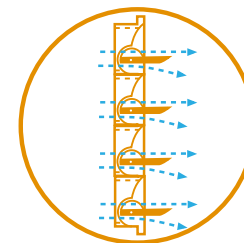
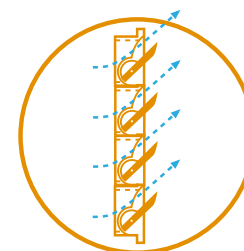

INFO

DATASHEET

ASSEMBLY

MOUNTING

WORKING

MAINTENANCE



6000-VFR-4-C ASSEMBLY

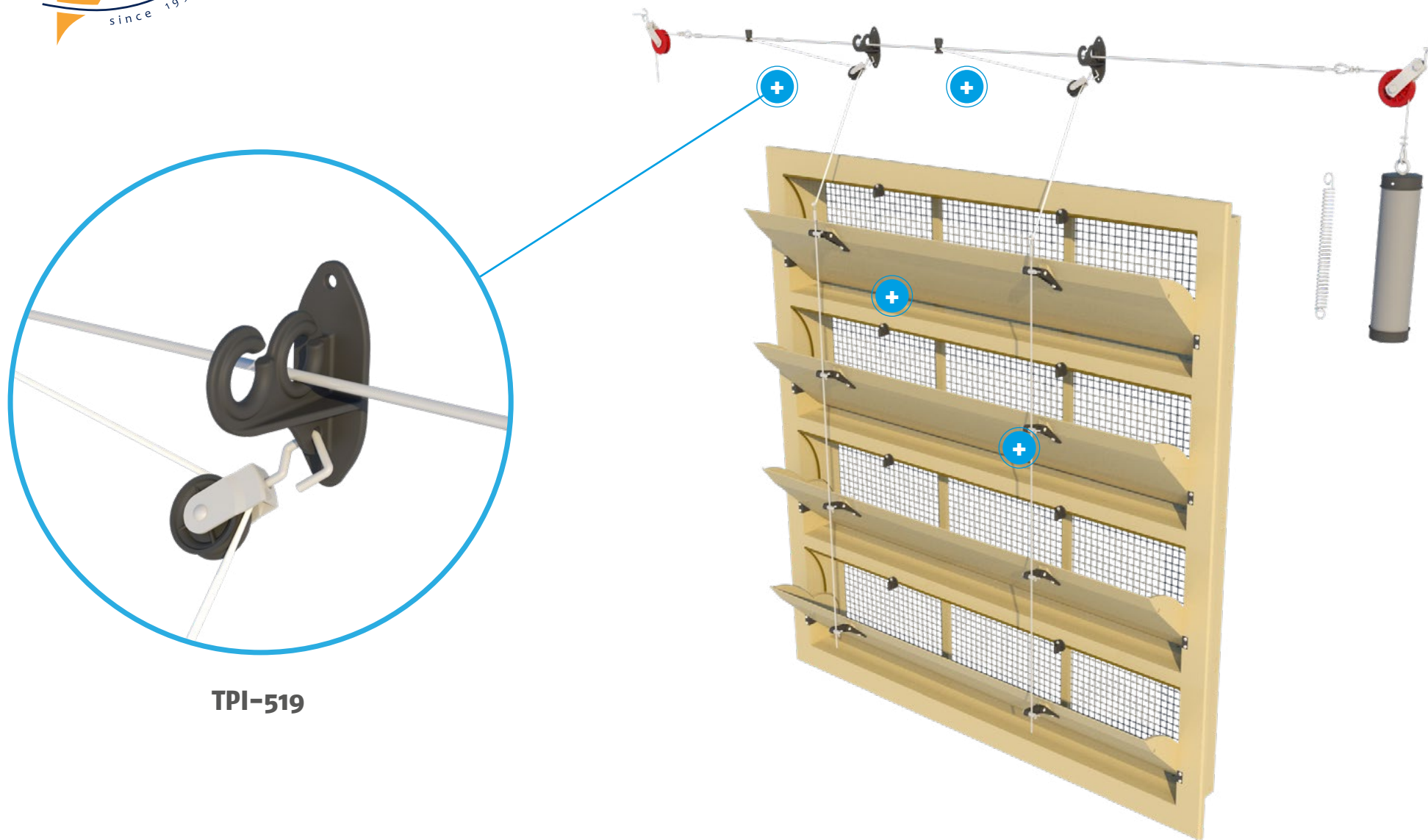

TPI-519

6000-VFR-4-C ASSEMBLY



TPI-210C

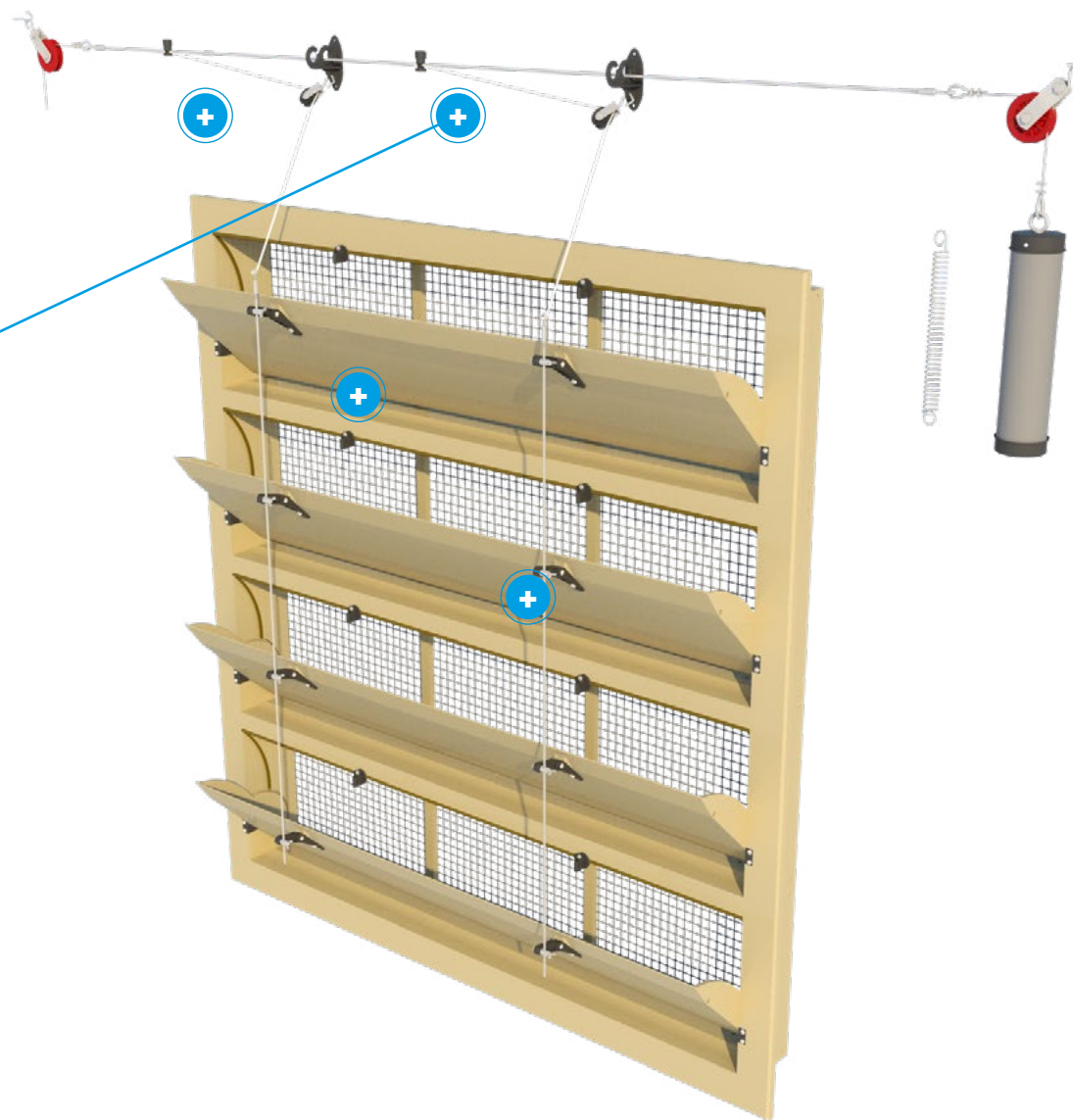

INFO

DATASHEET

ASSEMBLY

MOUNTING

WORKING

MAINTENANCE



6000-VFR-4-C ASSEMBLY

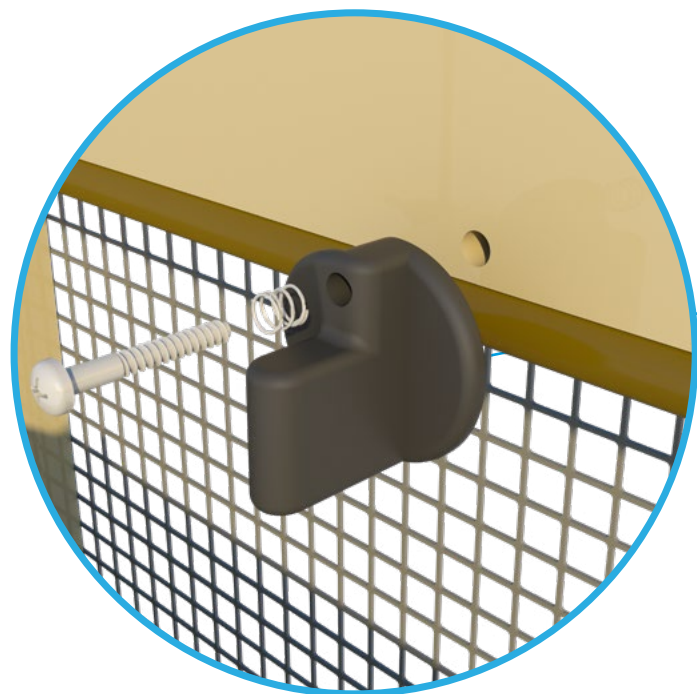

TPI-307

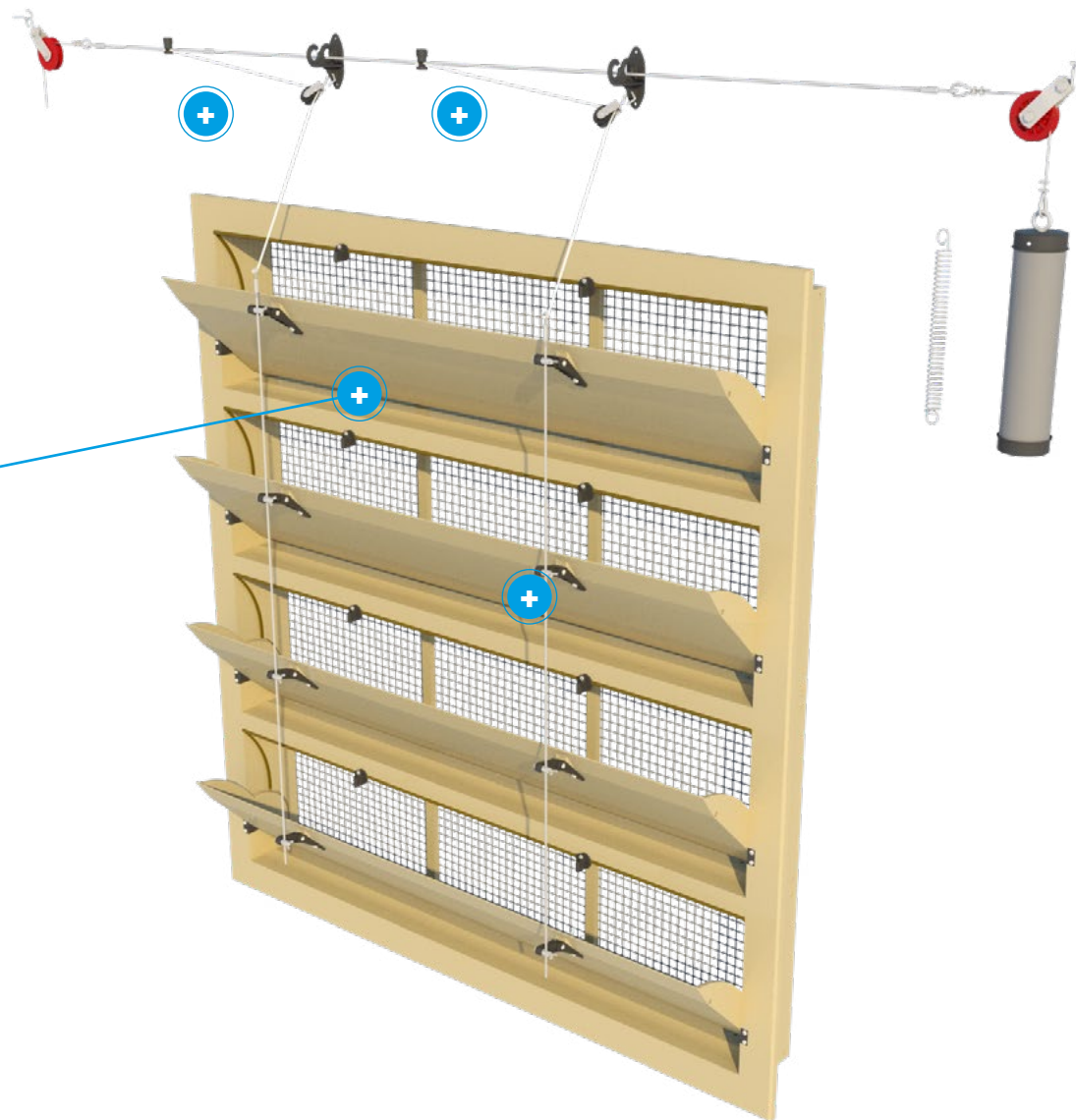

INFO

DATASHEET

ASSEMBLY

MOUNTING

WORKING

MAINTENANCE





6000-VFR-4-C ASSEMBLY

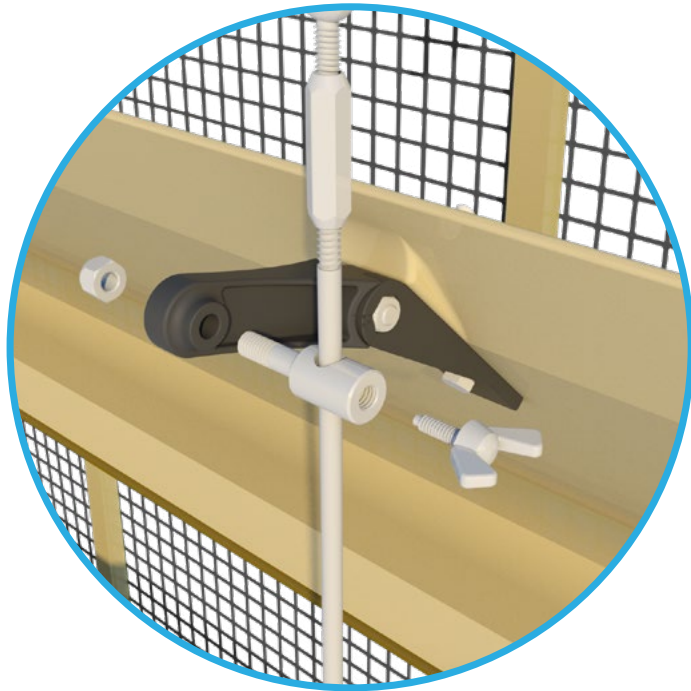

TPI-210C

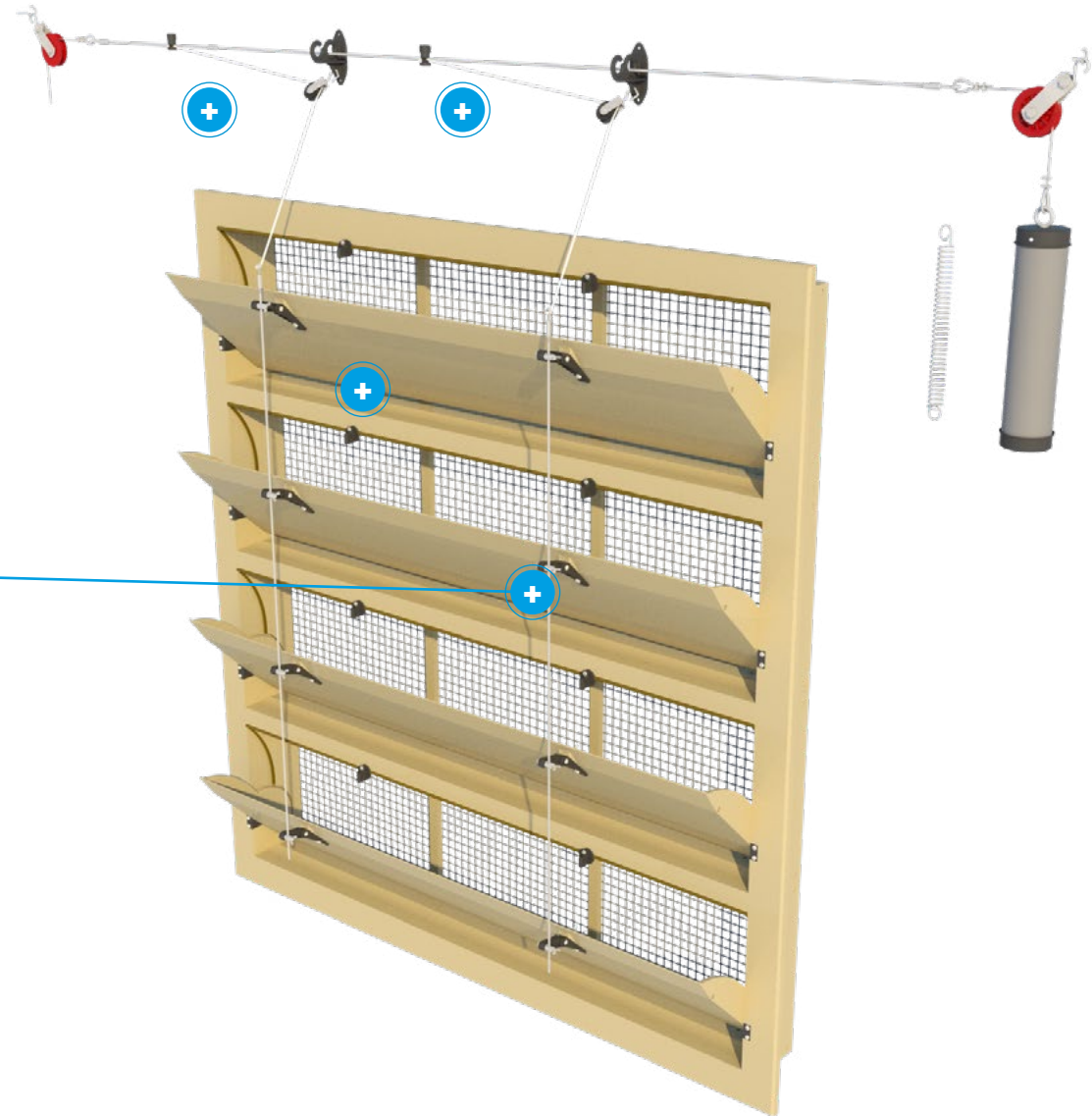

INFO

DATASHEET

ASSEMBLY

MOUNTING

WORKING

MAINTENANCE



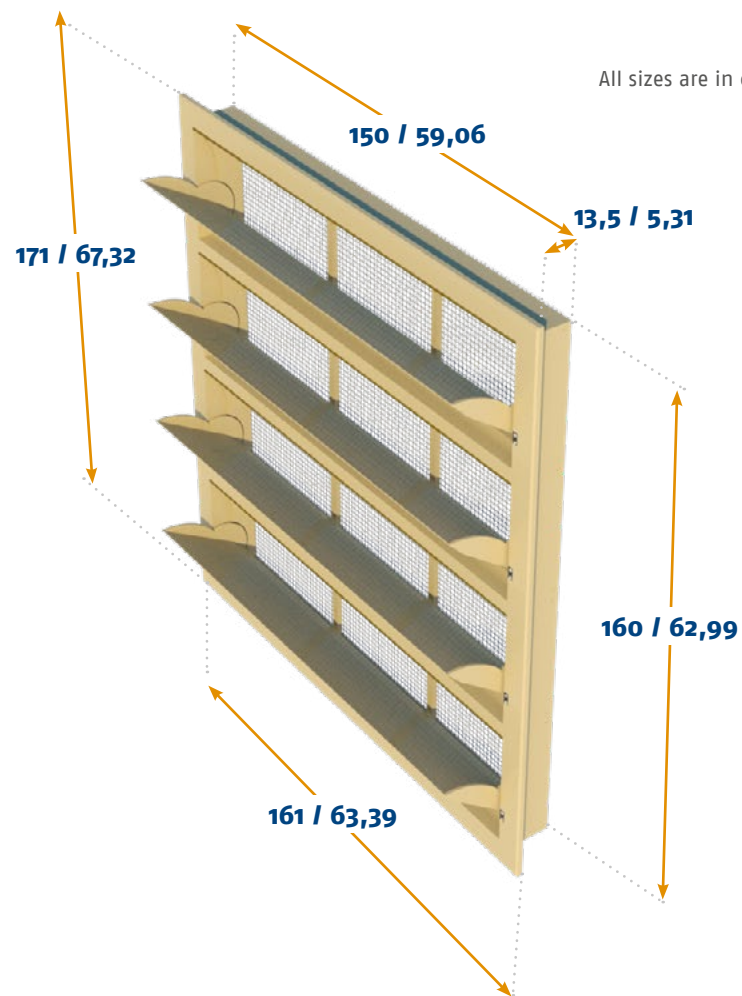
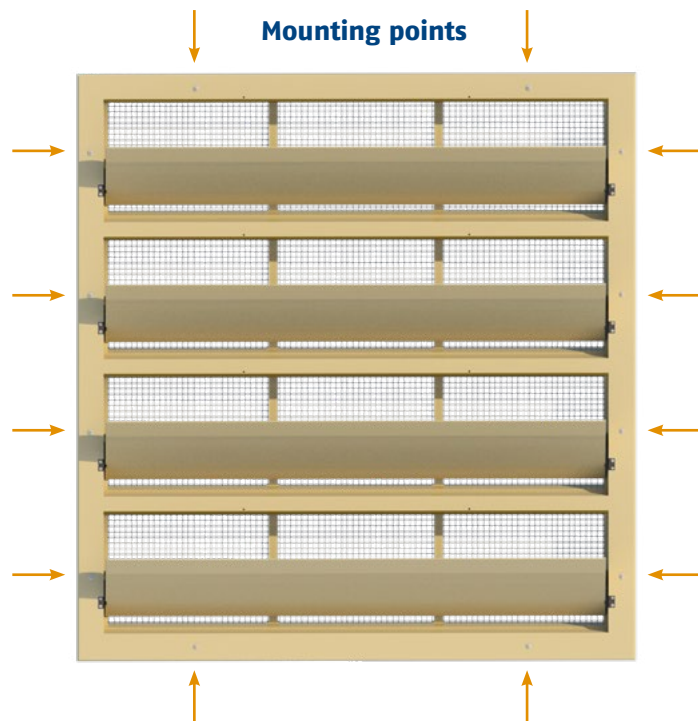

All sizes are in cm and inches

MOUNTING

Mounting type	Wall
Mounting hole size	152 cm / 59,84 inch x 162 cm / 63,78 inch

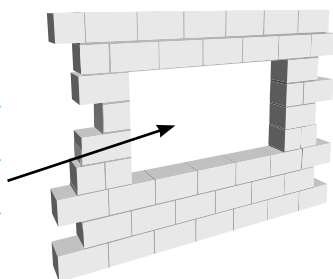

INFO

DATASHEET

ASSEMBLY

MOUNTING

WORKING

MAINTENANCE



AIR FLOW

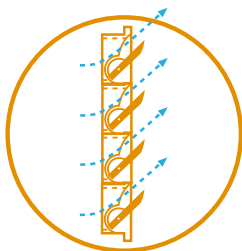

Middle hinged inlet

This middle hinged inlet is made to allow air to also flow underneath the inner flap after opening further then 35%. This helps to guide air downwards to the animals and provide a cooling effect during maximum ventilation.

Straight inner flap

This inlet is equipped with a straight inner flap. Straight flaps guide air in a straight upwards or horizontal direction, never downwards. This is ideal for houses where air should not be directed directly towards or over the animals during maximum ventilation.

Working with end-weights or springs

We offer two products which can be used to keep tension on the main cable. A PVC cylinder which can be filled with concrete or sand to act as end-weight, or a spring that holds tension on the cable.

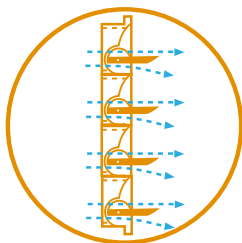

Balanced set-up

When placing the motor winch or actuator we normally suggest to divide the inlets in two groups. It is preferable to place the winch or actuator in the middle to equally divide the forces on the main cable.

(see ventilation concepts page for an example)

Use of closing catches

The closing catch on the inlet can be used to permanently close inlets for example during pre-heating. The closing catches can also be used to close certain inlets while continuing to use others. In that case the used inlets can be opened a bit further. In colder climates this can help to offer better resistance to freezing effects.



INFO

DATASHEET

ASSEMBLY

MOUNTING

WORKING

MAINTENANCE



84-P-C

This inlet is specially designed for installation in ceilings. The inlet is used to bring air from the attic into the house. Working with ceiling inlets, in turn, helps to pre-heat the temperature of incoming air. The inlet is controlled by means of a central plastic arm.



INFO

DATASHEET

ASSEMBLY

MOUNTING

WORKING

MAINTENANCE



CAPACITY

Model	m ³ /h @ 10 Pa	m ³ /h @ 20 Pa	m ³ /h @ 40 Pa
84-P-C	760	1070	1520
	cfm @ 0.05 inH ₂ O	cfm @ 0.1 inH ₂ O	cfm @ 0.15 inH ₂ O
	500	703	864

INFORMATION

Run	18 cm / 7.1 inch
Force	1 kg / 9.8 Newton
Number / pallet (1.20 x 0.80 x 2.40 m)	27
Weight / per inlet	2 kg / 4.4 lbs
Volume / per box	9
Arm position	3

OPTIONAL ACCESSORIES

TPI-204c	Connection set
TPI-740	Extension piece

AIR FLOW

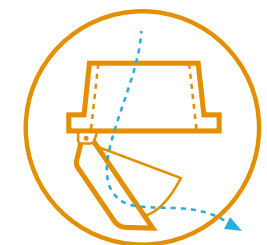
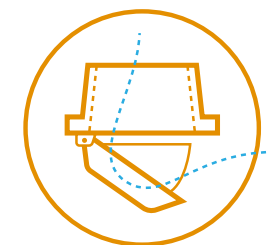

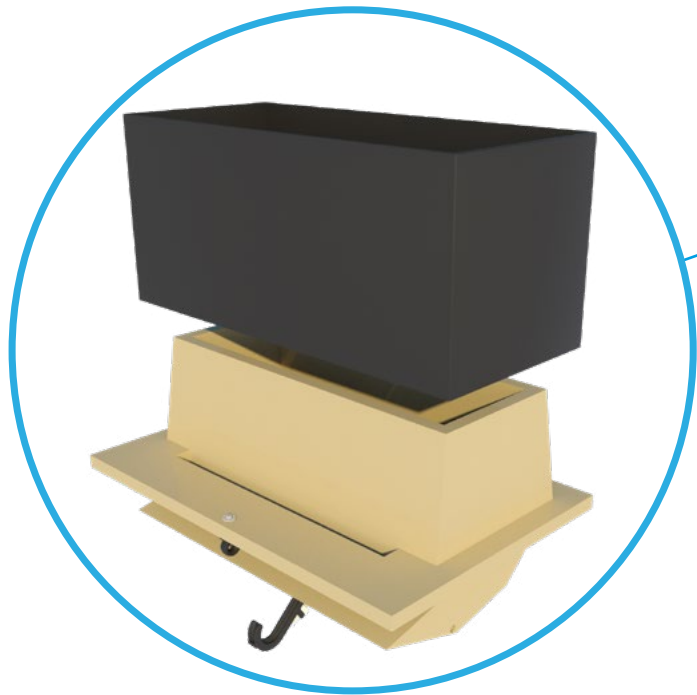

TPI-740

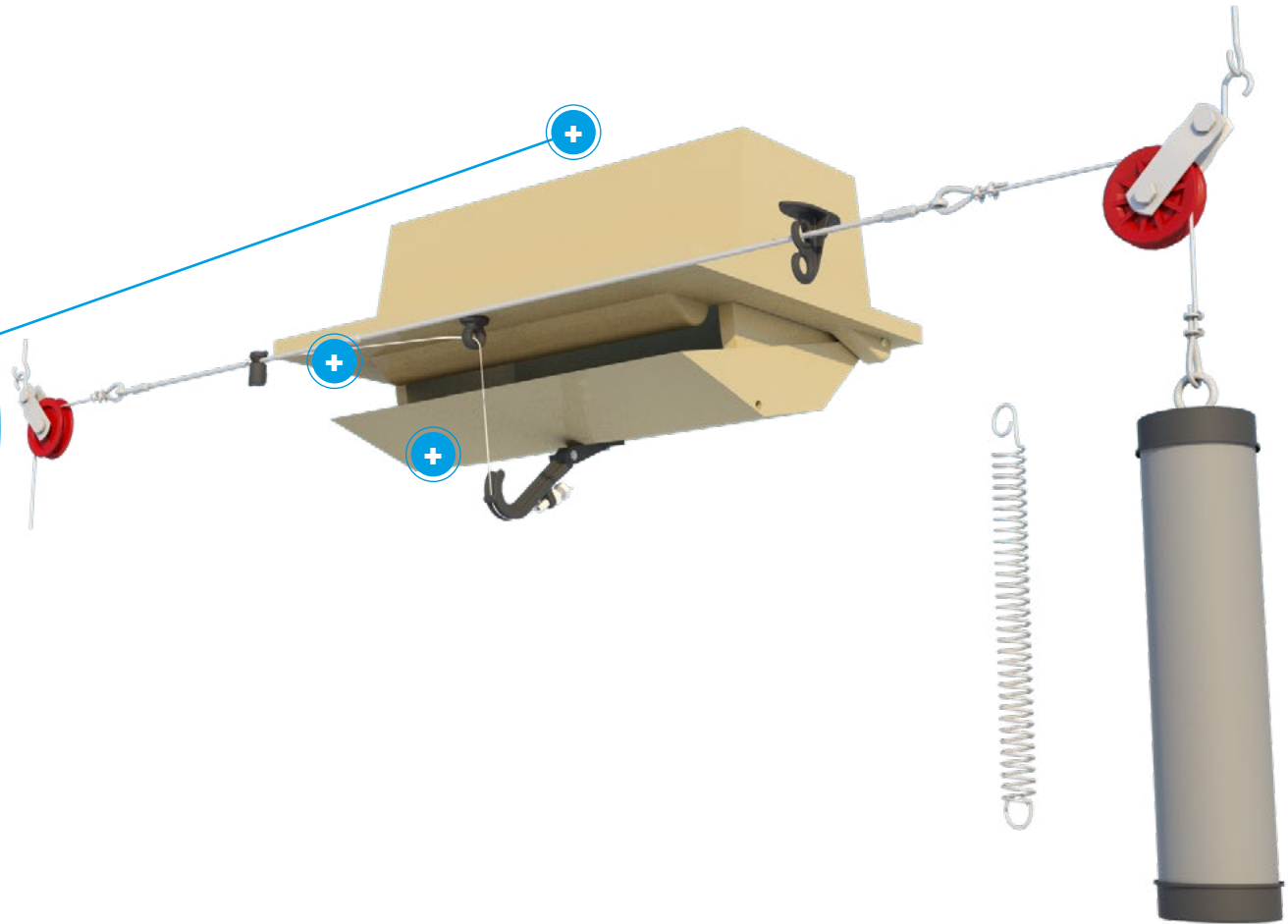



TPI-204C

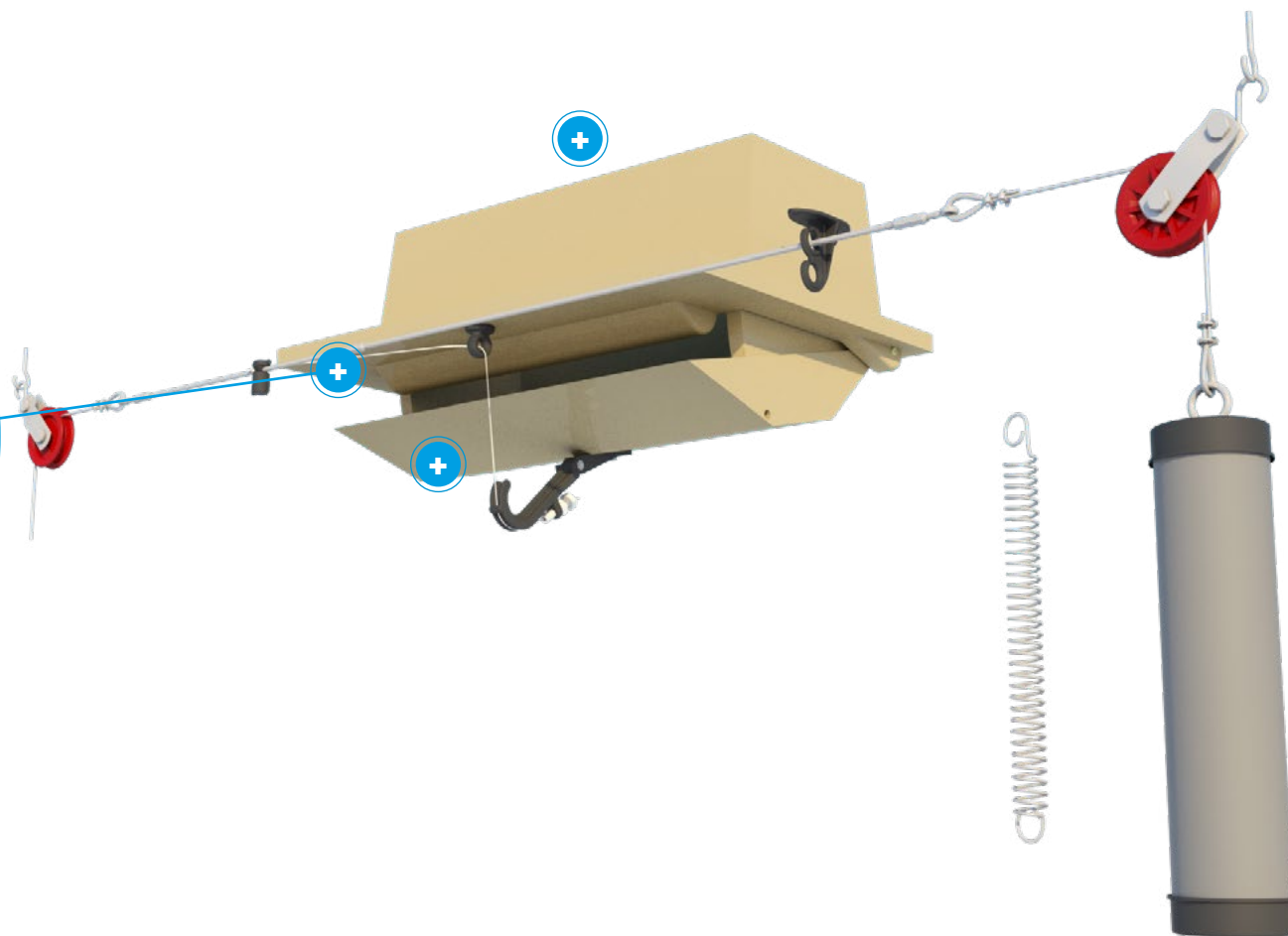

INFO

DATASHEET

ASSEMBLY

MOUNTING

WORKING

MAINTENANCE



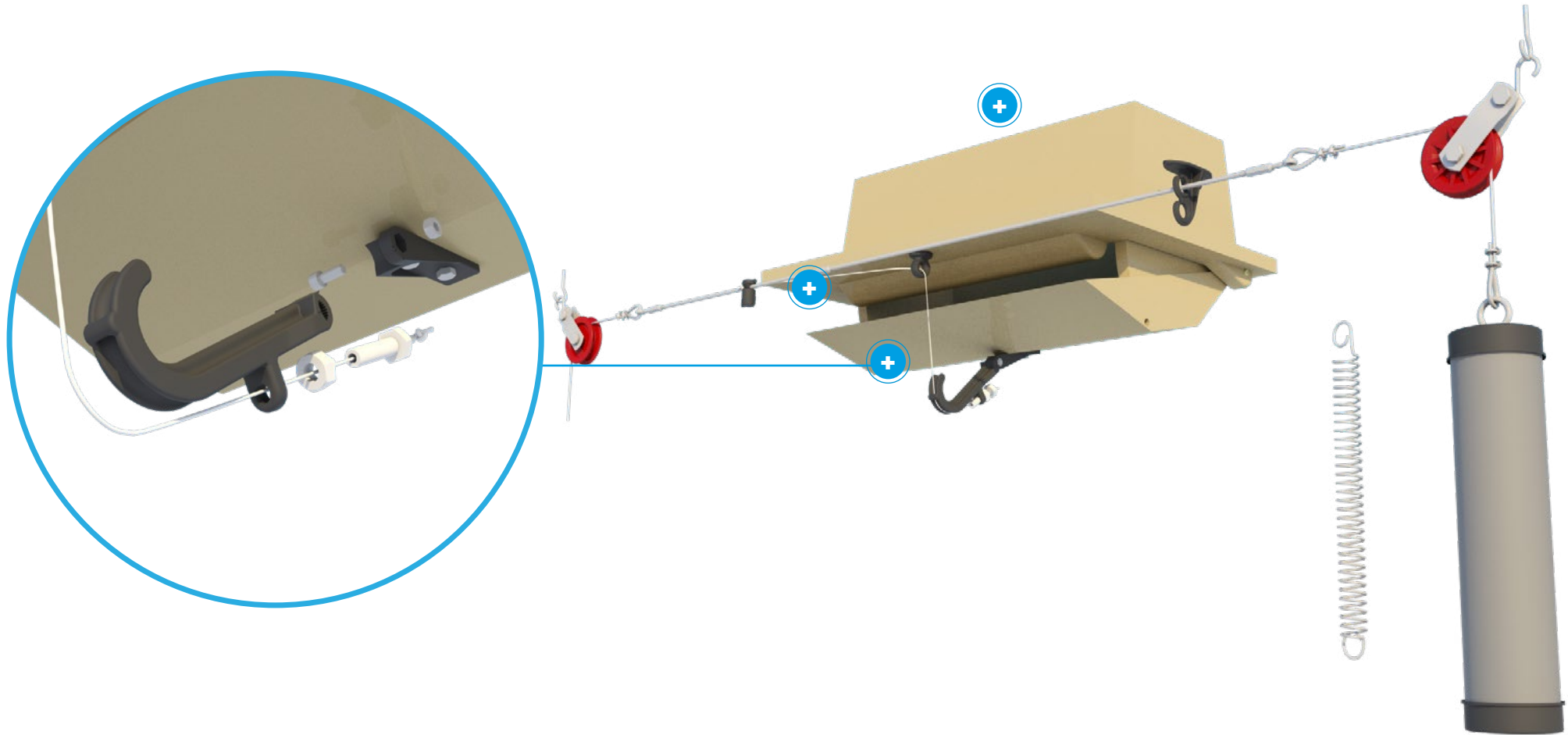

INFO

DATASHEET

ASSEMBLY

MOUNTING

WORKING

MAINTENANCE



All sizes are in cm and inches

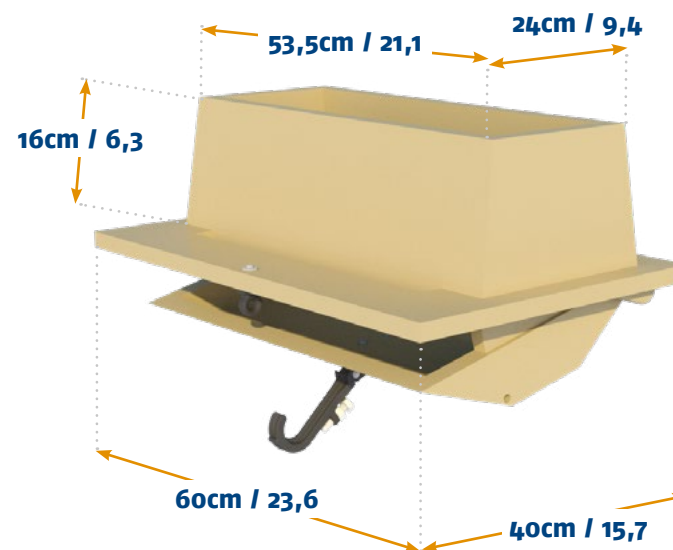
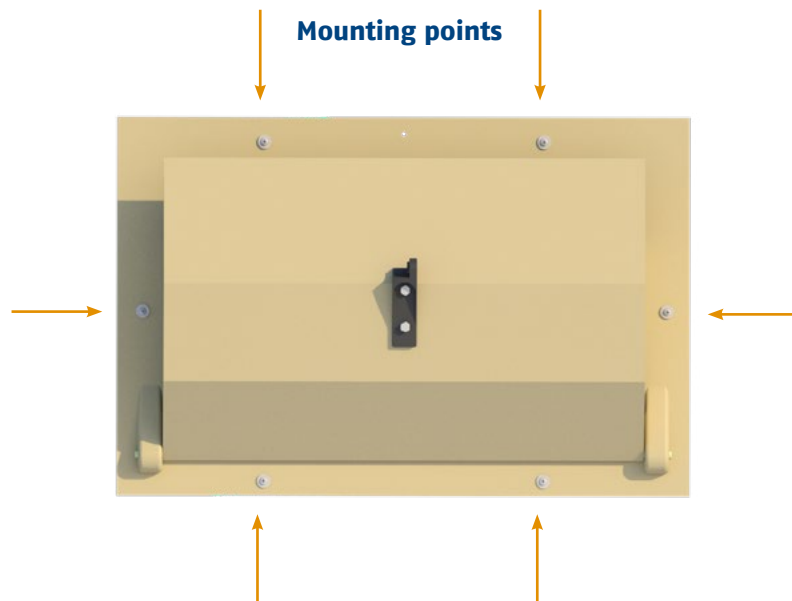

MOUNTING

Mounting type	Ceiling
Mounting hole size	55,5 cm / 21,85 inch x 26 cm / 10,24 inch



INFO

DATASHEET

ASSEMBLY

MOUNTING

WORKING

MAINTENANCE



AIR FLOW

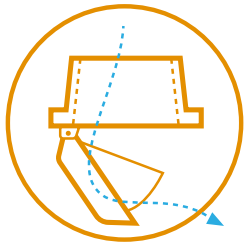
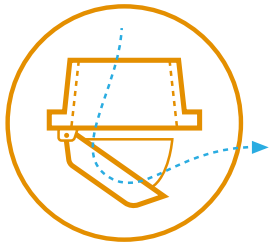

Ceiling Inlets

Our ceiling inlets are curved to offer a good throw of air that follows the ceiling and then drops down gradually. The seals all around the house prevent air leakage when the inlets are closed. These inlets do not use springs but open with the natural pull of gravity.

Working with end-weights or springs

We offer two products which can be used to keep tension on the main cable. A PVC cylinder which can be filled with concrete or sand to act as end-weight, or a spring that holds tension on the cable.

Pre-heating

The advantage of ceiling inlets is that the incoming air can be pre-heated in the attic of the house before entering the area where the animals are located.

[INFO](#)
[DATASHEET](#)
[ASSEMBLY](#)
[MOUNTING](#)
[WORKING](#)
[MAINTENANCE](#)

120-P-C

This inlet is specially designed for installation in ceilings. The inlet is used to bring air from the attic into the house. Working with ceiling inlets, in turn, helps to pre-heat the temperature of incoming air. The inlet is controlled by means of a central plastic arm.

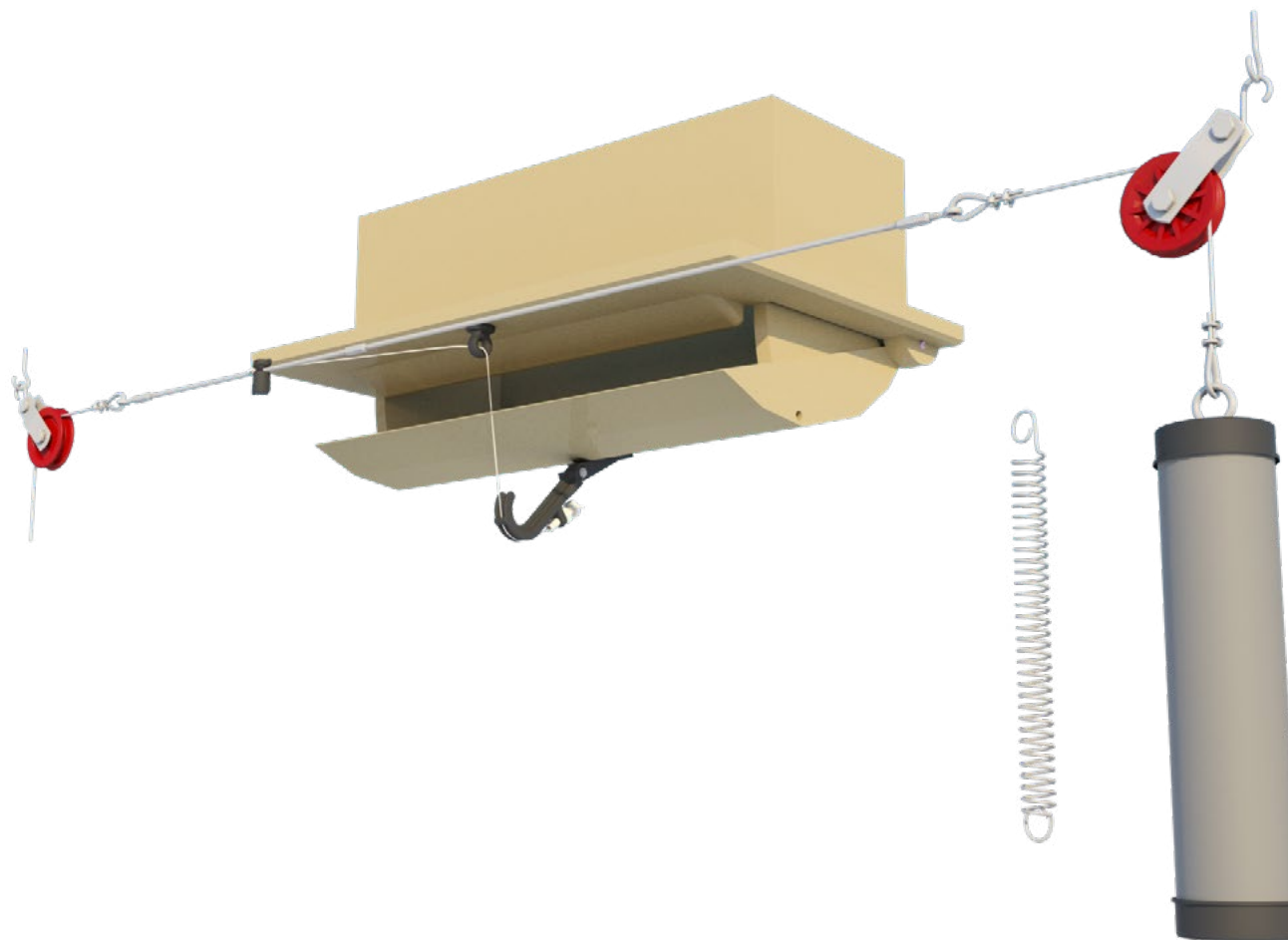

INFO

DATASHEET

ASSEMBLY

MOUNTING

WORKING

MAINTENANCE





120-P-C DATASHEET



CAPACITY

Model	m ³ /h @ 10 Pa	m ³ /h @ 20 Pa	m ³ /h @ 40 Pa
120-P-C	1100	1560	2200
	cfm @ 0.05 inH ₂ O	cfm @ 0.1 inH ₂ O	cfm @ 0.15 inH ₂ O
	724	1025	1250

INFORMATION

Run	20 cm / 7.9 inch
Force	1,5 kg / 14.7 Newton
Number / pallet (1.20 x 0.80 x 2.40 m)	24
Weight / per inlet	2,2 kg / 4.9 lbs
Volume / per box	8
Arm position	3

OPTIONAL ACCESSORIES

TPI-204c	Connection set
TPI-745	Extension piece

AIR FLOW

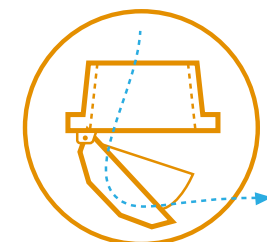
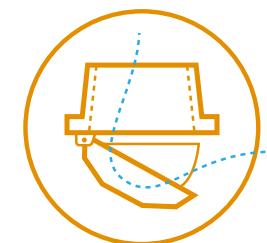
[INFO](#)[DATASHEET](#)[ASSEMBLY](#)[MOUNTING](#)[WORKING](#)[MAINTENANCE](#)



TPI-745

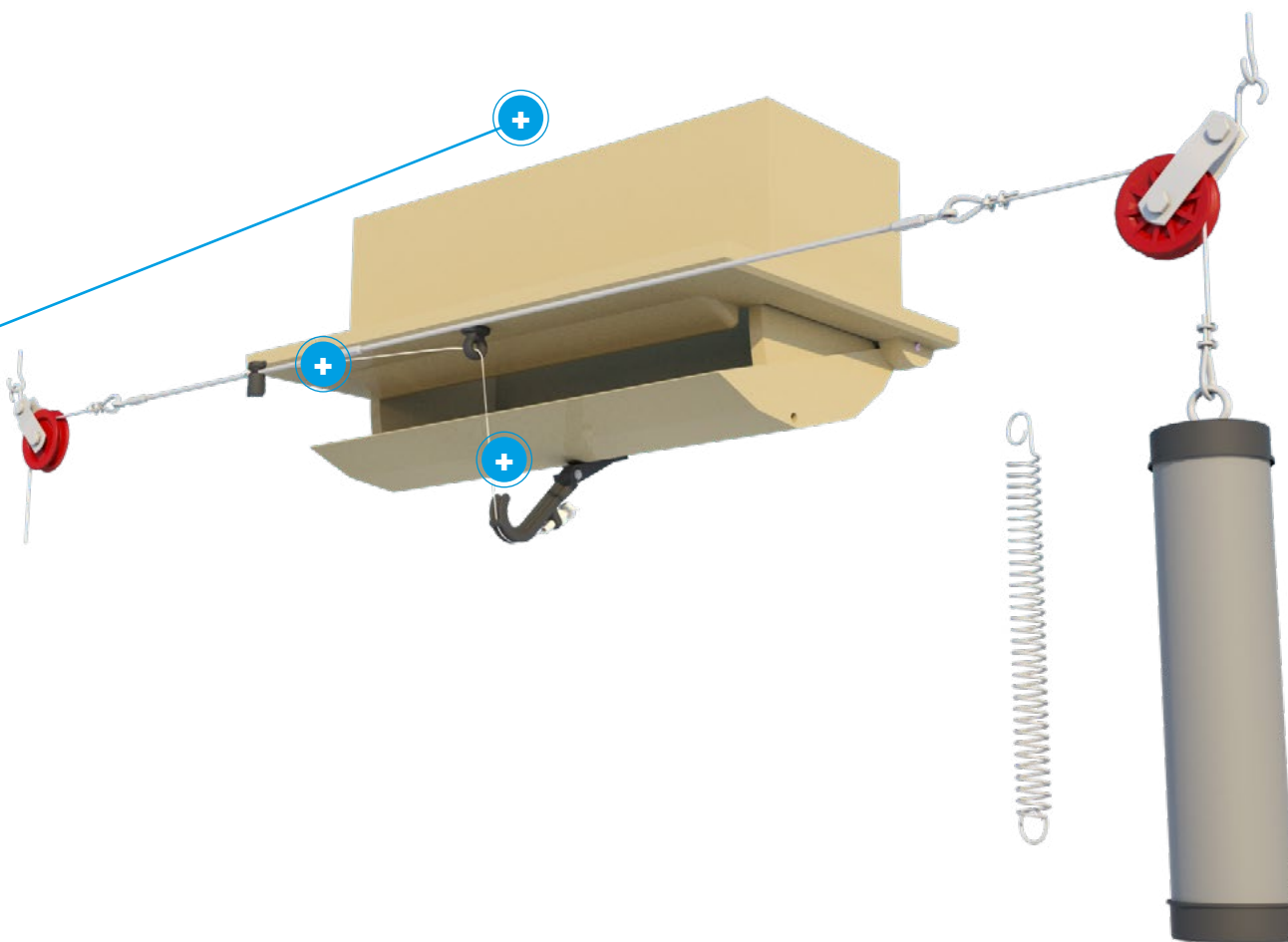

INFO

DATASHEET

ASSEMBLY

MOUNTING

WORKING

MAINTENANCE



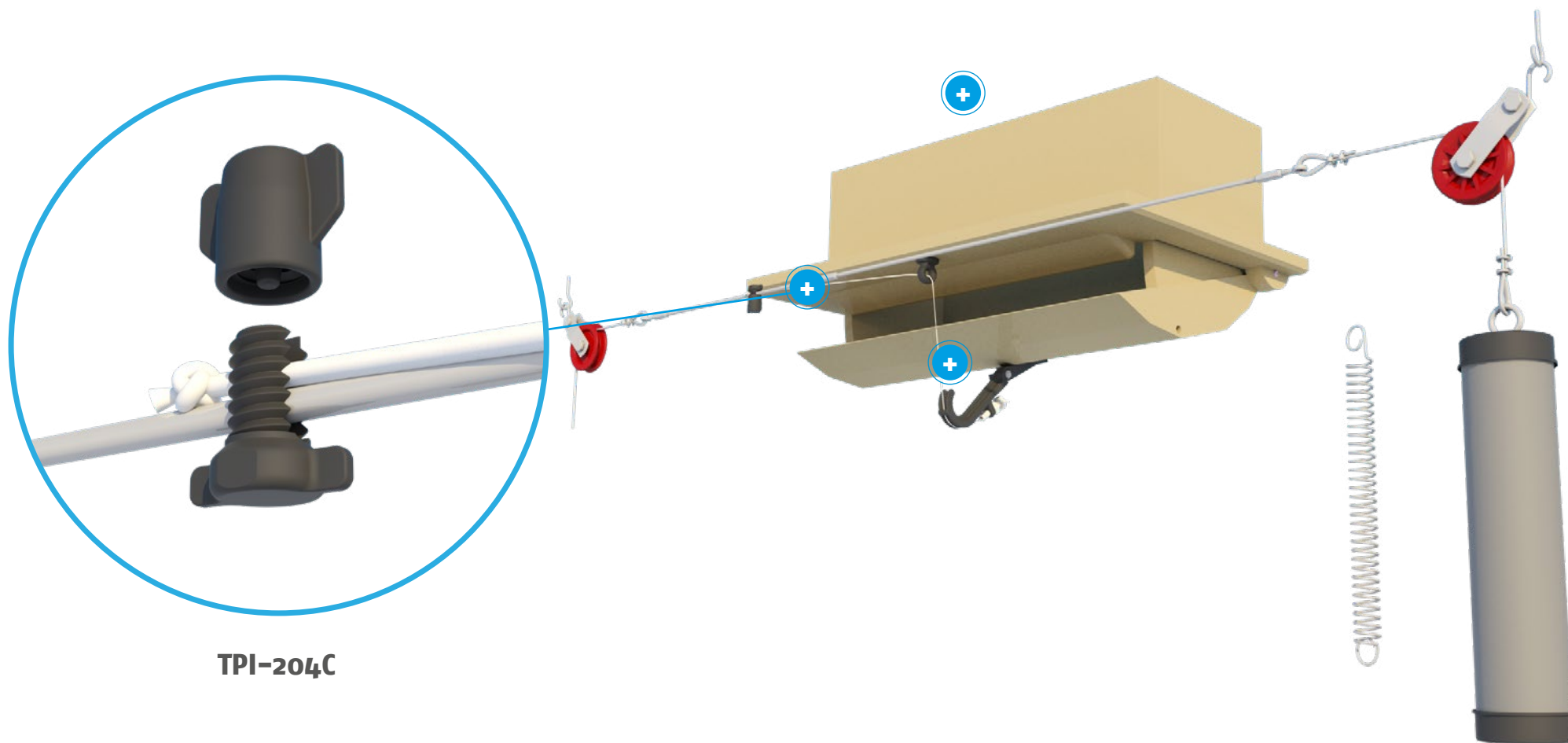

TPI-204C

INFO

DATASHEET

ASSEMBLY

MOUNTING

WORKING

MAINTENANCE



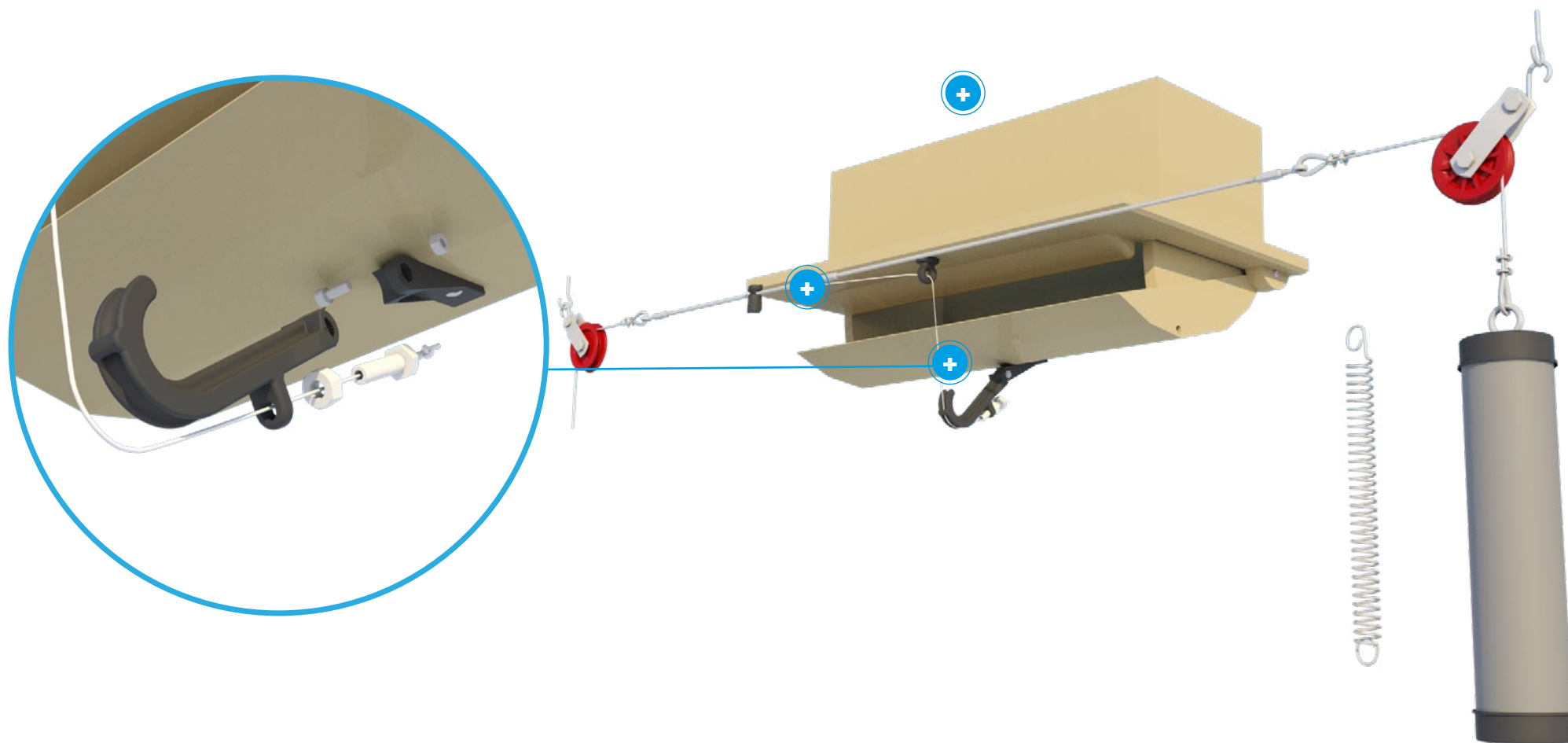

INFO

DATASHEET

ASSEMBLY

MOUNTING

WORKING

MAINTENANCE



All sizes are in cm and inches

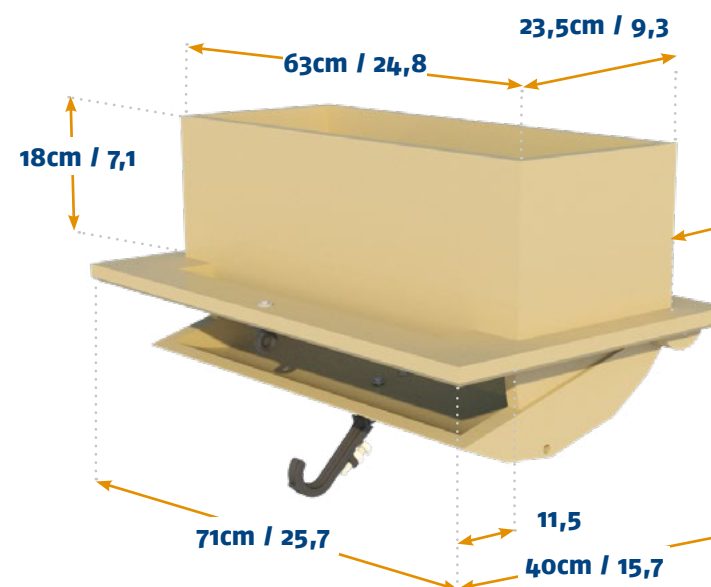
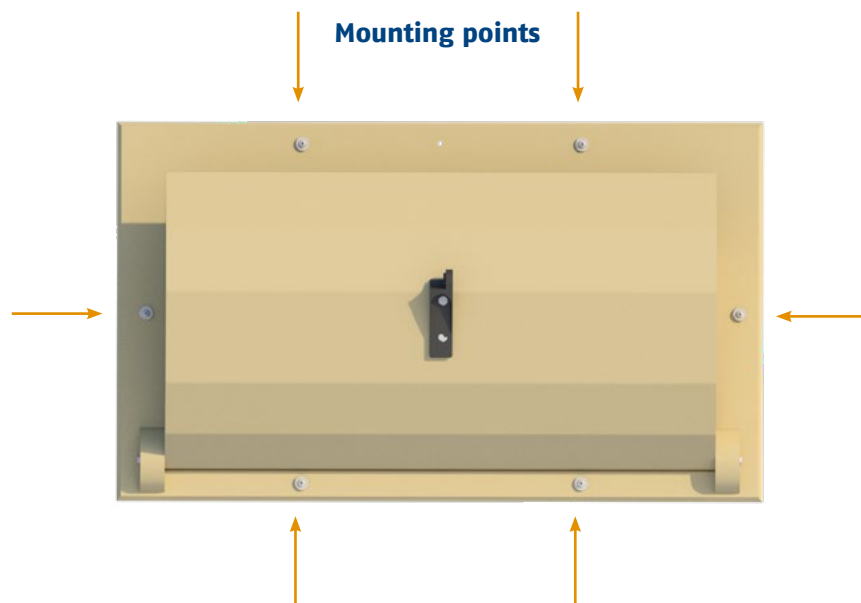

MOUNTING

Mounting type	Ceiling
Mounting hole size	65 cm / 25,59 inch x 25,5 cm / 10,04 inch



[INFO](#)

[DATASHEET](#)

[ASSEMBLY](#)

MOUNTING

[WORKING](#)

[MAINTENANCE](#)



AIR FLOW

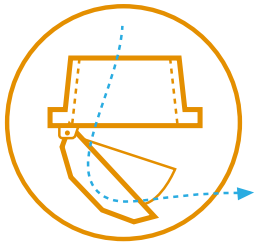
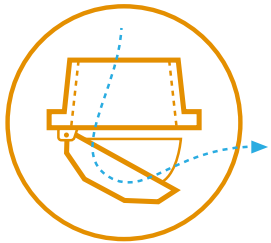

Ceiling Inlets

Our ceiling inlets are curved to offer a good throw of air that follows the ceiling and then drops down gradually. The seals all around the house prevent air leakage when the inlets are closed. These inlets do not use springs but open with the natural pull of gravity.

Working with end-weights or springs

We offer two products which can be used to keep tension on the main cable. A PVC cylinder which can be filled with concrete or sand to act as end-weight, or a spring that holds tension on the cable.

Pre-heating

The advantage of ceiling inlets is that the incoming air can be pre-heated in the attic of the house before entering the area where the animals are located.

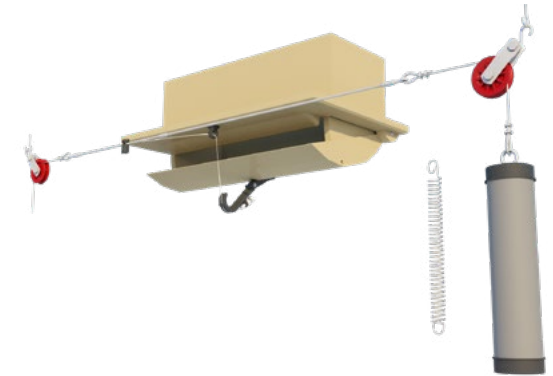

INFO

DATASHEET

ASSEMBLY

MOUNTING

WORKING

MAINTENANCE



160-P-C

This inlet is specially designed for installation in ceilings. The inlet is used to bring air from the attic into the house. Working with ceiling inlets, in turn, helps to pre-heat the temperature of incoming air. The inlet is controlled by means of a central plastic arm.

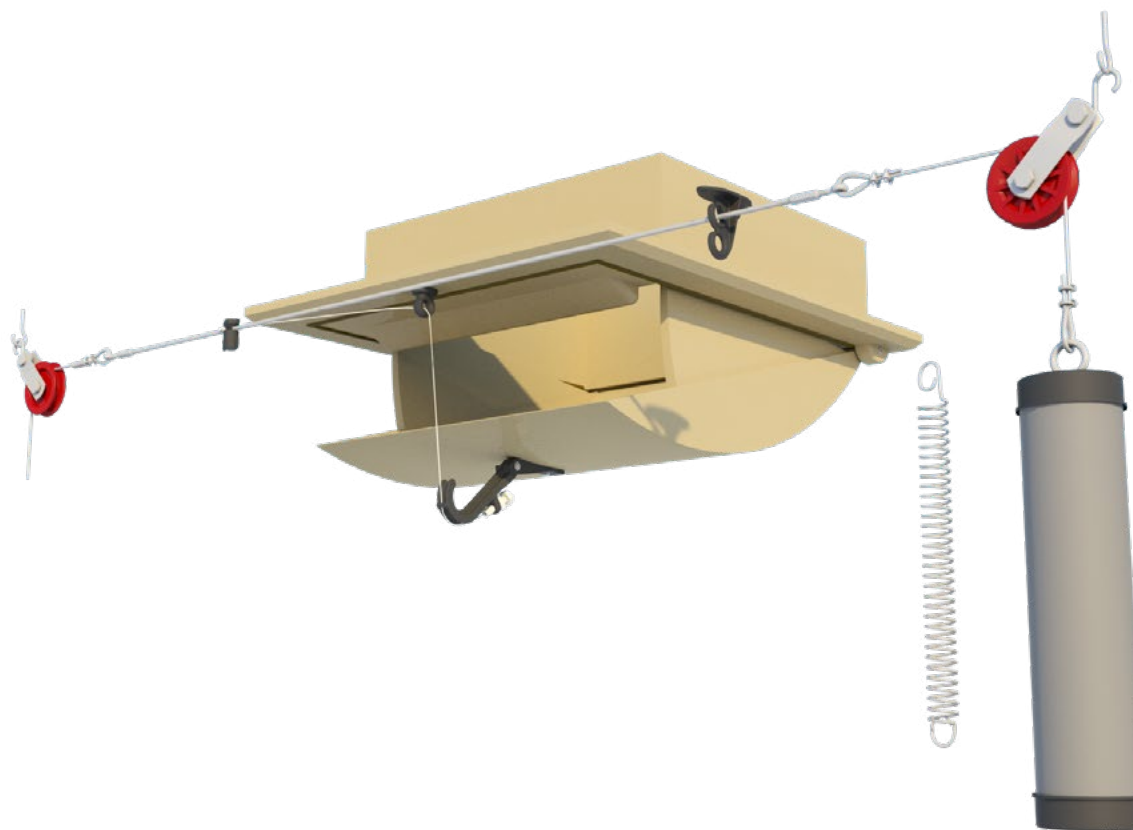

INFO

DATASHEET

ASSEMBLY

MOUNTING

WORKING

MAINTENANCE





160-P-C DATASHEET



CAPACITY

Model	m ³ /h @ 10 Pa	m ³ /h @ 20 Pa	m ³ /h @ 40 Pa
160-P-C	1600	2250	3200
	cfm @ 0.05 inH ₂ O	cfm @ 0.1 inH ₂ O	cfm @ 0.15 inH ₂ O
	1053	1478	1819

INFORMATION

Run	20 cm / 7.9 inch
Force	1,5 kg / 14.7 Newton
Number / pallet (1.20 x 1.00 x 2.40 m)	32
Weight / per inlet	2,9 kg / 6.4 lbs
Volume / per box	16
Arm position	2

OPTIONAL ACCESSORIES

TPI-204c	Connection set
TPI-746	Extension piece

AIR FLOW

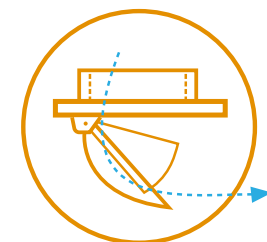
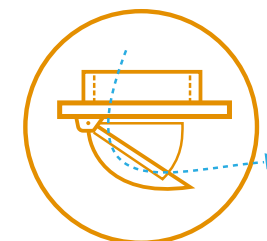
[INFO](#)[DATASHEET](#)[ASSEMBLY](#)[MOUNTING](#)[WORKING](#)[MAINTENANCE](#)

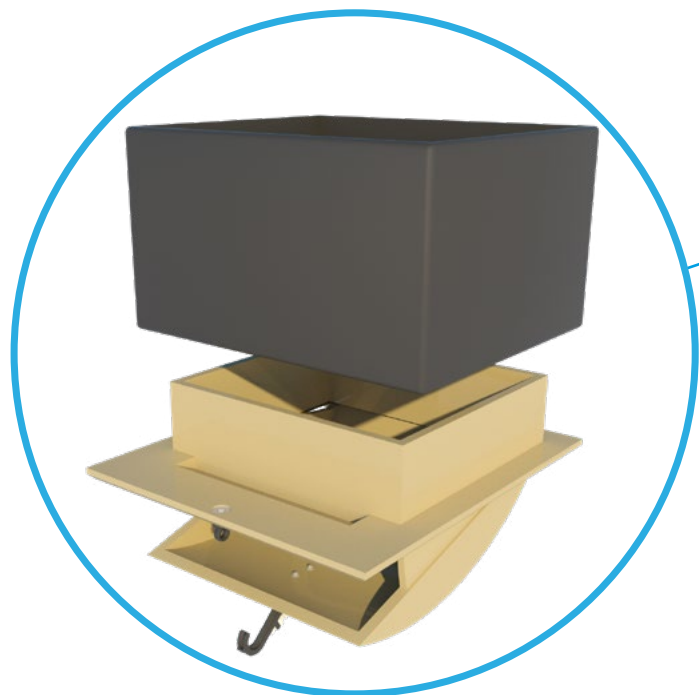

TPI-746

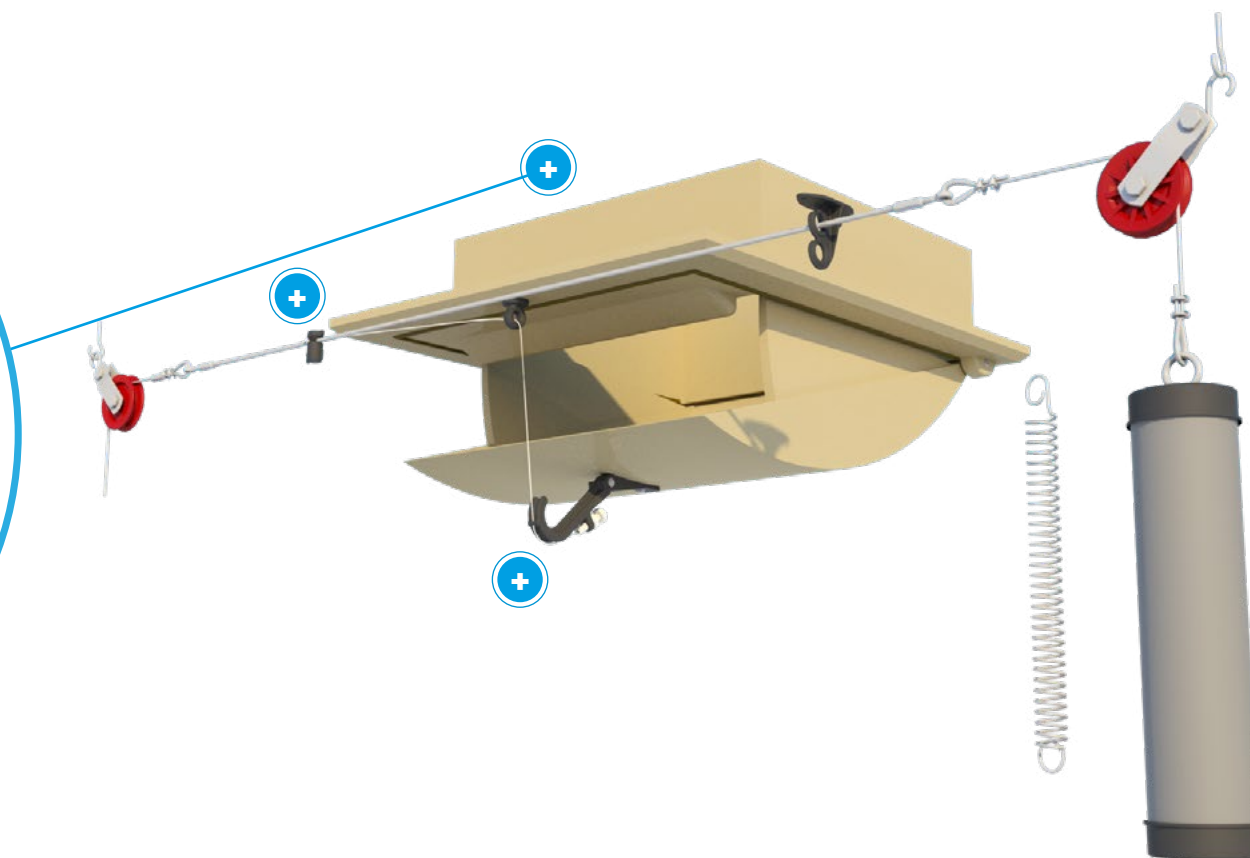



TPI-204C

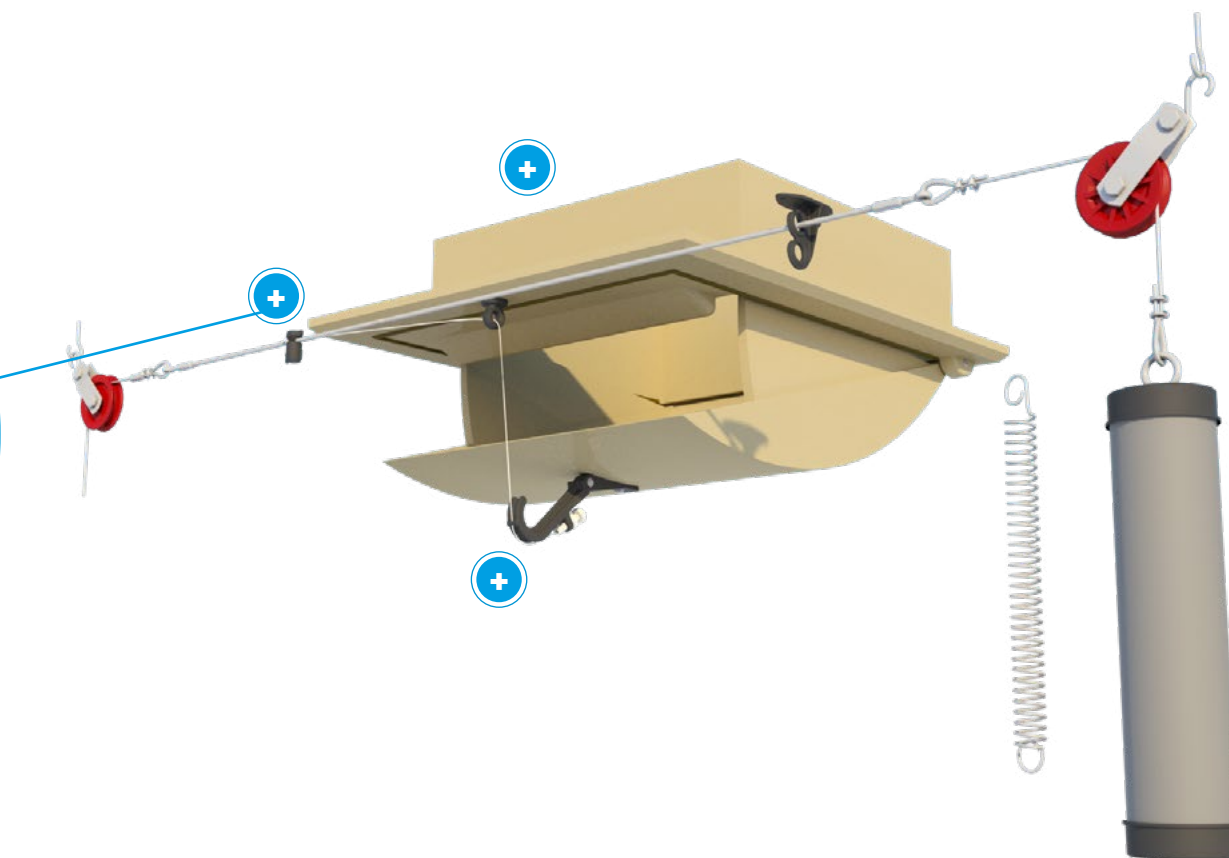

INFO

DATASHEET

ASSEMBLY

MOUNTING

WORKING

MAINTENANCE



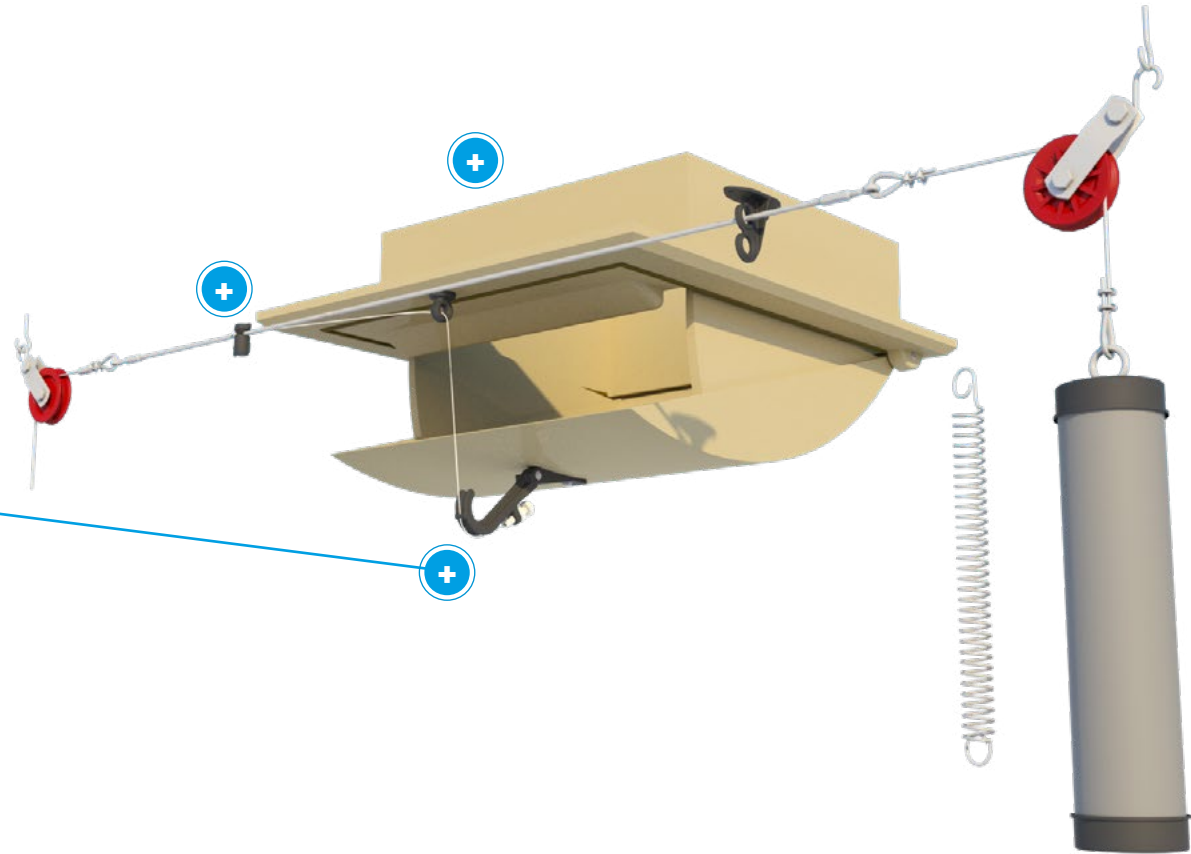

INFO

DATASHEET

ASSEMBLY

MOUNTING

WORKING

MAINTENANCE



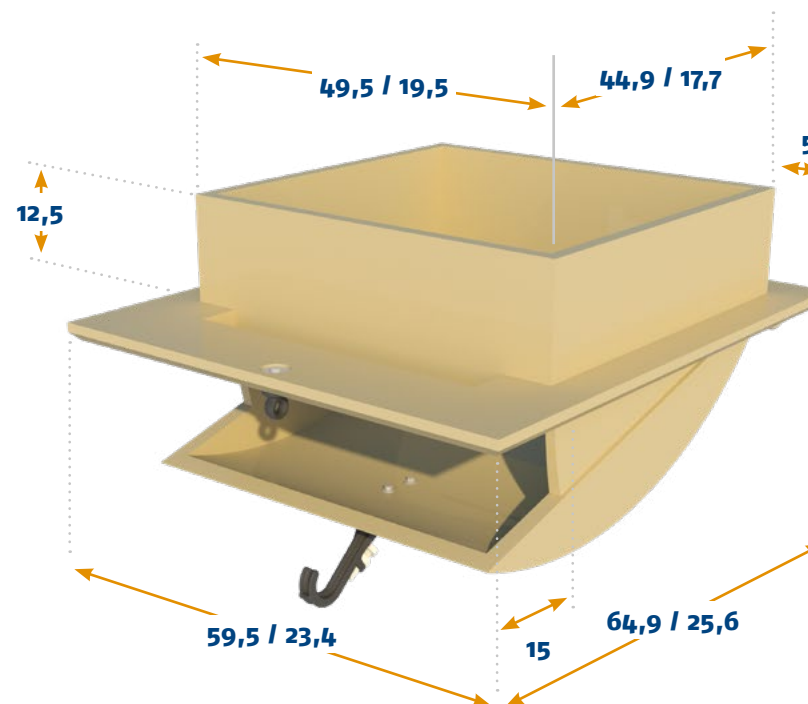
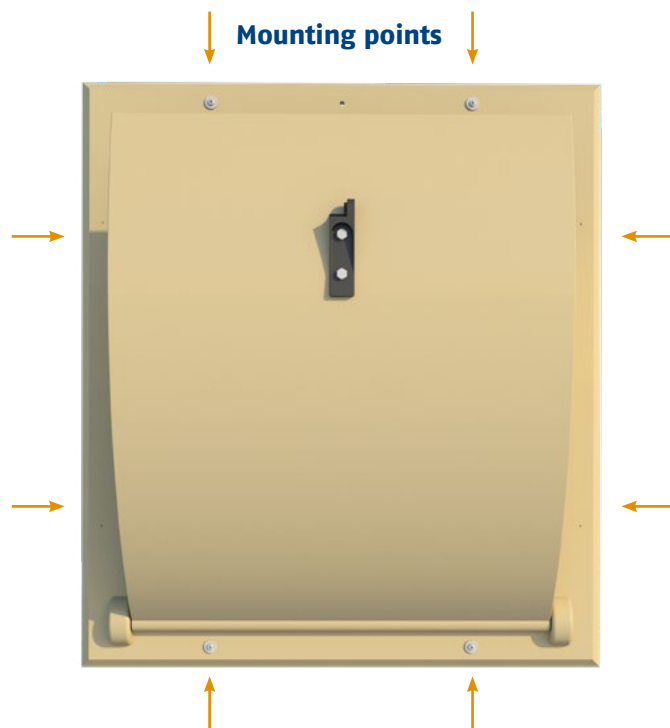

All sizes are in cm and inches

MOUNTING

Mounting type	Ceiling
Mounting hole size	51,5 cm / 20,28 inch x 47 cm / 18,50 inch



[INFO](#)

[DATASHEET](#)

[ASSEMBLY](#)

MOUNTING

[WORKING](#)

[MAINTENANCE](#)



AIR FLOW

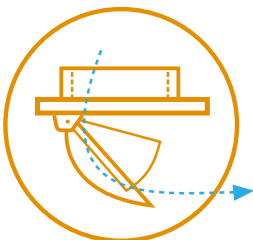
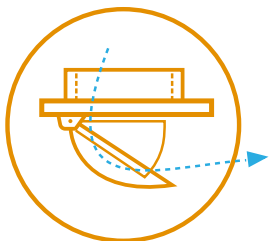

Ceiling Inlets

Our ceiling inlets are curved to offer a good throw of air that follows the ceiling and then drops down gradually. The seals all around the house prevent air leakage when the inlets are closed. These inlets do not use springs but open with the natural pull of gravity.

Working with end-weights or springs

We offer two products which can be used to keep tension on the main cable. A PVC cylinder which can be filled with concrete or sand to act as end-weight, or a spring that holds tension on the cable.

Pre-heating

The advantage of ceiling inlets is that the incoming air can be pre-heated in the attic of the house before entering the area where the animals are located.

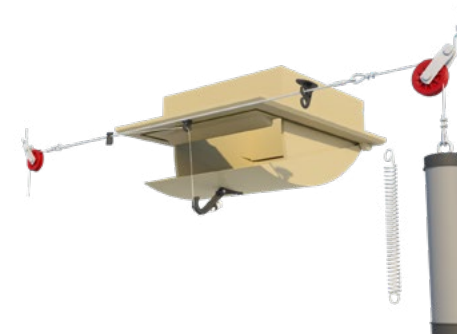

INFO

DATASHEET

ASSEMBLY

MOUNTING

WORKING

MAINTENANCE



160-PD-C

This inlet is specially designed for installation in ceilings. The inlet is used to bring air from the attic into the house. Working with ceiling inlets, in turn, helps to pre-heat the temperature of incoming air. The inlet is controlled by means of a central plastic arm. This is the double version of the 160-P-C inlet and it can direct air into two opposite directions.

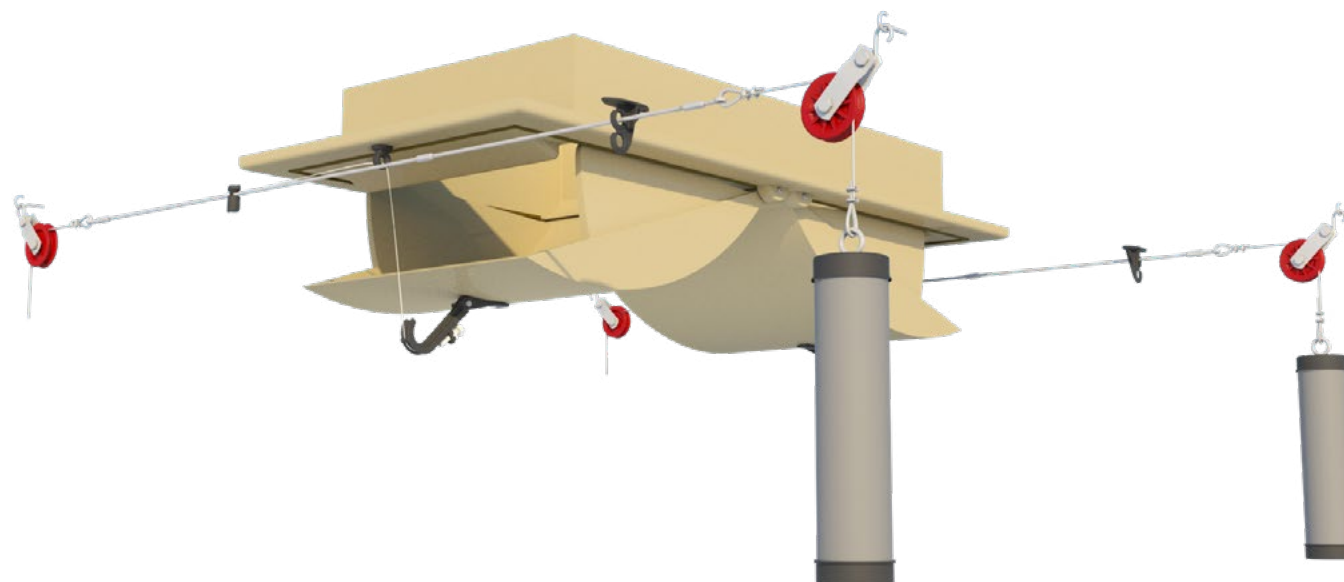

[INFO](#)

[DATASHEET](#)

[ASSEMBLY](#)

[MOUNTING](#)

[WORKING](#)

[MAINTENANCE](#)





160-PD-C DATASHEET



CAPACITY

Model	m ³ /h @ 10 Pa	m ³ /h @ 20 Pa	m ³ /h @ 40 Pa
160-PD-C	3200	4500	6400
	cfm @ 0.05 inH ₂ O	cfm @ 0.1 inH ₂ O	cfm @ 0.15 inH ₂ O
	2106	2955	3638

INFORMATION

Run	28 cm / 11 inch
Force	3 kg / 29.4 Newton
Number / pallet (1.30 x 1.00 x 2.50 m)	16
Weight / per inlet	5,4 kg / 11.9 lbs
Volume / per box	8
Arm position	2

OPTIONAL ACCESSORIES

TPI-204c (*2)	Connection set
TPI-747	Extension piece

AIR FLOW

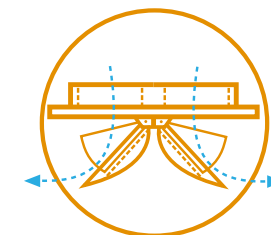
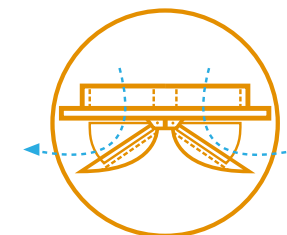
[INFO](#)[DATASHEET](#)[ASSEMBLY](#)[MOUNTING](#)[WORKING](#)[MAINTENANCE](#)

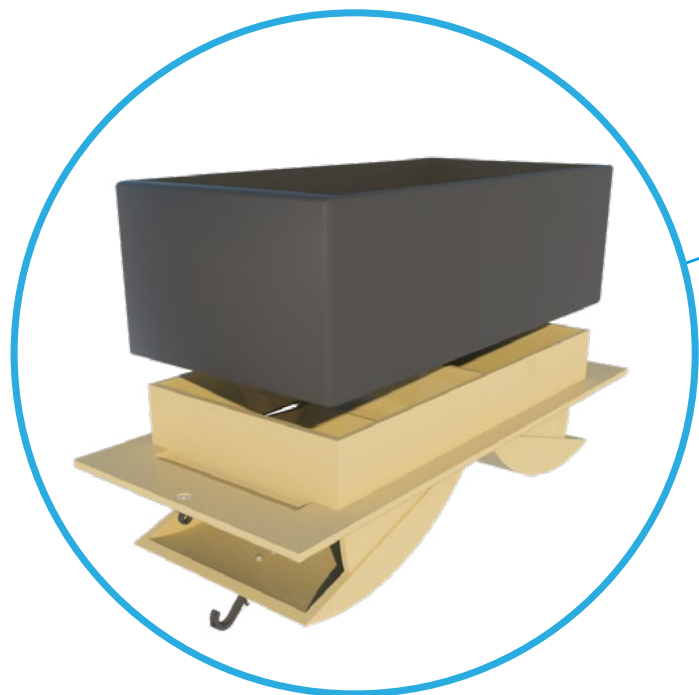

TPI-747

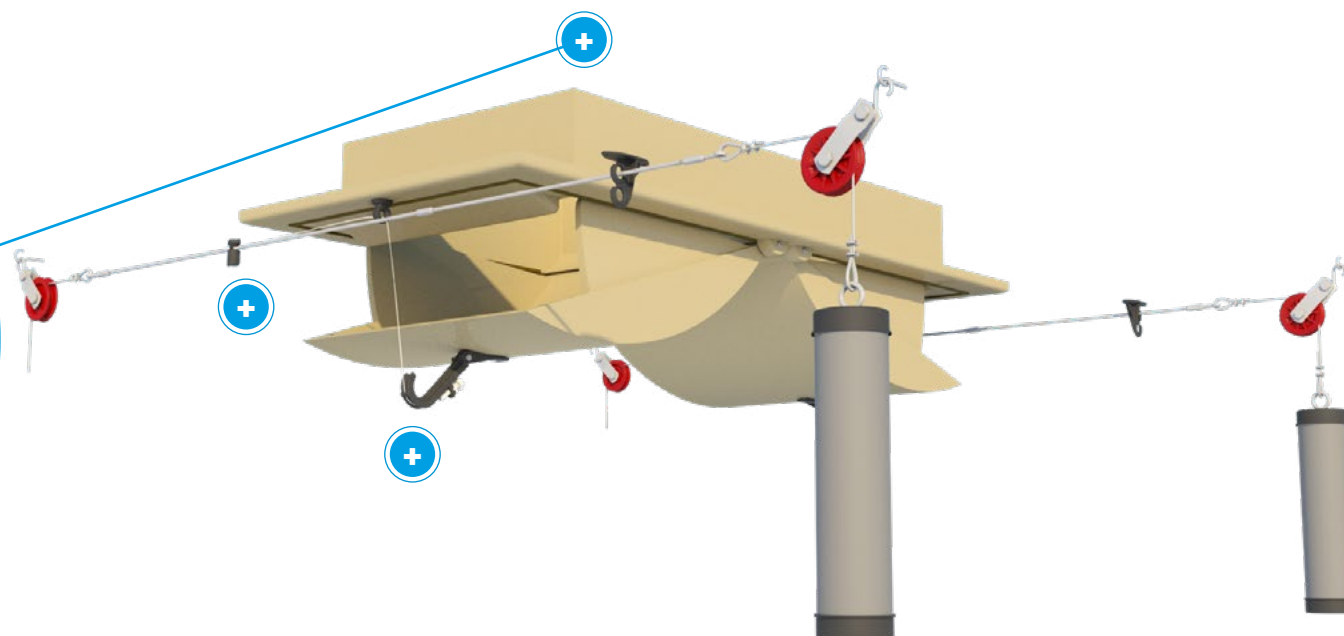

INFO

DATASHEET

ASSEMBLY

MOUNTING

WORKING

MAINTENANCE



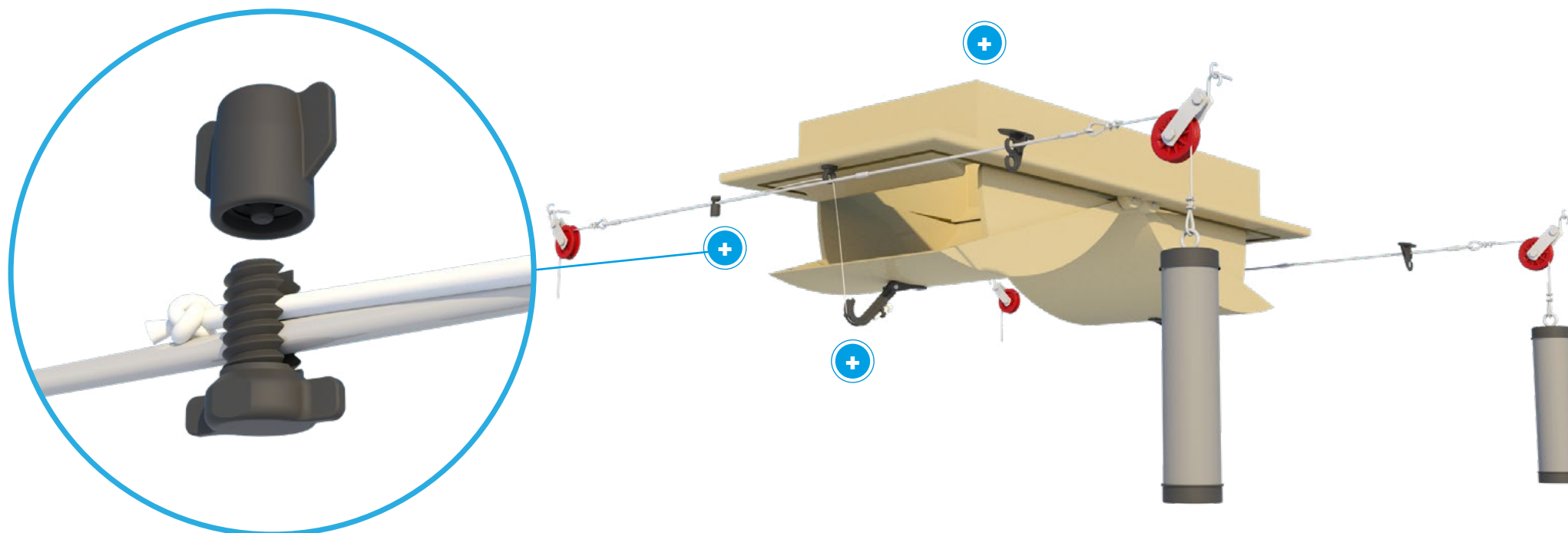

TPI-204C

INFO

DATASHEET

ASSEMBLY

MOUNTING

WORKING

MAINTENANCE



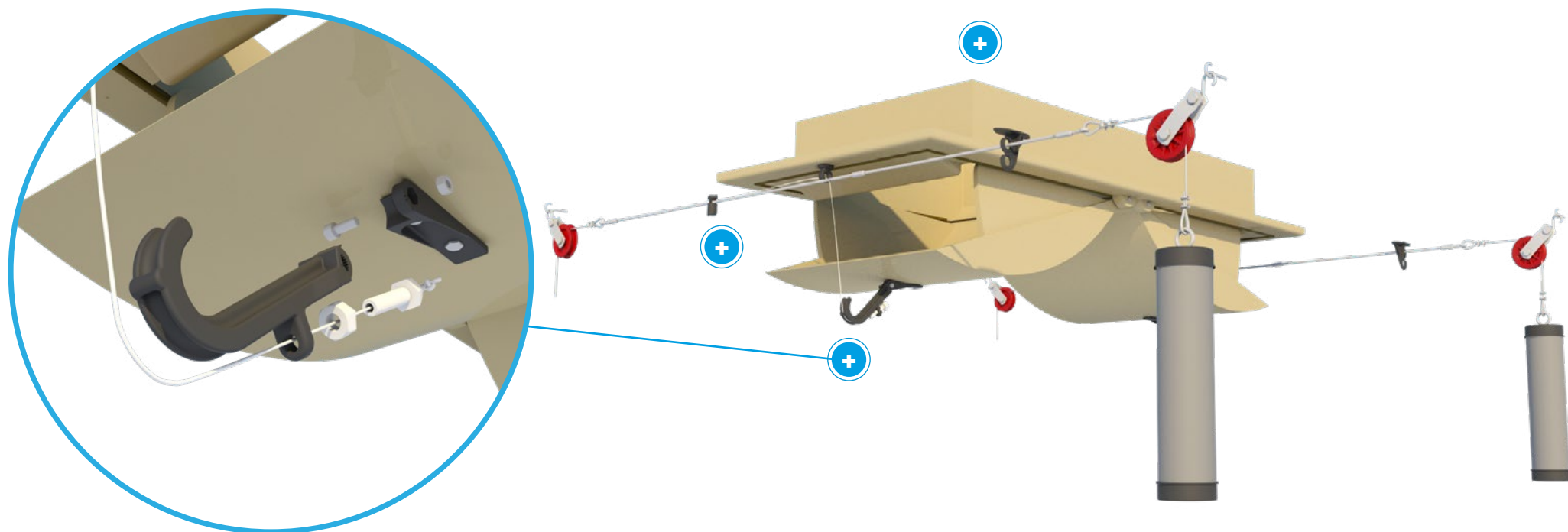

Mounting points

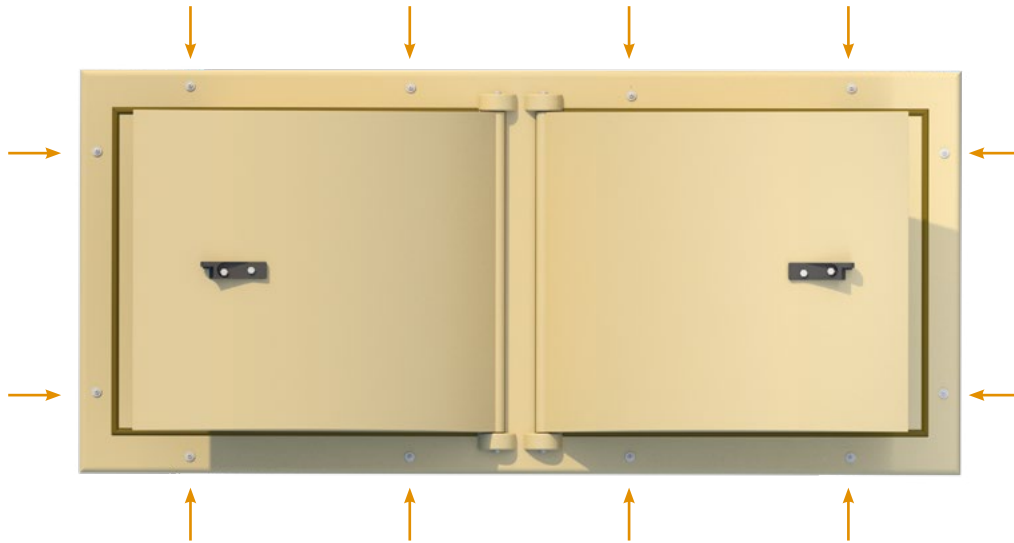

All sizes are in cm and inches

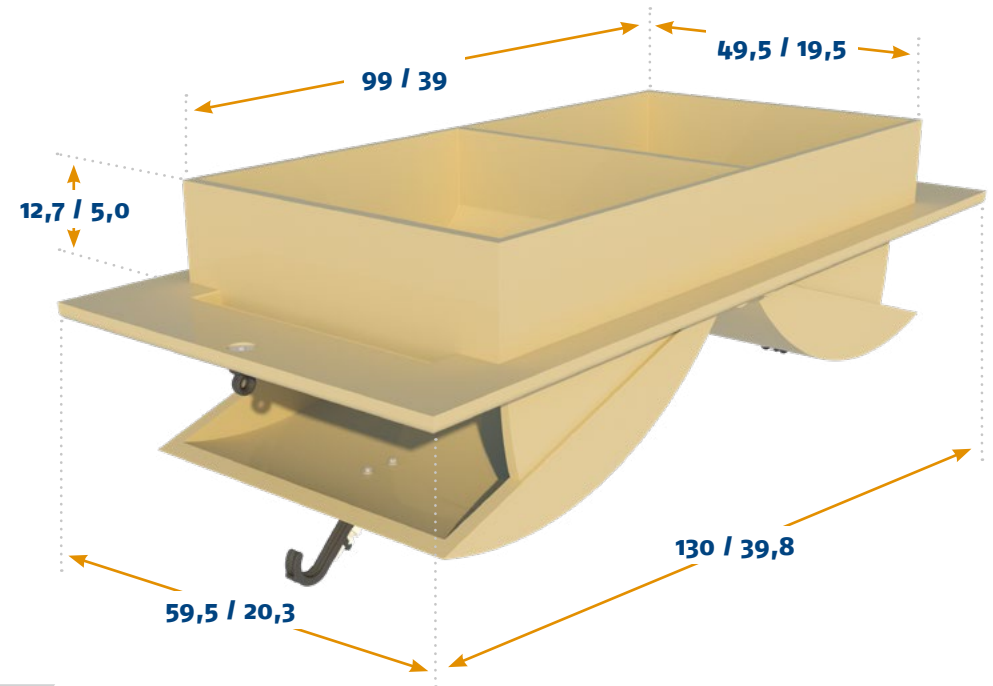

MOUNTING

Mounting type	Ceiling
Mounting hole size	51,5 cm / 20,28 inch X 101 cm / 39,76 inch



[INFO](#)

[DATASHEET](#)

[ASSEMBLY](#)

[MOUNTING](#)

[WORKING](#)

[MAINTENANCE](#)



AIR FLOW

Ceiling Inlets

Our ceiling inlets are curved to offer a good throw of air that follows the ceiling and then drops down gradually. The seals all around the house prevent air leakage when the inlets are closed. These inlets do not use springs but open with the natural pull of gravity.

Working with end-weights or springs

We offer two products which can be used to keep tension on the main cable. A PVC cylinder which can be filled with concrete or sand to act as end-weight, or a spring that holds tension on the cable.

Pre-heating

The advantage of ceiling inlets is that the incoming air can be pre-heated in the attic of the house before entering the area where the animals are located.

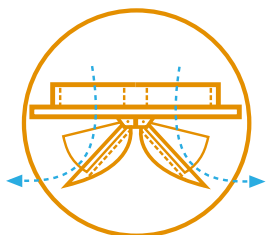
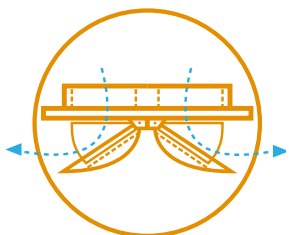

INFO

DATASHEET

ASSEMBLY

MOUNTING

WORKING

MAINTENANCE



180-P-C

This inlet is specially designed for installation in ceilings. The inlet is used to bring air from the attic into the house. Working with ceiling inlets, in turn, helps to pre-heat the temperature of incoming air. The inlet is controlled by means of a central plastic arm.

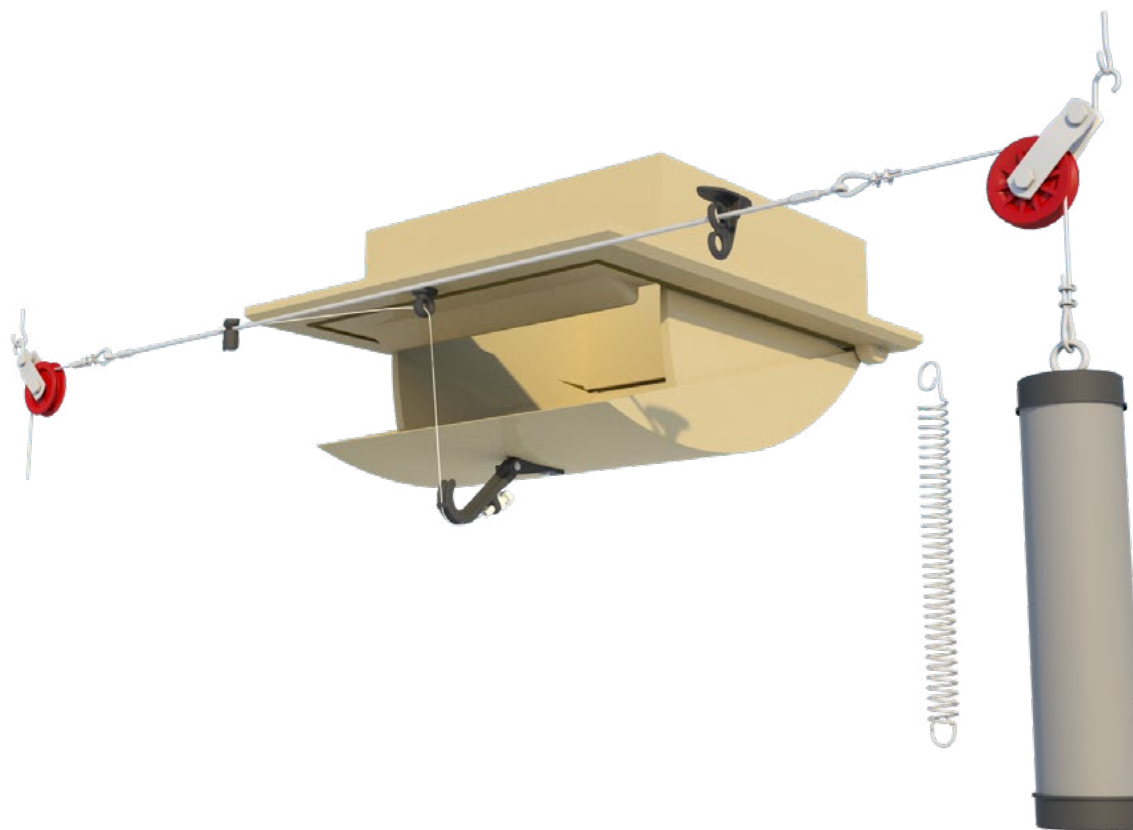

INFO

DATASHEET

ASSEMBLY

MOUNTING

WORKING

MAINTENANCE





180-P-C DATASHEET



CAPACITY

Model	m ³ /h @ 10 Pa	m ³ /h @ 20 Pa	m ³ /h @ 40 Pa
180-P-C	1800	2550	3600
	cfm @ 0.05 inH ₂ O	cfm @ 0.1 inH ₂ O	cfm @ 0.15 inH ₂ O
	1184	1675	2046

INFORMATION

Run	28 cm / 11 inch
Force	2 kg / 19.6 Newton
Number / pallet (1.20 x 1.00 x 2.40 m)	20
Weight / per inlet	3 kg / 6.6 lbs
Volume / per box	10
Arm position	2

OPTIONAL ACCESSORIES

TPI-204c	Connection set
TPI-748	Extension piece

AIR FLOW

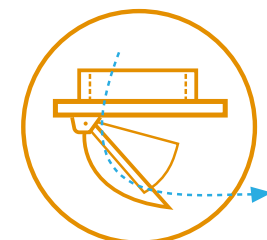
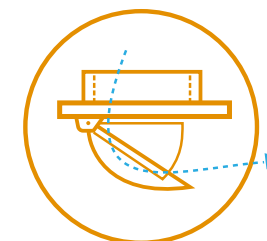

INFO

DATASHEET

ASSEMBLY

MOUNTING

WORKING

MAINTENANCE



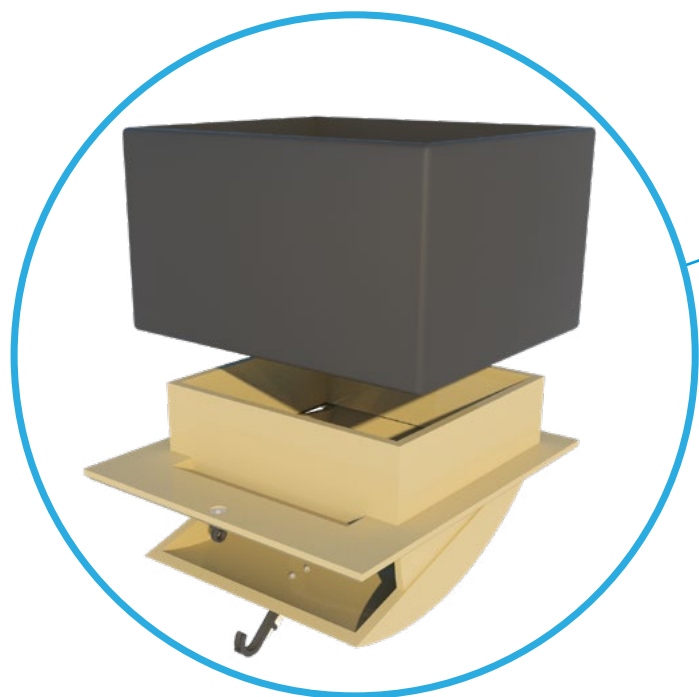

TPI-748

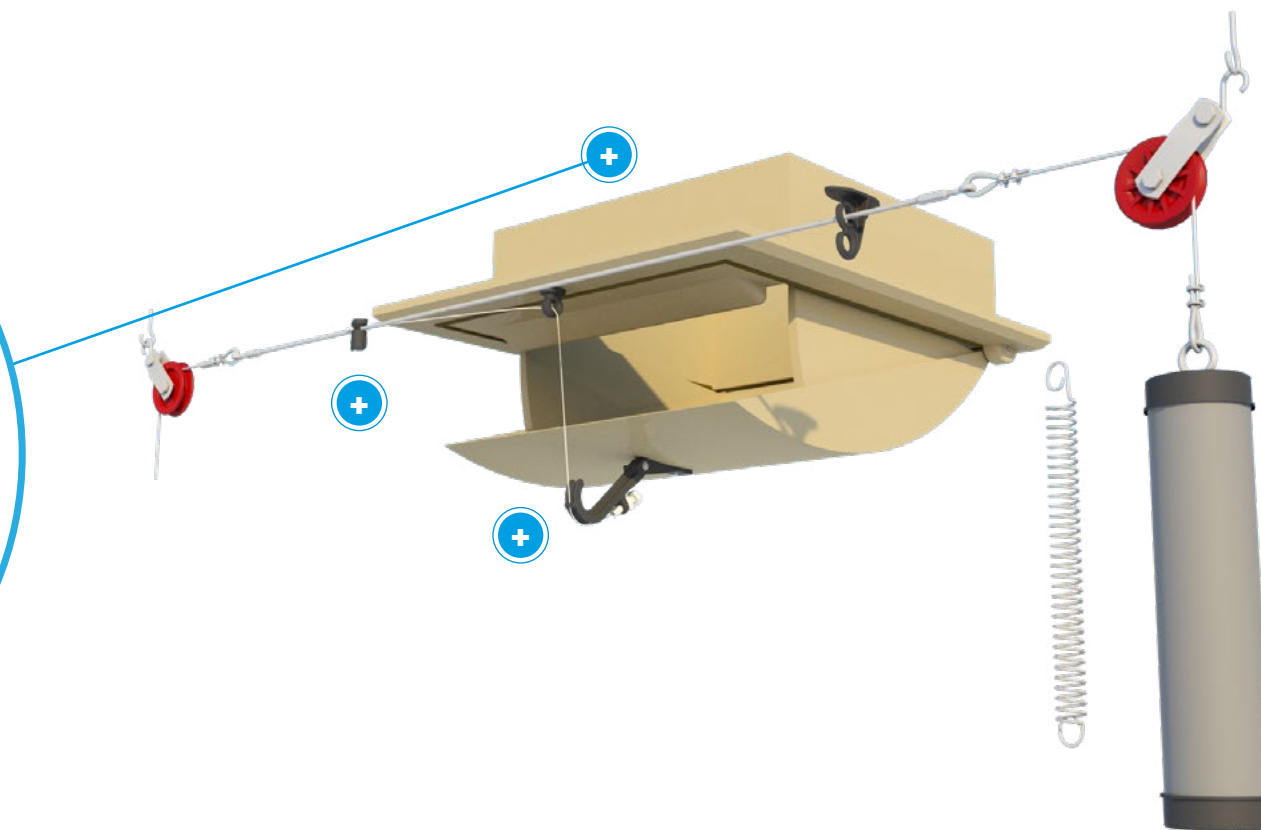



TPI-204C

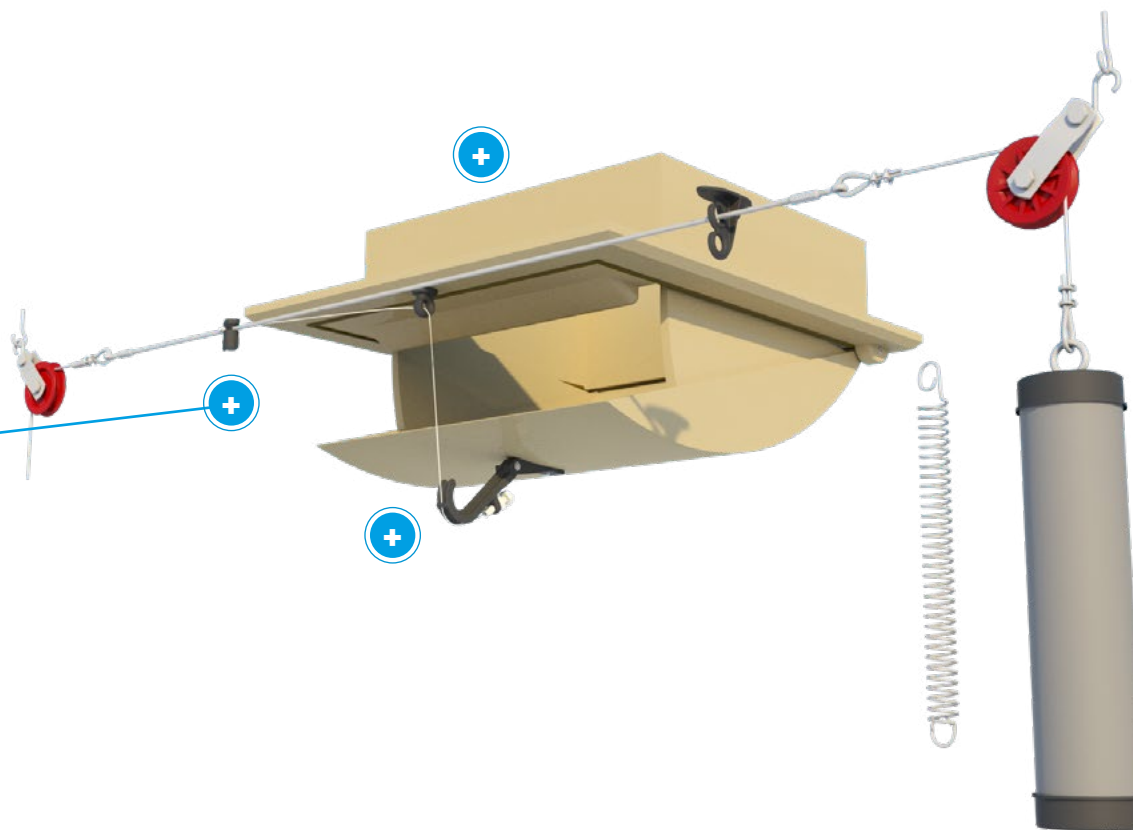

INFO

DATASHEET

ASSEMBLY

MOUNTING

WORKING

MAINTENANCE



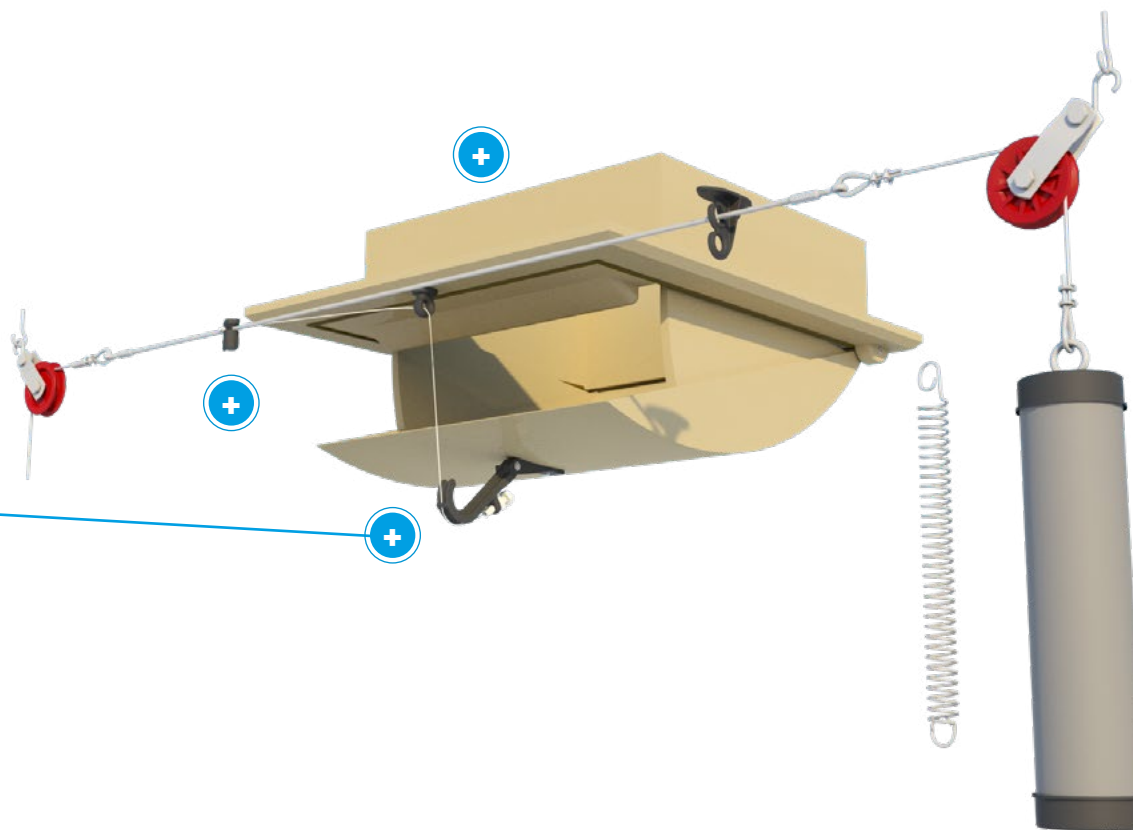

INFO

DATASHEET

ASSEMBLY

MOUNTING

WORKING

MAINTENANCE



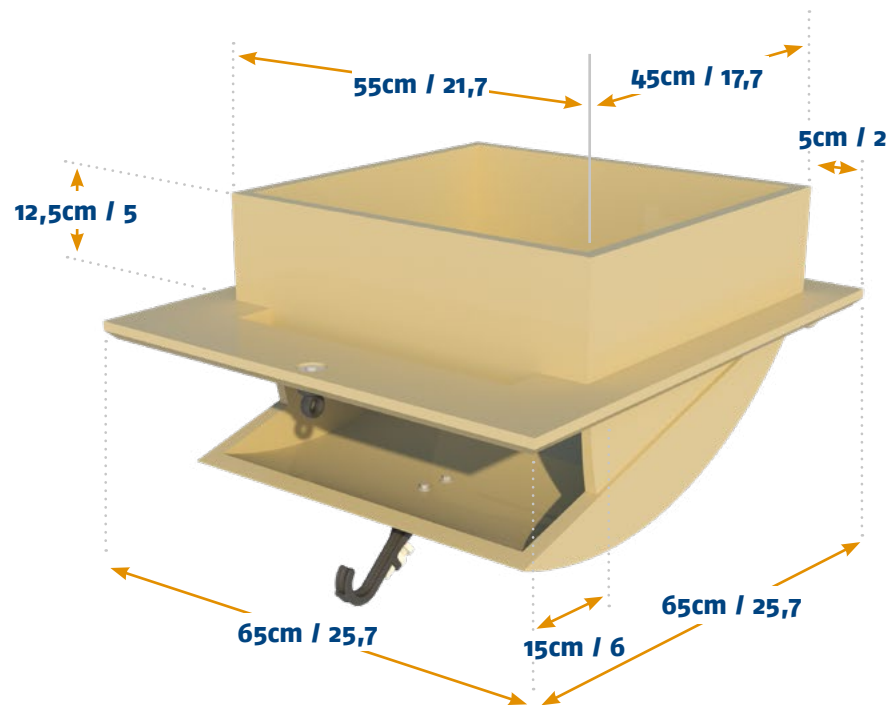
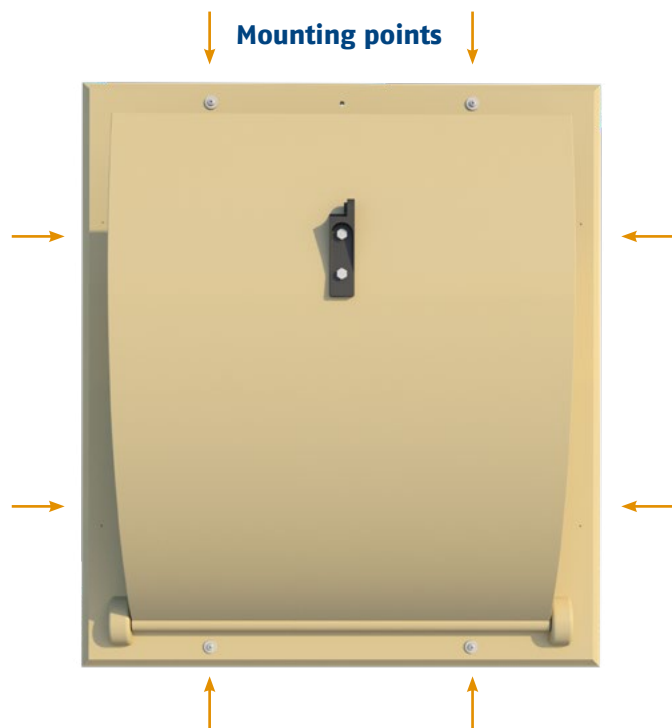

All sizes are in cm and inches

MOUNTING

Mounting type	Ceiling
Mounting hole size	57 cm / 22,44 inch x 47 cm / 18,50 inch



INFO

DATASHEET

ASSEMBLY

MOUNTING

WORKING

MAINTENANCE



AIR FLOW

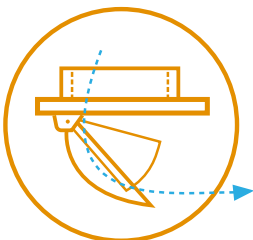
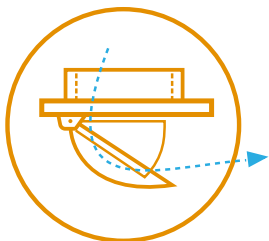

Ceiling Inlets

Our ceiling inlets are curved to offer a good throw of air that follows the ceiling and then drops down gradually. The seals all around the house prevent air leakage when the inlets are closed. These inlets do not use springs but open with the natural pull of gravity.

Working with end-weights or springs

We offer two products which can be used to keep tension on the main cable. A PVC cylinder which can be filled with concrete or sand to act as end-weight, or a spring that holds tension on the cable.

Pre-heating

The advantage of ceiling inlets is that the incoming air can be pre-heated in the attic of the house before entering the area where the animals are located.

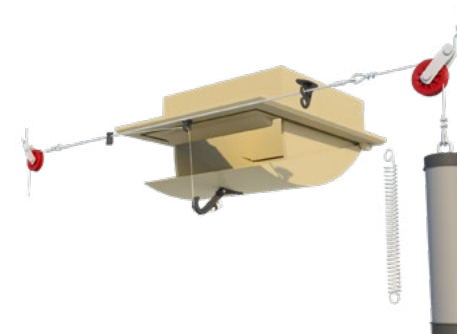

INFO

DATASHEET

ASSEMBLY

MOUNTING

WORKING

MAINTENANCE



220-P

This inlet is specially designed for installation above corridors or pathways, in ceilings. The inlet is used to bring air from the attic into the house. Working with ceiling inlets, in turn, helps to pre-heat the temperature of incoming air. Through this inlet air is channeled directly down to the floor. This inlet has cords connected directly to the two inner flaps.

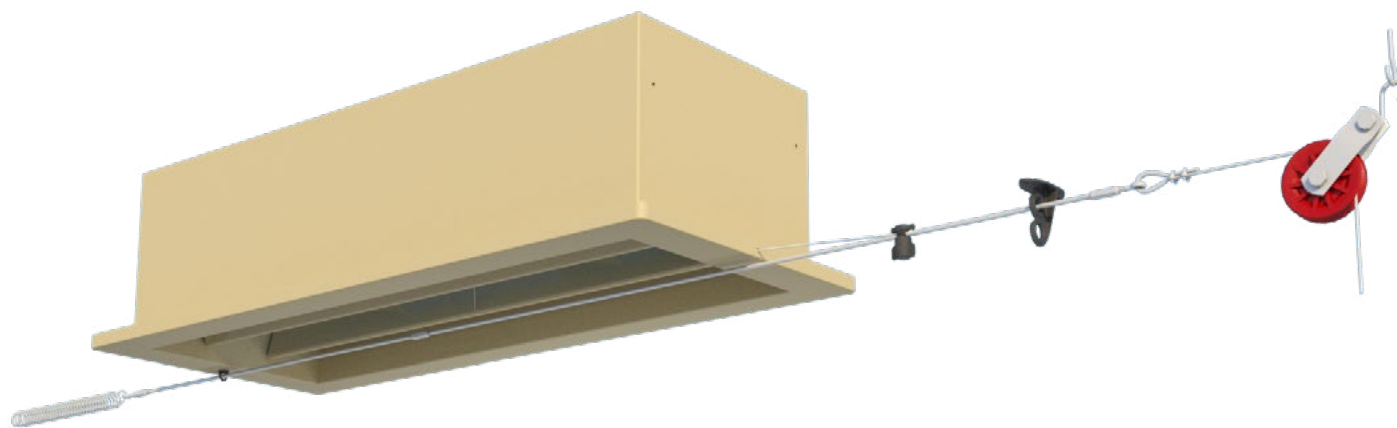

INFO

DATASHEET

ASSEMBLY

MOUNTING

WORKING

MAINTENANCE





220-P DATASHEET



CAPACITY

Model	m ³ /h @ 10 Pa	m ³ /h @ 20 Pa	m ³ /h @ 40 Pa
220-P	2265	2830	3300
	cfm @ 0.05 inH ₂ O	cfm @ 0.1 inH ₂ O	cfm @ 0.15 inH ₂ O
	1490	1859	1876

INFORMATION

Run	10 cm / 3.9 inch
Force	2,2 kg / 21.6 Newton
Number / pallet (1.20 x 1.00 x 2.40 m)	24
Weight / per inlet	4,2 kg / 9.3 lbs
Volume / per box	12

OPTIONAL ACCESSORIES

TPI-621	Cable clamp
---------	-------------

AIR FLOW

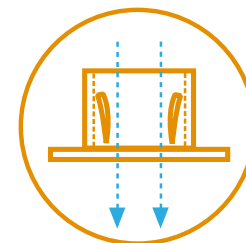
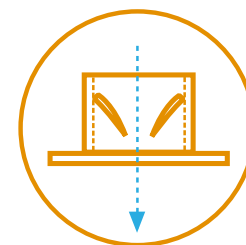

INFO

DATASHEET

ASSEMBLY

MOUNTING

WORKING

MAINTENANCE



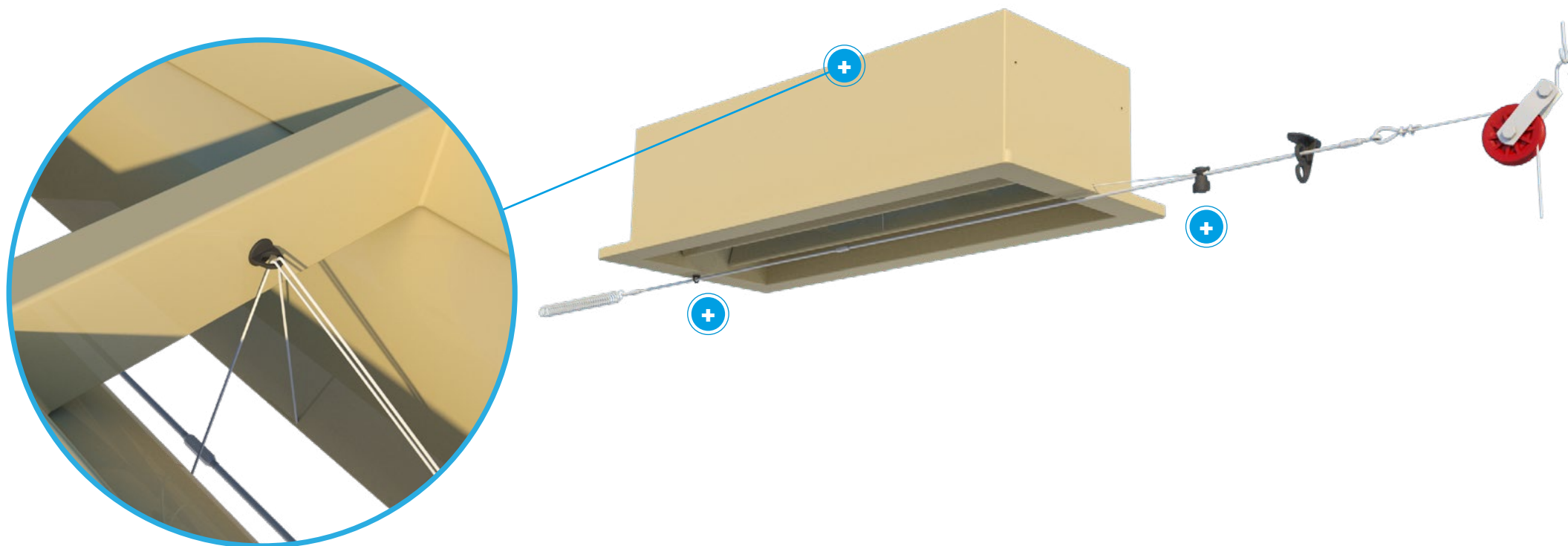

INFO

DATASHEET

ASSEMBLY

MOUNTING

WORKING

MAINTENANCE



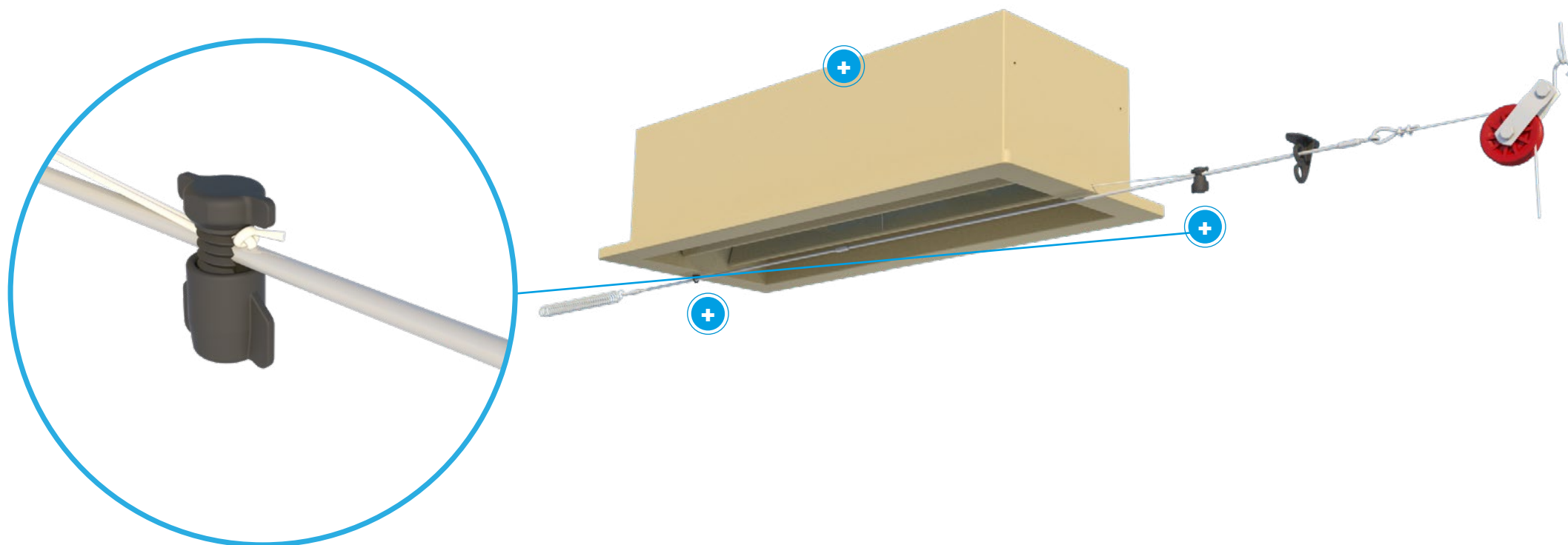

TPI-621

INFO

DATASHEET

ASSEMBLY

MOUNTING

WORKING

MAINTENANCE



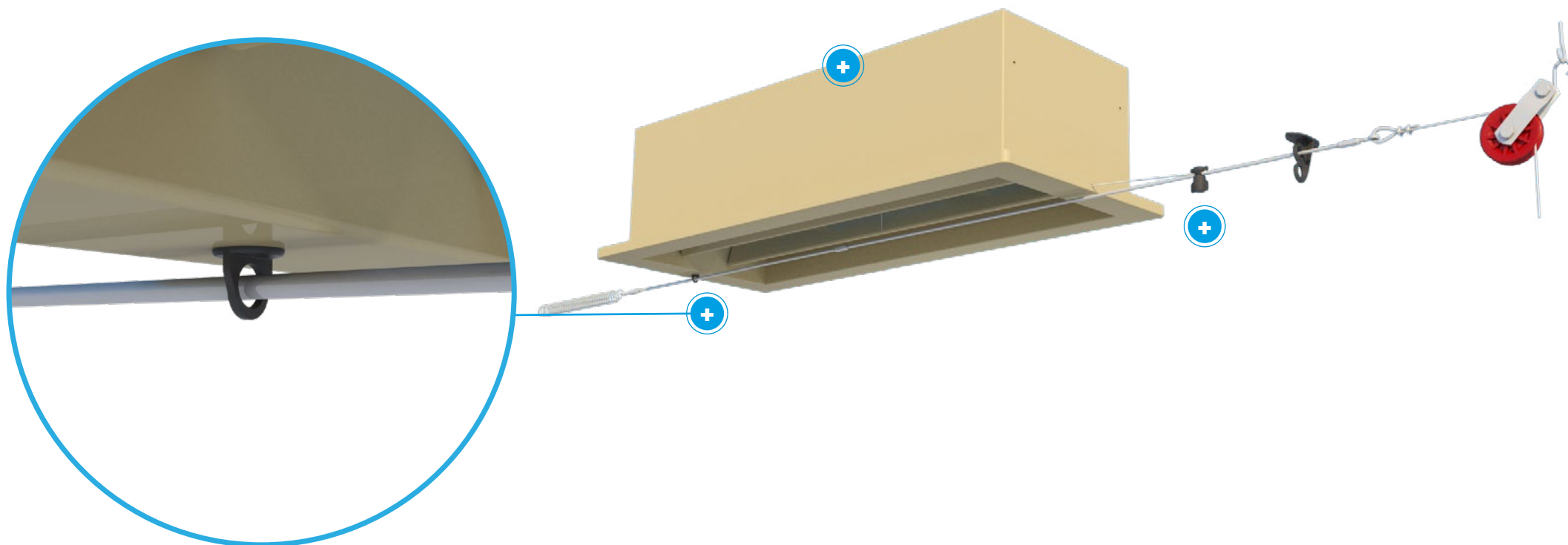

INFO

DATASHEET

ASSEMBLY

MOUNTING

WORKING

MAINTENANCE



All sizes are in cm and inches

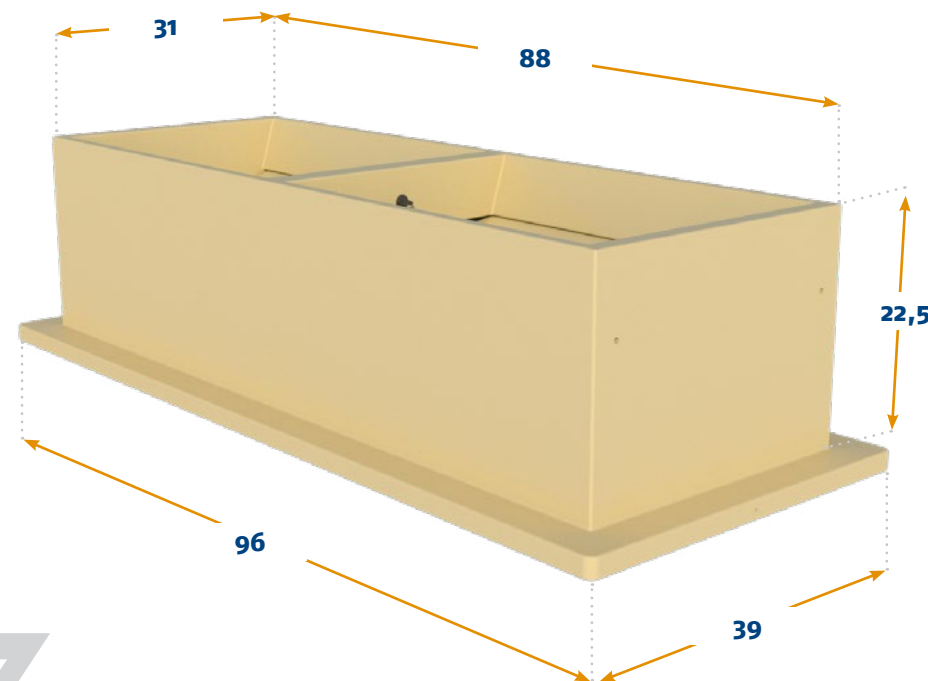
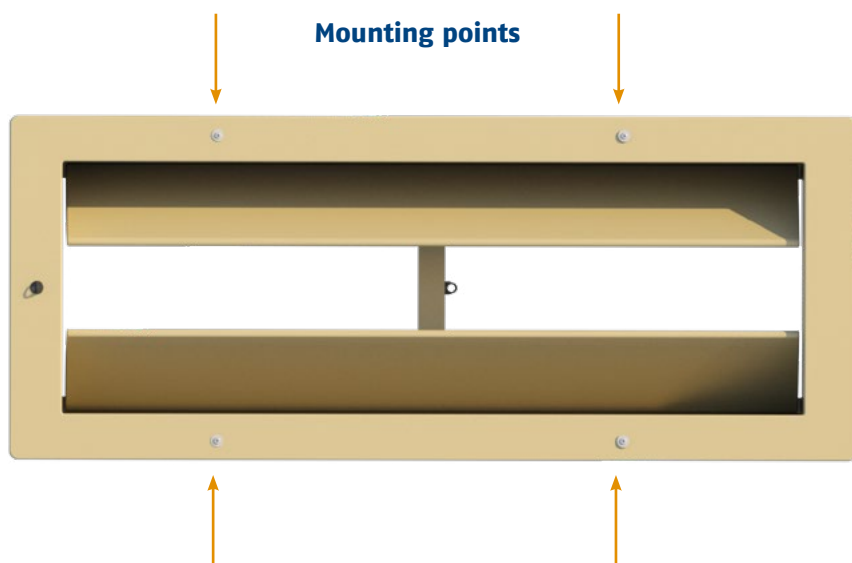

MOUNTING

Mounting type	Ceiling
Mounting hole size	90 cm / 35,43 inch x 33 cm / 12,99 inch



[INFO](#)

[DATASHEET](#)

[ASSEMBLY](#)

[MOUNTING](#)

[WORKING](#)

[MAINTENANCE](#)



AIR FLOW

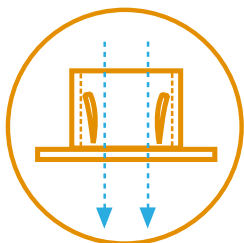
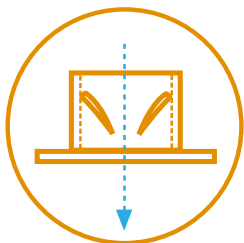

220-P Corridor ventilation

This inlet is specially developed to drop air straight down into corridors. Installing this inlet directly above the animals is not recommended because incoming air should not drop directly onto the animals.

Working with end-weights or springs

We offer two products which can be used to keep tension on the main cable. A PVC cylinder which can be filled with concrete or sand to act as end-weight, or a spring that holds tension on the cable.

Pre-heating

The advantage of ceiling inlets is that the incoming air can be pre-heated in the attic of the house before entering the area where the animals are located.

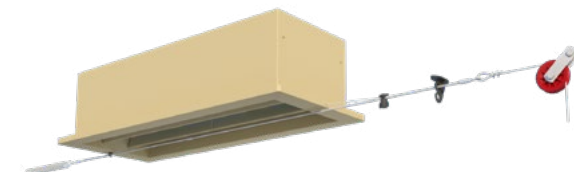
[INFO](#)[DATASHEET](#)[ASSEMBLY](#)[MOUNTING](#)[WORKING](#)[MAINTENANCE](#)

Wind hoods and Light traps

We provide custom wind hoods & light traps for wall inlets.

These traps are made of high quality polyethylene and are UV resistant.

The material is weather resistant and easy to clean and install. Simply attach the sheets with spacers between each sheet and build light traps in any size you need.

Light traps are also usable with tunnel inlets.



[INFO](#)

[DATASHEET](#)

[ASSEMBLY](#)

[MOUNTING](#)

[WORKING](#)

[MAINTENANCE](#)



LIGHT TRAPS

Model	W	H	D
TPI-933G (E) model 145	690 mm / 27.16"	310 mm / 12.20"	225 mm / 8.85"
TPI-931G (E) model 1800	575 mm / 22.64"	445 mm / 17.52"	225 mm / 8.85"
TPI-934G (E) model 3000	895 mm / 35.24"	413 mm / 16.26"	225 mm / 8.85"
TPI-932G (E) model 4000	740 mm / 29.13"	590 mm / 23.23"	225 mm / 8.85"
TPI-920 (for fan)	1000 mm / 39.37"	1000 mm / 39.37"	225 mm / 8.85"
TPI-921 (for fan)	1250 mm / 49.21"	1250 mm / 49.21"	225 mm / 8.85"
TPI-922 (for fan)	1400 mm / 55.12"	1400 mm / 55.12"	225 mm / 8.85"
TPI-924 (6000 VFG)	1500 mm / 59.06"	400 mm / 15.75"	225 mm / 8.85"
TPI-925 (6000 VFG-2)	1500 mm / 59.06"	1000 mm / 39.37"	225 mm / 8.85"
TPI-926 (6000 VFG-3)	1500 mm / 59.06"	1250 mm / 49.21"	225 mm / 8.85"
TPI-923 (6000 VFG-4)	1500 mm / 59.06"	1600 mm / 62.99"	225 mm / 8.85"

Extended flange available = D+100 mm

WIND HOODS

Model	W	H	D	SUSPENSION BRACKETS	LIGHT TRAP
TPI-950 (145/135 serie)	844 mm / 33.23"	631 mm / 24.84"	257 mm / 10.12"	TPI-901	TPI-917-TR
TPI-951 (3000/2800 serie)	1100 mm / 43.31"	733 mm / 28.86"	368 mm / 14.49"	TPI-902	TPI-918-TR
TPI-952 (4000 series/Omniflux)	976 mm / 38.43"	939 mm / 36.97"	618 mm / 24.33"	TPI-903	TPI-919-TR
TPI-954 (1800 serie)	815 mm / 32.09"	770 mm / 30.31"	418 mm / 16.46"	TPI-904	TPI-916-TR
TPI-955 (Ventum/Aeron)	1366 mm / 53.78"	860 mm / 33.86"	358 mm / 14.09"	TPI-905	TPI-915-TR

	WH 145 (mm/in)	WH 1800 (mm/in)	WH 3000 (mm/in)	WH 4000 (mm/in)	WH Ventum
A	280/11,02	705/27,76	385/15,16	575/22,64	350/13,78
B	660/25,98	645/25,39	870/34,25	725/28,54	1140/44,88
C	814/32,05	795/31,3	1080/42,52	945/37,20	1336/52,6
D	20/0,79	-	20/0,79	20/0,79	20/0,79
E	173/6,81	47/1,85	206/8,11	206/8,11	127,5/5,02
F	346/13,62	253/9,96	412/16,22	412/16,22	317,5/12,5
G	539/21,22	459/18,07	638 / 25,12	618/24,33	507,5/19,98
H	-	685/26,97	-	844/33,23	697,5/27,46
I	-	-	-	-	835,5/32,89

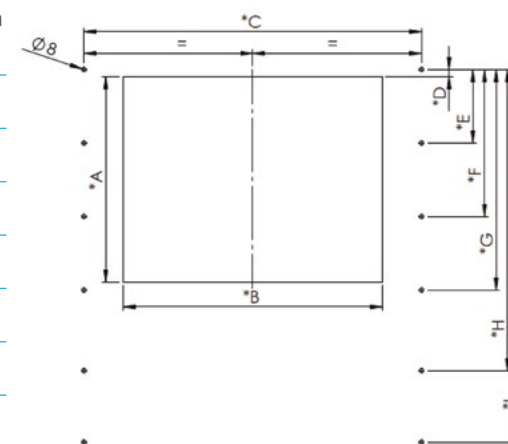

INFO

DATASHEET

ASSEMBLY

MOUNTING

WORKING

MAINTENANCE



Wind hoods and Light traps

ASSEMBLY

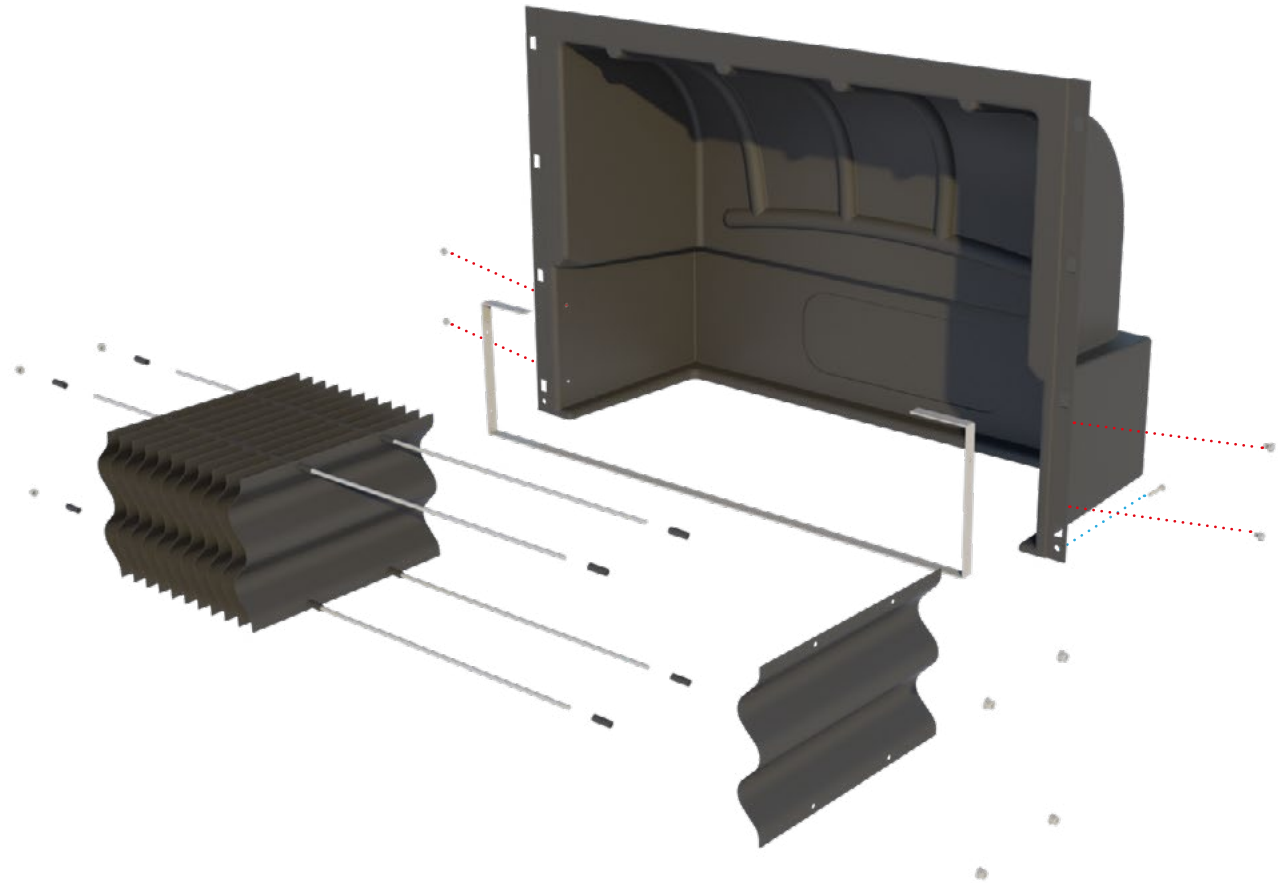
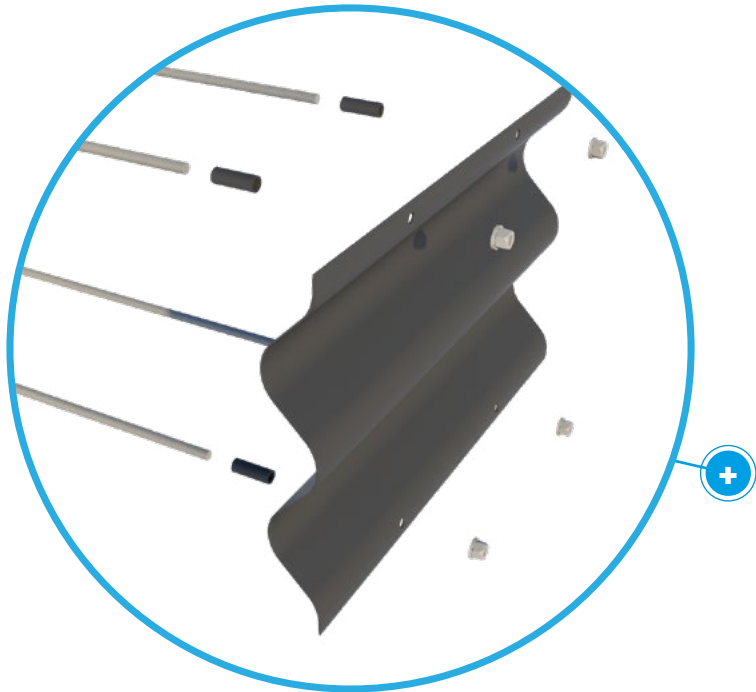

 **WIND HOOD**

 **LIGHT TRAP**

INFO

DATASHEET

ASSEMBLY

MOUNTING

WORKING

MAINTENANCE



Wind hoods and Light traps

ASSEMBLY

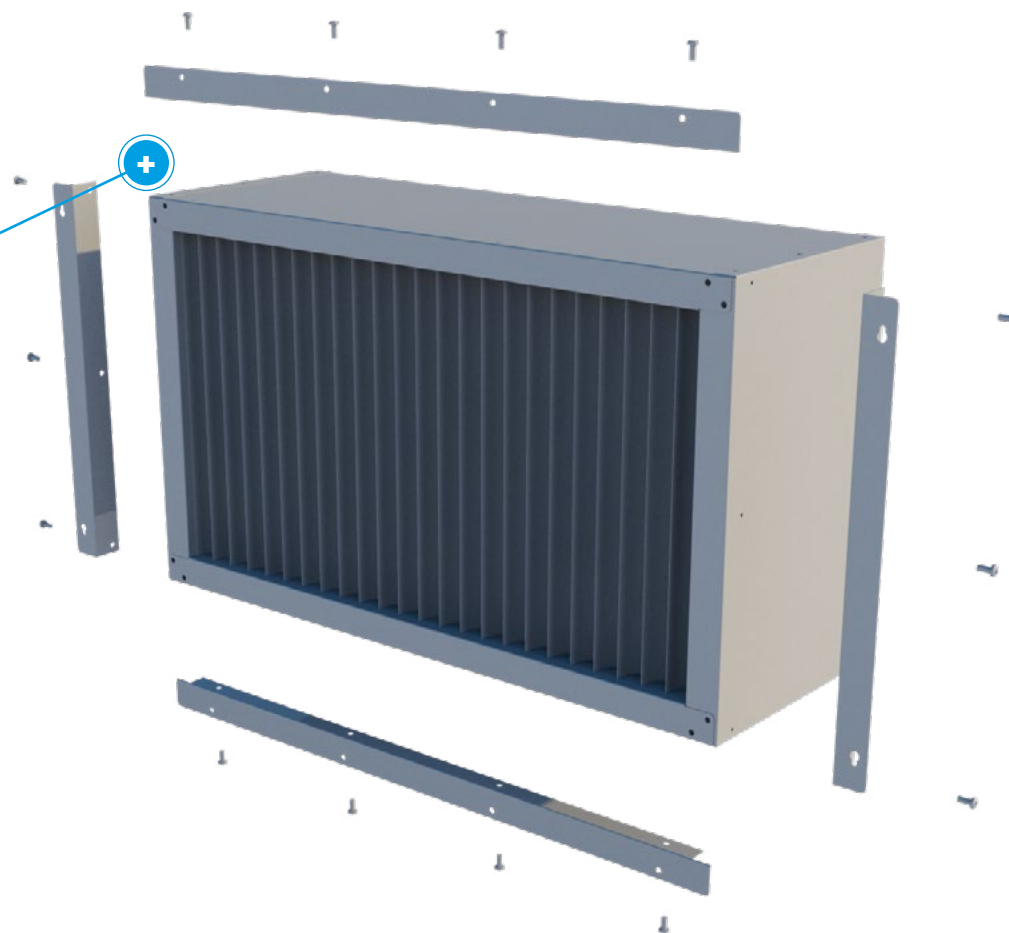
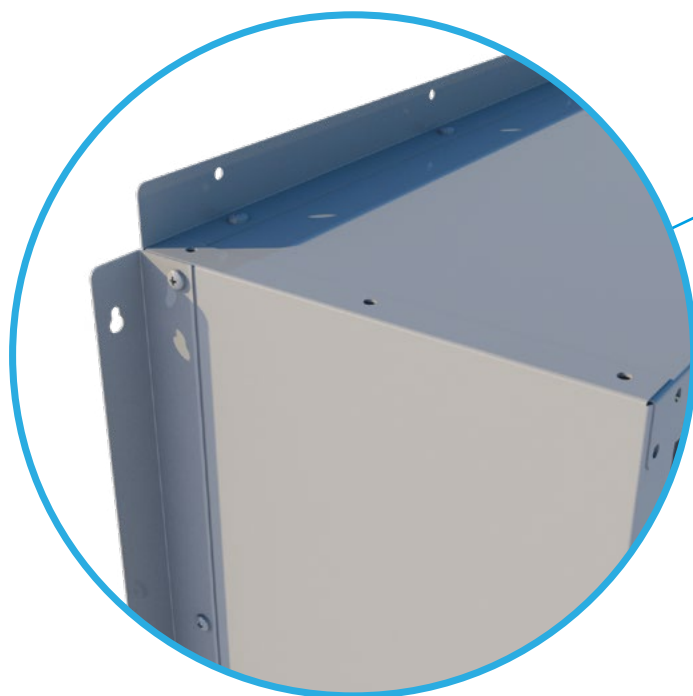

 WIND HOOD

 LIGHT TRAP

INFO

DATASHEET

ASSEMBLY

MOUNTING

WORKING

MAINTENANCE



Wind hoods and Light traps

MOUNTING

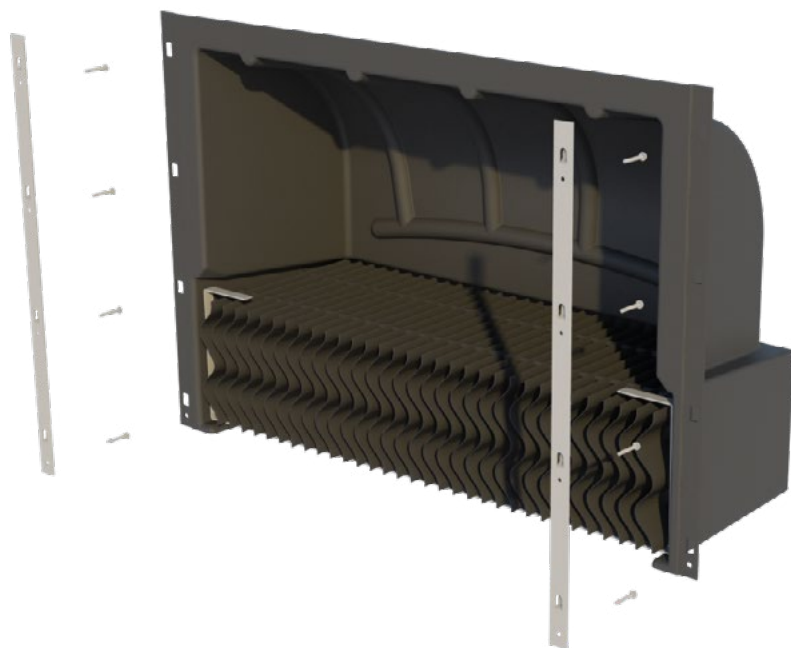

The wind hood is kept in place by two screws in the bottom of the suspension brackets. These screws are fastened after the wind hood is suspended from the brackets.

[INFO](#)

[DATASHEET](#)

[ASSEMBLY](#)

[MOUNTING](#)

[WORKING](#)

[MAINTENANCE](#)



Air guides

Air guides are available for almost all inlets in our program. Our light weight air guides are produced out of black PVC. Assembly in combination with our centrally controlled inlets is very easy. Simply attach the flaps onto the central pulley. Then attach the side mounts and screw these onto the flange of the inlet. After that adjust the flaps to the desired position and you're good to go. For inlets with side arms, attach the two mounts to the flap and mount them onto the flange of the inlet.

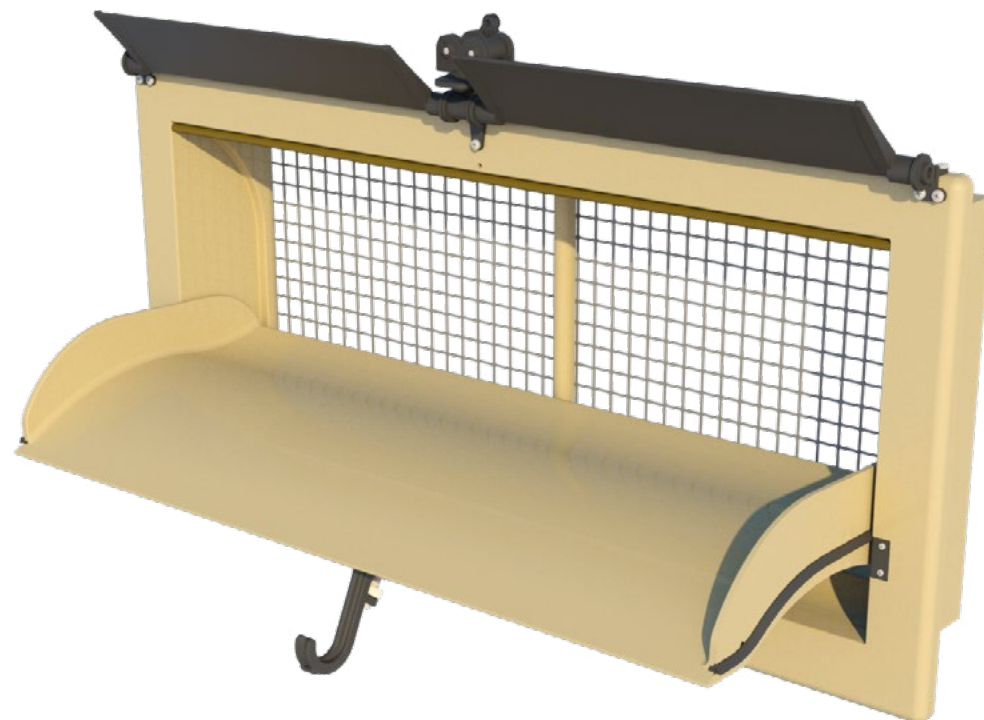
[INFO](#)[DATASHEET](#)[ASSEMBLY](#)[MOUNTING](#)[WORKING](#)[MAINTENANCE](#)



Air guides DATASHEET



AIR GUIDES

Model

TPI-790	Air Guide 135/145 Series	PVC
TPI-790-C	Air Guide 135/145-C Series	PVC
TPI-791-C	Air Guide 1800-C Series	PVC
TPI-792	Air Guide 2800 Series	PVC
TPI-793-C	Air Guide 3000-C Series	PVC

Model

TPI-794-C	Air Guide 4000-C Series	PVC
TPI-796	Air Guide 6000 Series	PVC
TPI-796-C	Air Guide 6000-C Series	PVC
TPI-797	Air Guide Ventum Series	PVC

INFO

DATASHEET

ASSEMBLY

MOUNTING

WORKING

MAINTENANCE



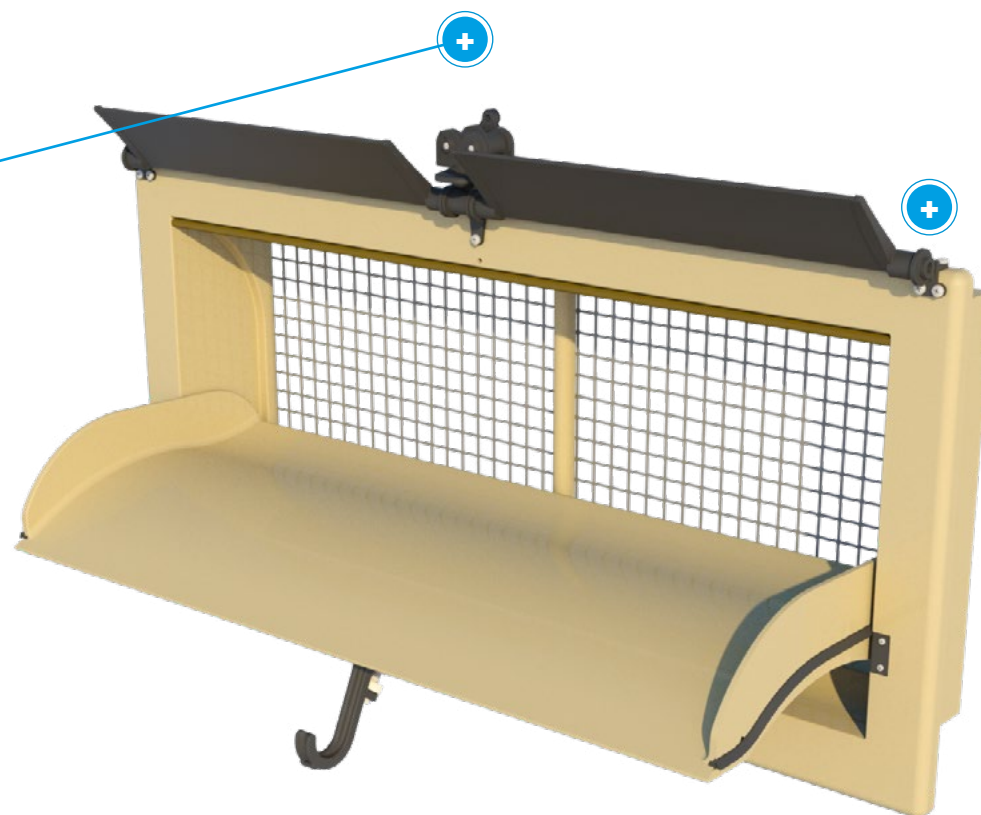
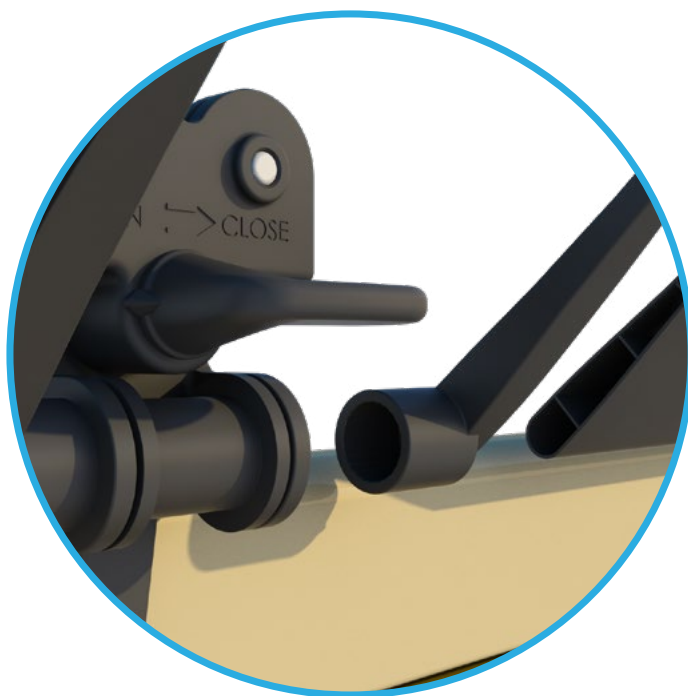

INFO

DATASHEET

ASSEMBLY

MOUNTING

WORKING

MAINTENANCE



Air guides ASSEMBLY

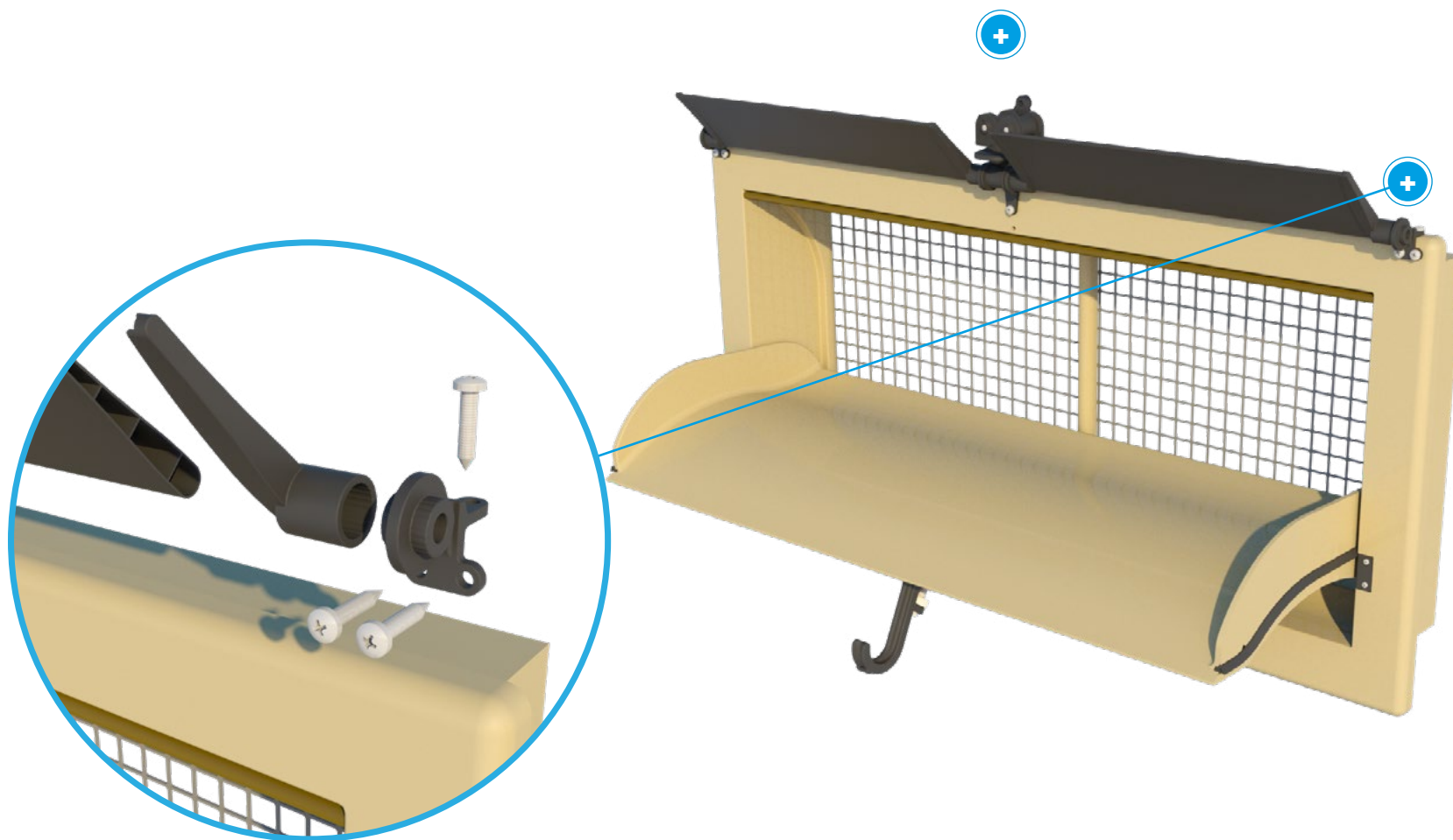

INFO

DATASHEET

ASSEMBLY

MOUNTING

WORKING

MAINTENANCE



Main Cable Self Opening & Self Closing

When planning the position of the inlets it is important to also think of where the main cable is going to be. The main cable is used to open and close all inlets connected to it. There are a few things to mention concerning the set-up of the main cable. First, the importance of a clear path for the cable to run along when moving. TPI-Polytechniek offers plastic wall supports (TPI-519) to help mount the cable onto the wall of the house. We recommend to use a wall support every 1.5m to make sure the main cable does not bend or curve too much. Second, we advise to place the motor winch or actuator in the middle of the house so two equally large groups of inlets are created. This ensures a good division of forces exerted on the cable, inlets and the motor winch or actuator. This also goes for tunnel units being installed in the gable wall. Third, to go around corners or over doors we offer a wide variety of accessories like Pulley Units, flexible steel cable and so on, ask your sales manager for advice if needed.

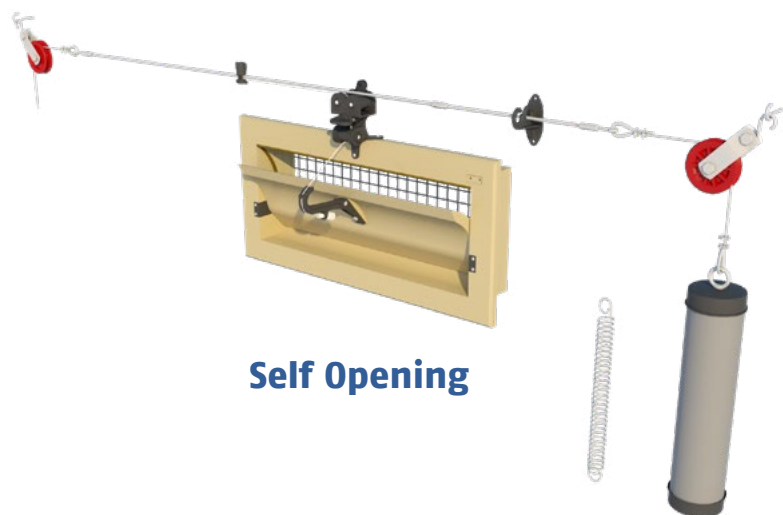

Self Opening

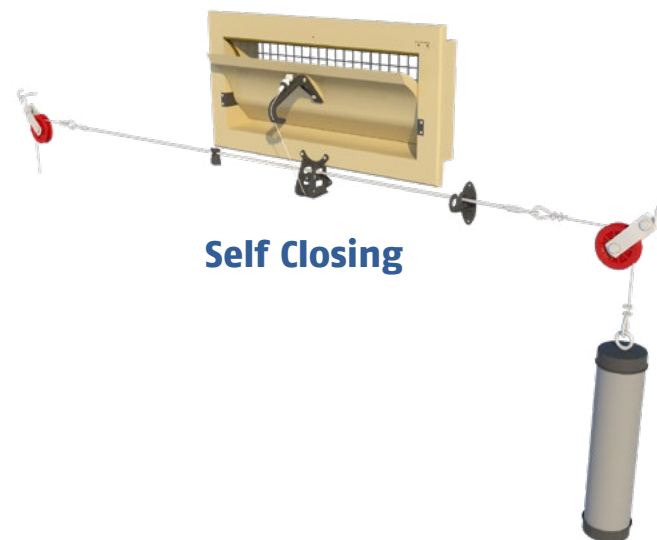

Self Closing

INFO

ACCESSORIES

ASSEMBLY

MOUNTING

MAINTENANCE





Main Cable DATASHEET



INFORMATION

Item number	Description	Weight/per Rod	Length
TPI-513	Galvanized wire	25 kg / 55 lb	+/- 160m /525ft
TPI-514 - 2	Solid stainless steel rod	0,23 kg / 0,5 lb	2 M / 6,5 ft
TPI-514 - 3	Solid stainless steel rod	0,36 kg / 0,8 lb	3 M / 9,8 ft
TPI-630	300 mm = 1,18" – 900 mm = 3,5" stretch, tension 40 N		
TPI-616	PVC and Weight Container		

OPTIONAL ACCESSORIES

TPI-411	S-hook with pulley, steel (90 mm = 3,5")
TPI-412	S-hook with pulley, nylon (90 mm = 3,5")
TPI-413	Single, front mounted pulley
TPI-418 KI90	Double, side mounted pulley, steel (90 mm = 3,5")
TPI-418 KN90	Double, side mounted pulley, nylon (90 mm = 3,5")
TPI-512	Plasticized cable (10 / 60 / 80 / 100 meter) (33 / 197 / 262,5 / 328 feet)
TPI-515	Stainless steel cable 3 mm = 0,12" (roll 10 meter)
TPI-519	Main Cable Support
TPI-616	PVC and Weight Container
TPI-617	Eye bolt for solid rod (M5)
TPI-618	Connection nut (M5)
TPI-620	Cable clamp SS u-form (for cable 5 mm)
TPI-627	Cable protector (5 mm)
TPI-630	Galvanized spring

INFO

ACCESSORIES

ASSEMBLY

MOUNTING

MAINTENANCE



Main Cable ASSEMBLY

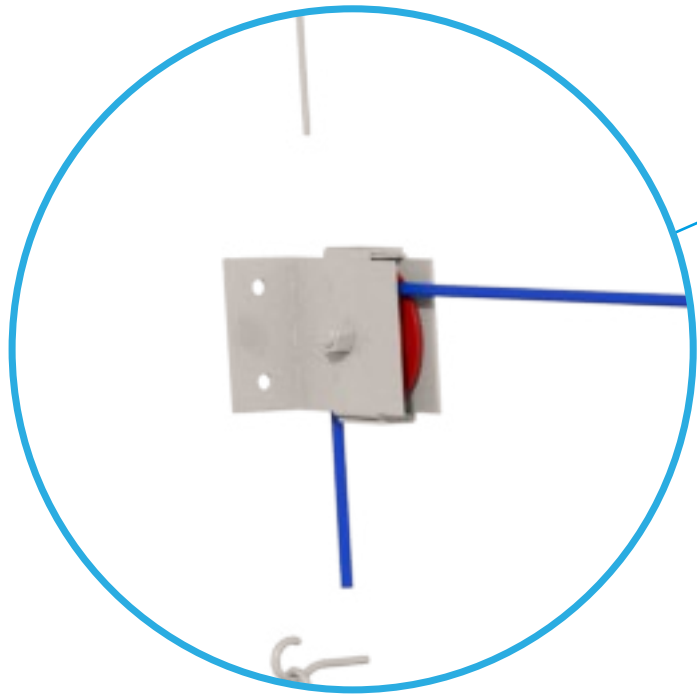

TPI-413

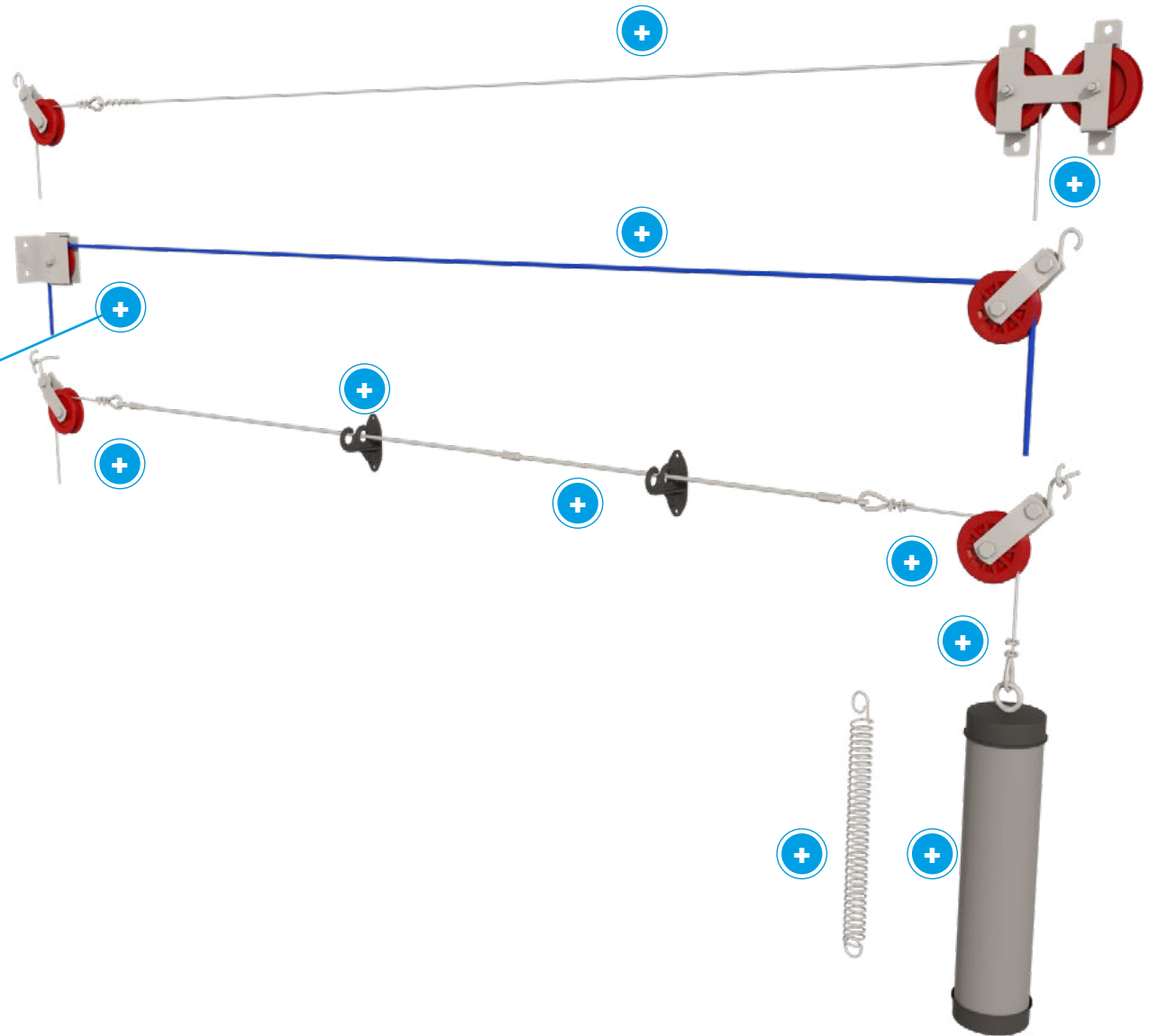

Main Cable ASSEMBLY



TPI-411

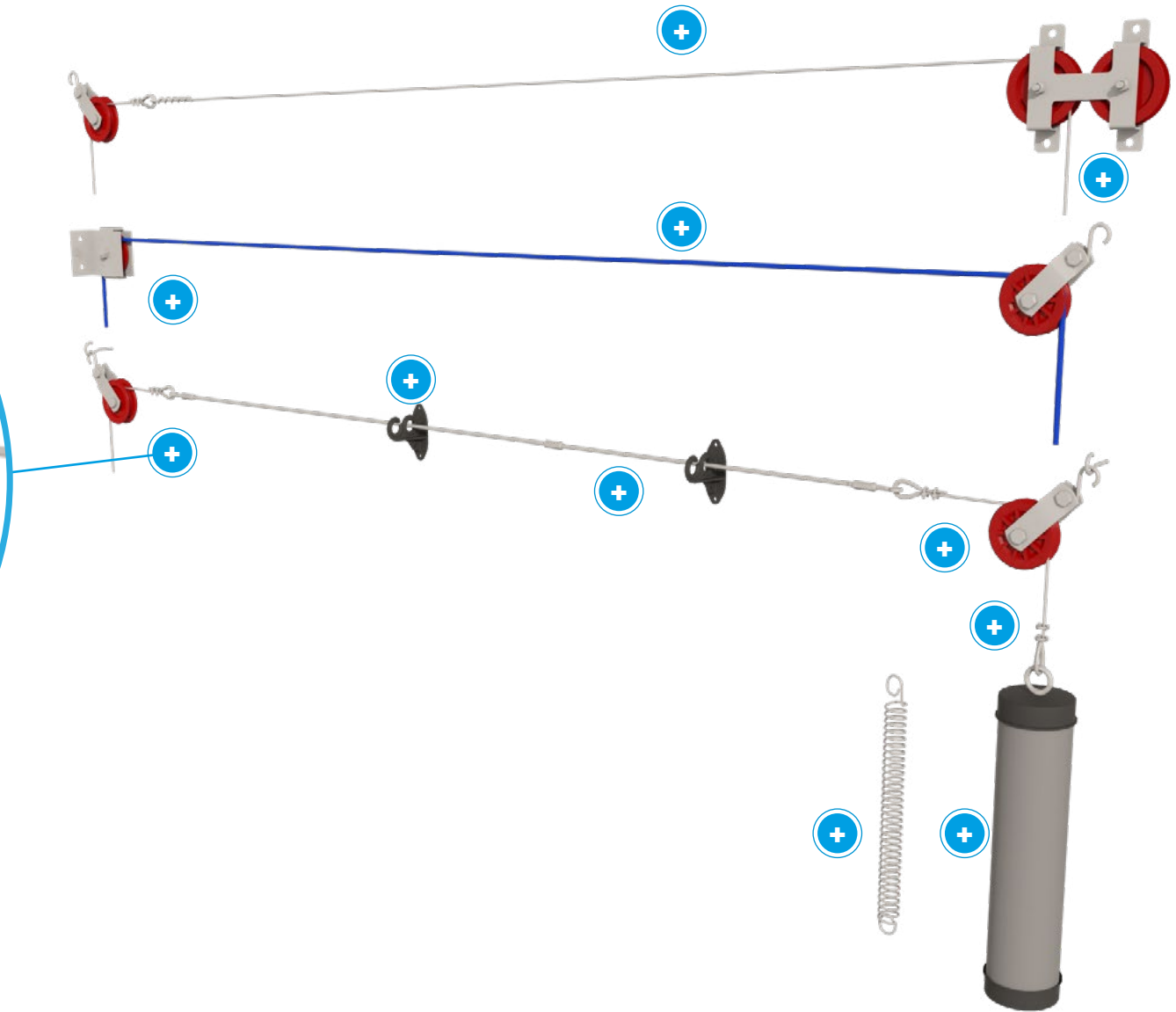



Main Cable ASSEMBLY

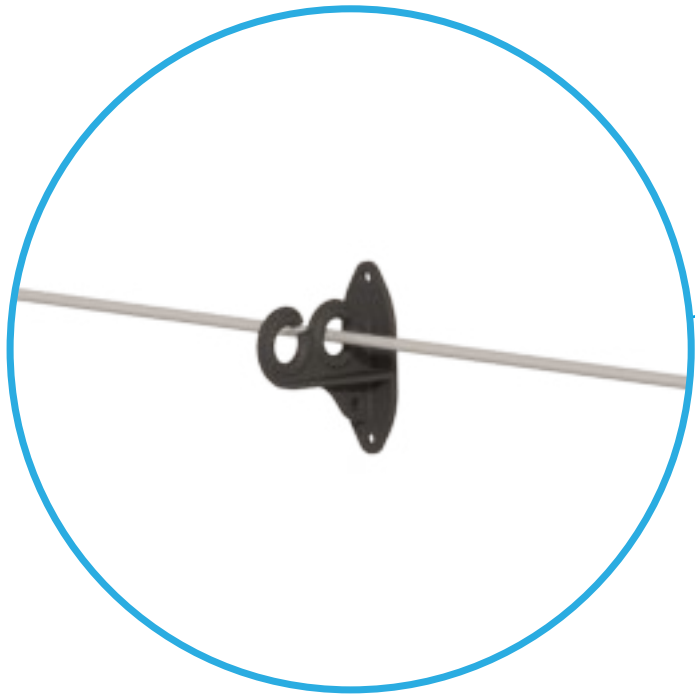

TPI-519

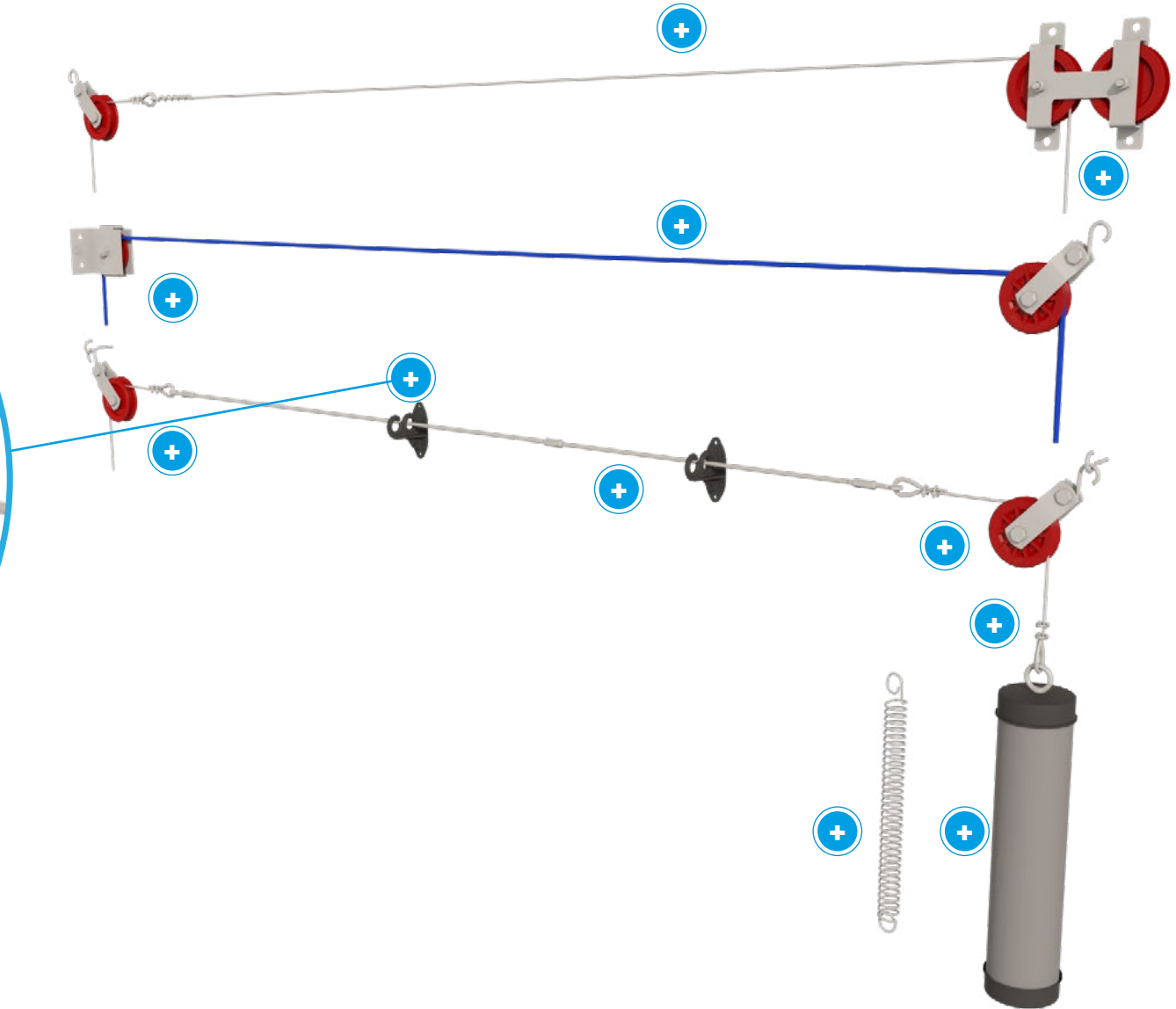

INFO

ACCESSORIES

ASSEMBLY

MOUNTING

MAINTENANCE





Main Cable ASSEMBLY

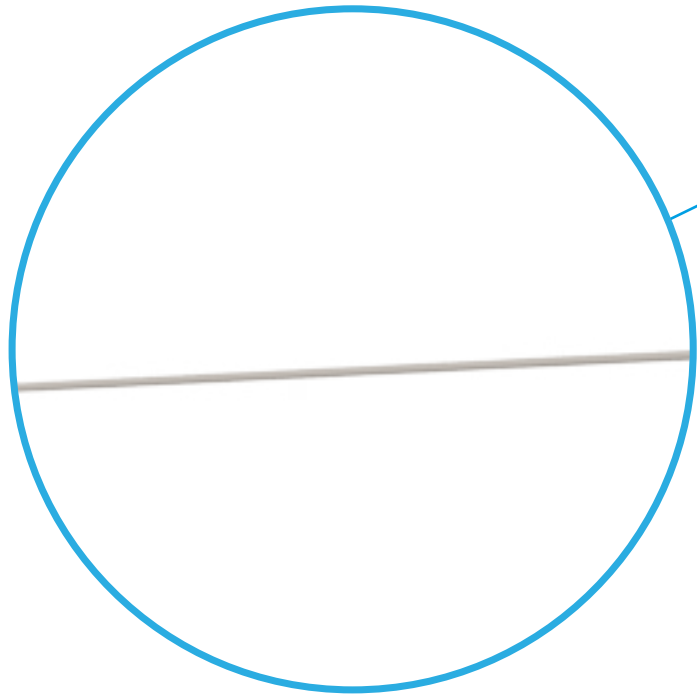

TPI-513

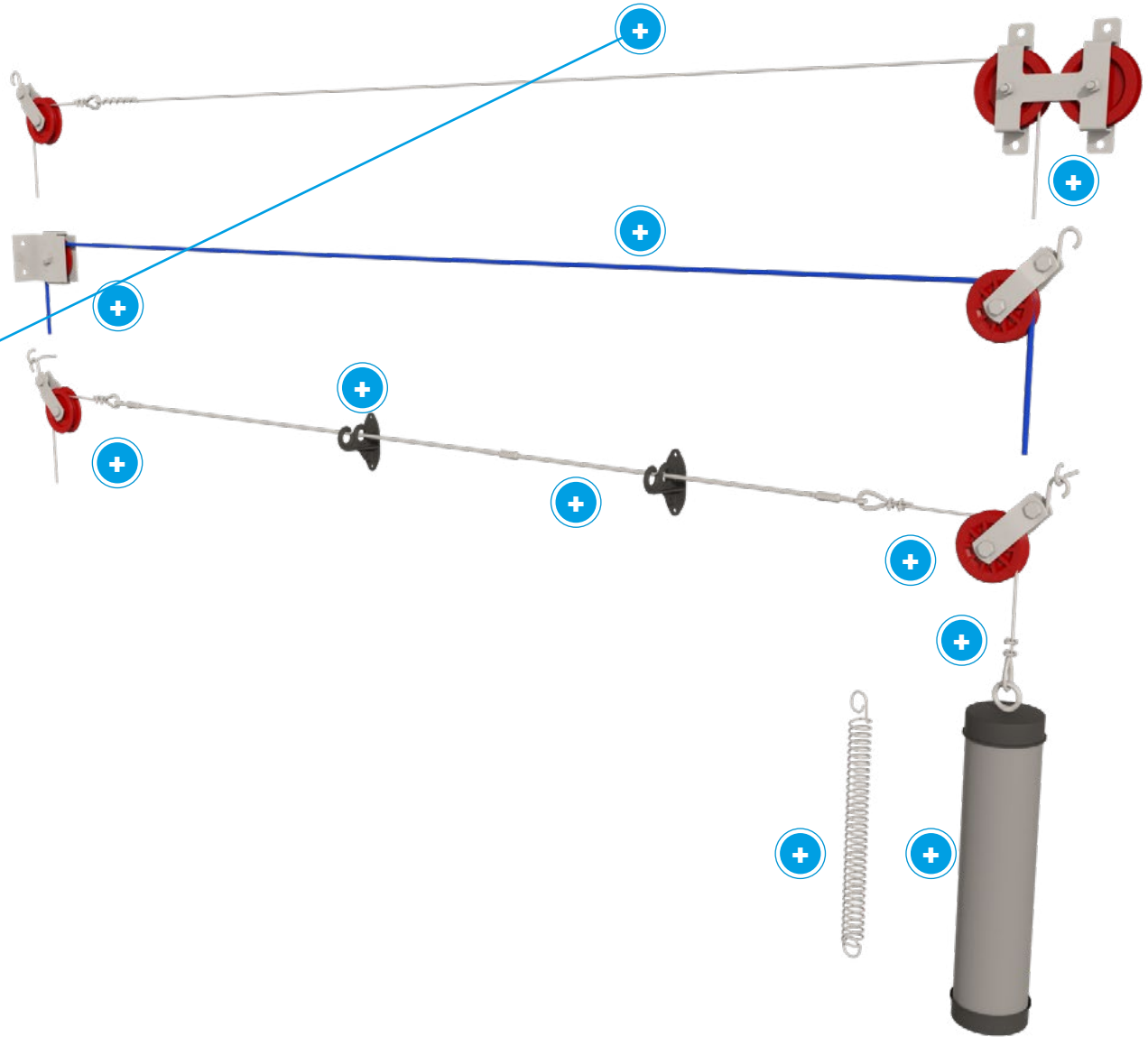

INFO

ACCESSORIES

ASSEMBLY

MOUNTING

MAINTENANCE



Main Cable ASSEMBLY

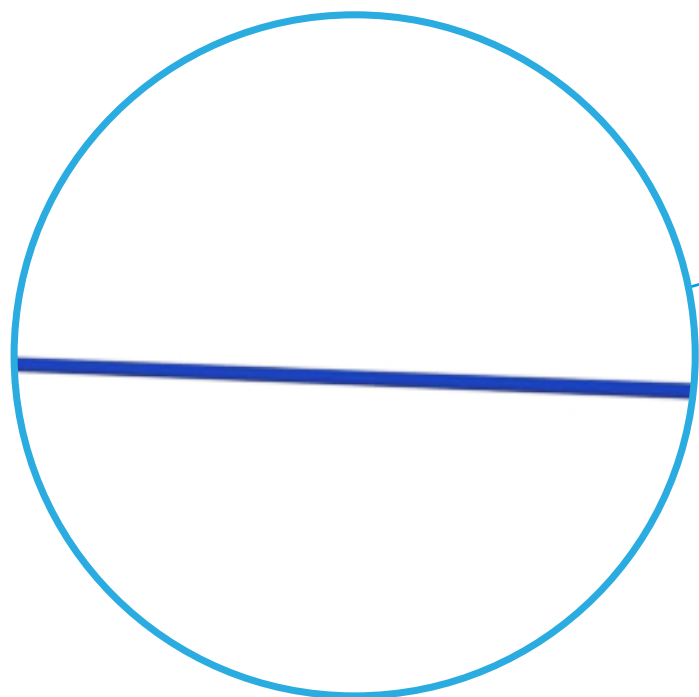

TPI-512

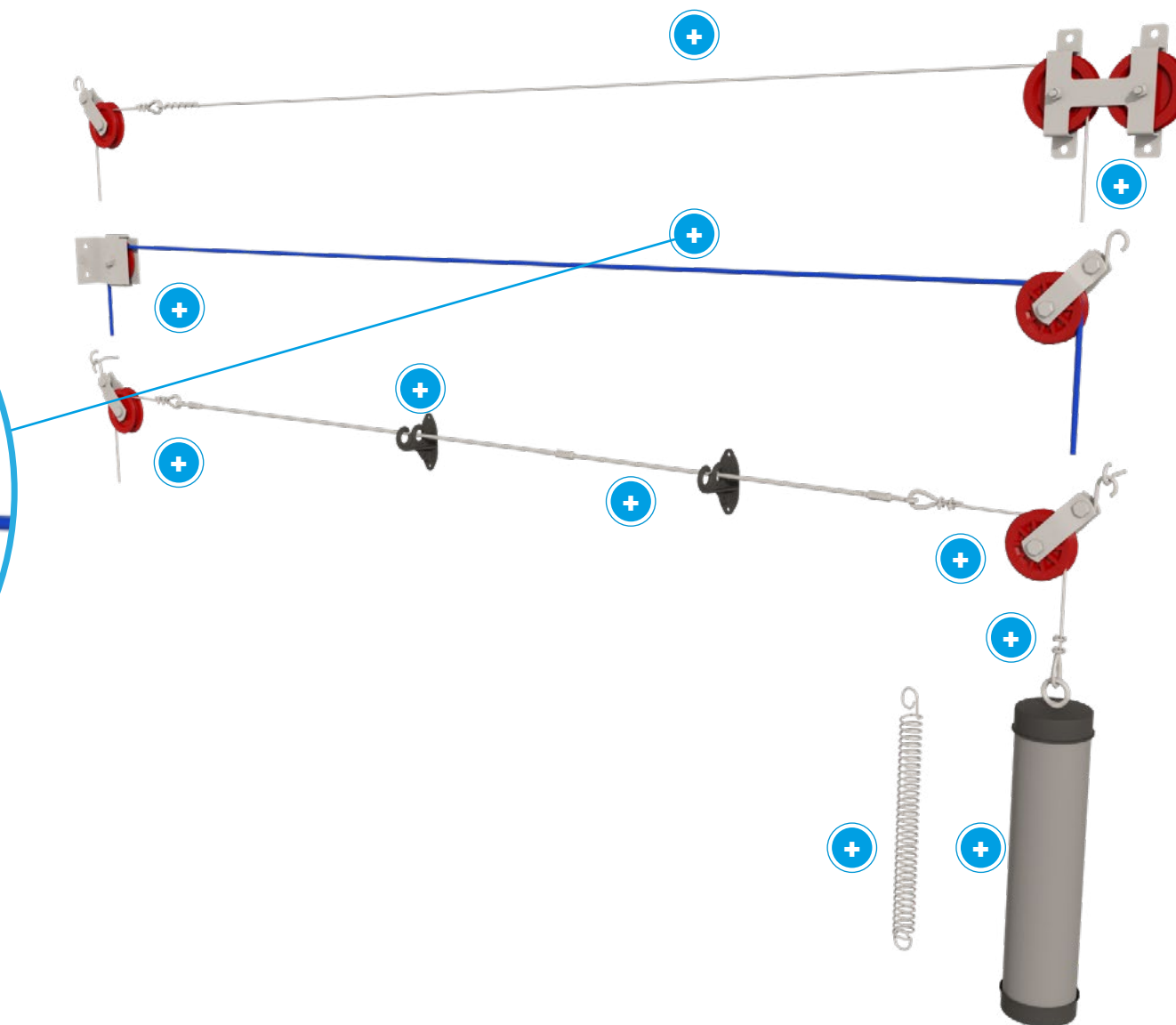

INFO

DATASHEET

ASSEMBLY

MOUNTING

MAINTENANCE



Main Cable ASSEMBLY



TPI-514-2 / TPI-514-3

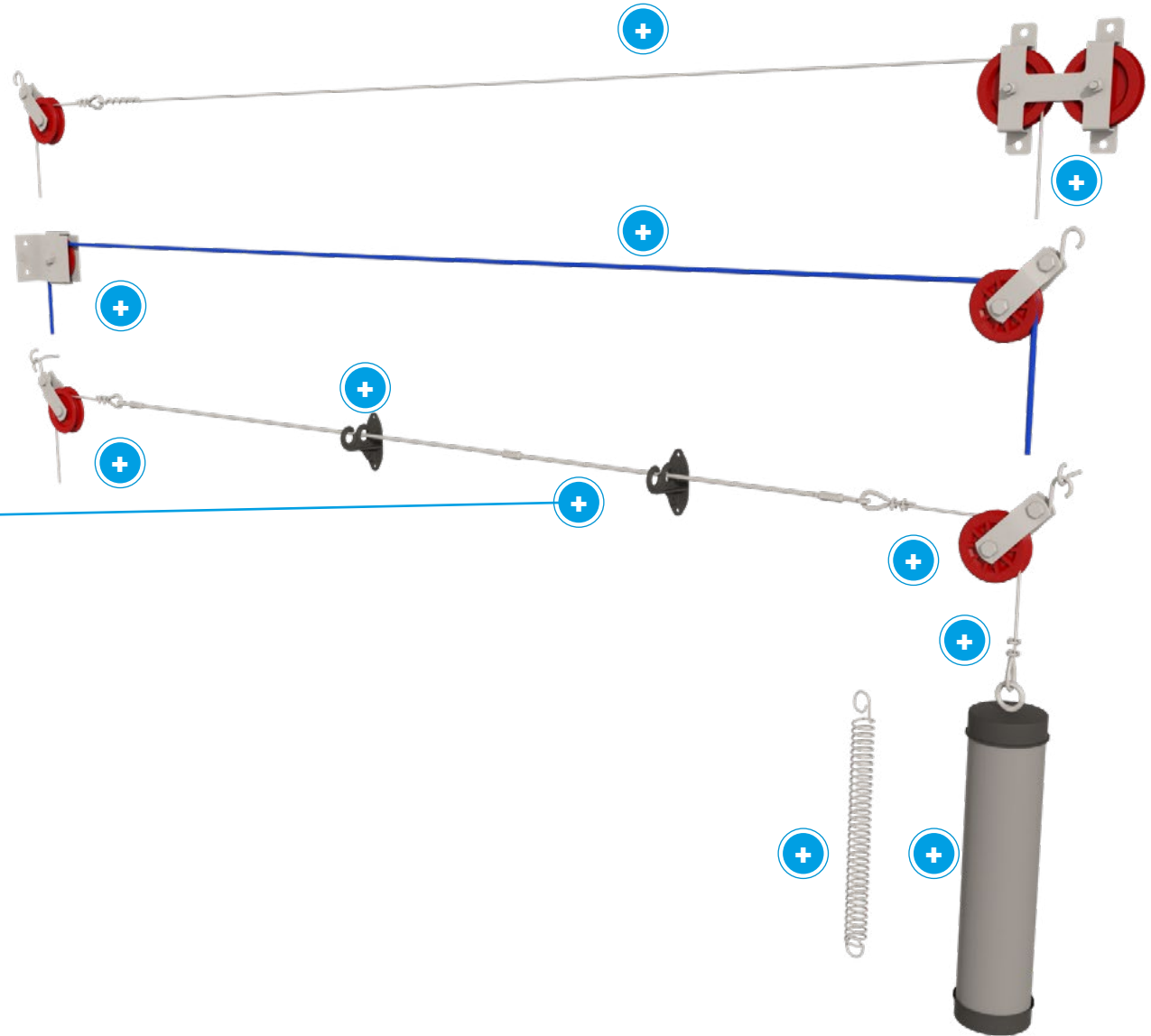

INFO

ACCESSORIES

ASSEMBLY

MOUNTING

MAINTENANCE





Main Cable ASSEMBLY

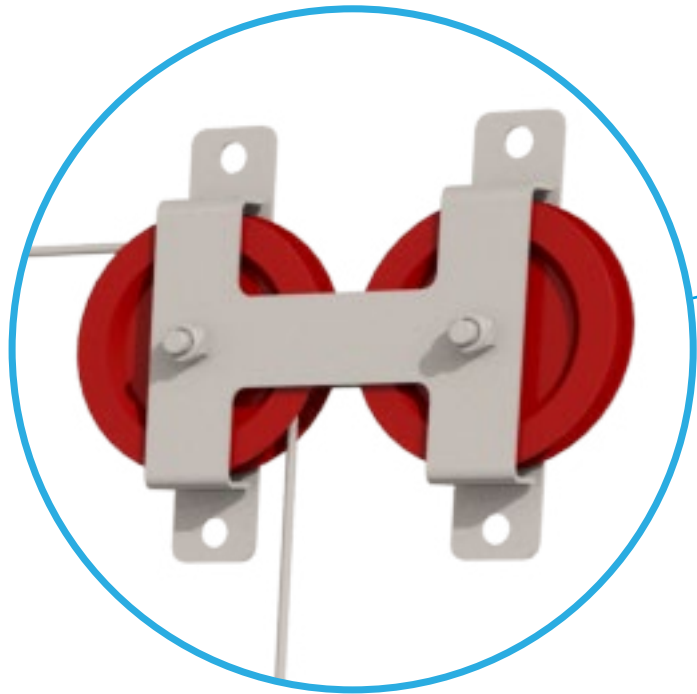

TPI-418

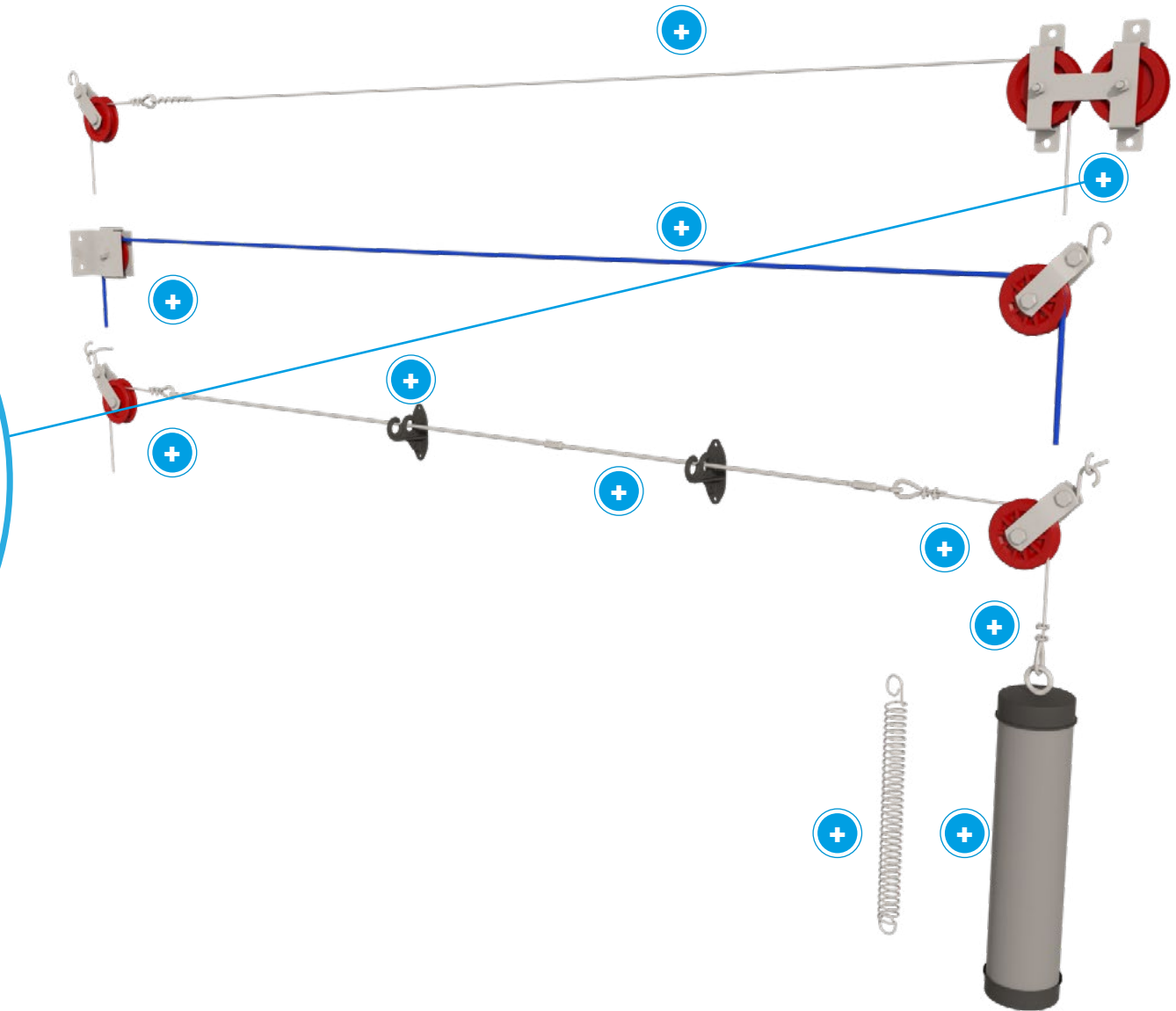

INFO

ACCESSORIES

ASSEMBLY

MOUNTING

MAINTENANCE



Main Cable ASSEMBLY

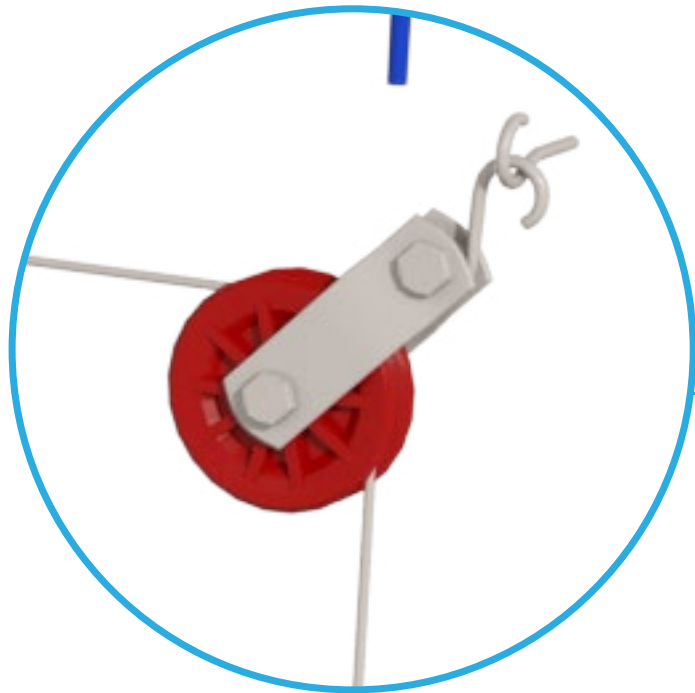

TPI-412

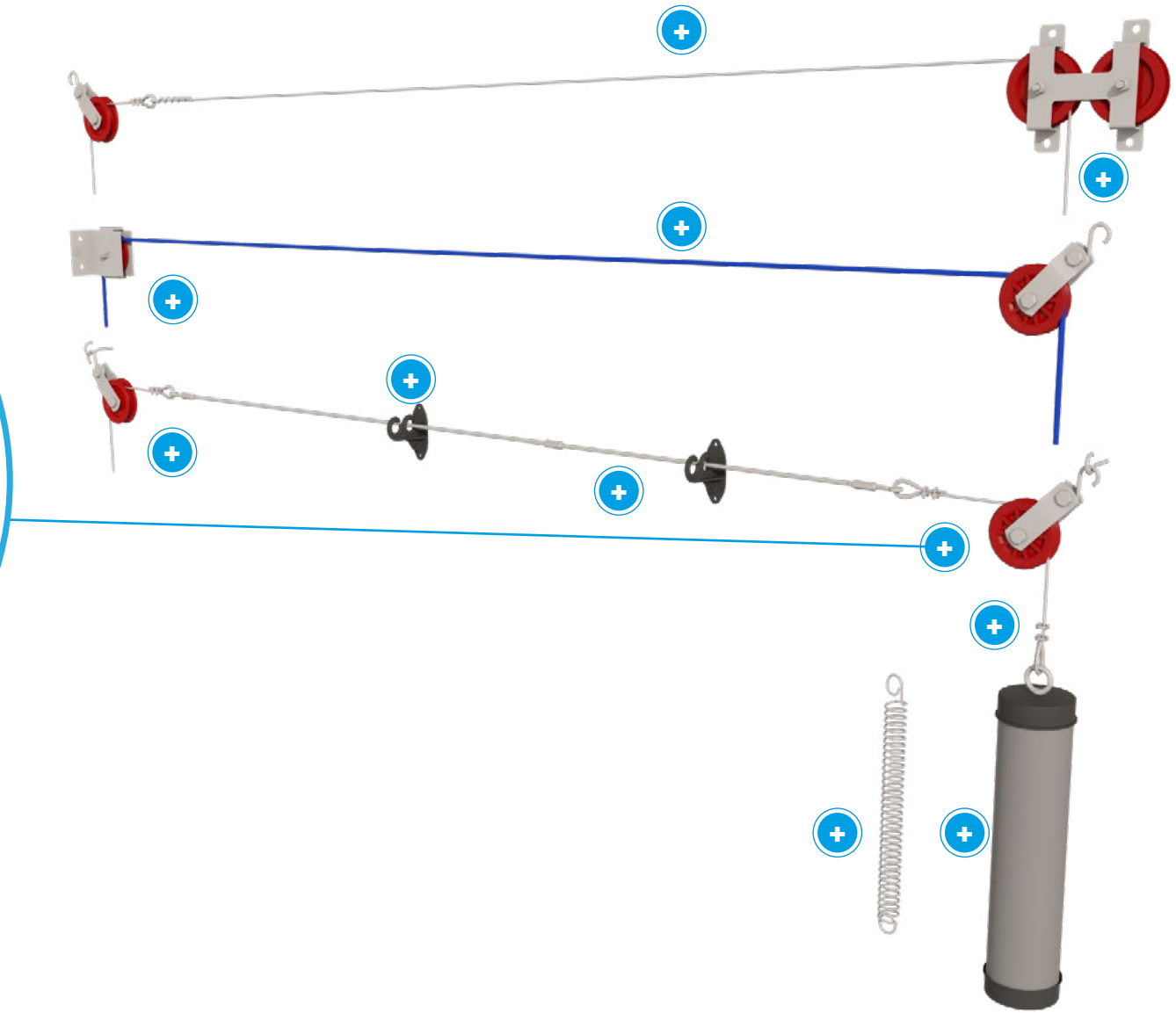

Main Cable ASSEMBLY



TPI-515

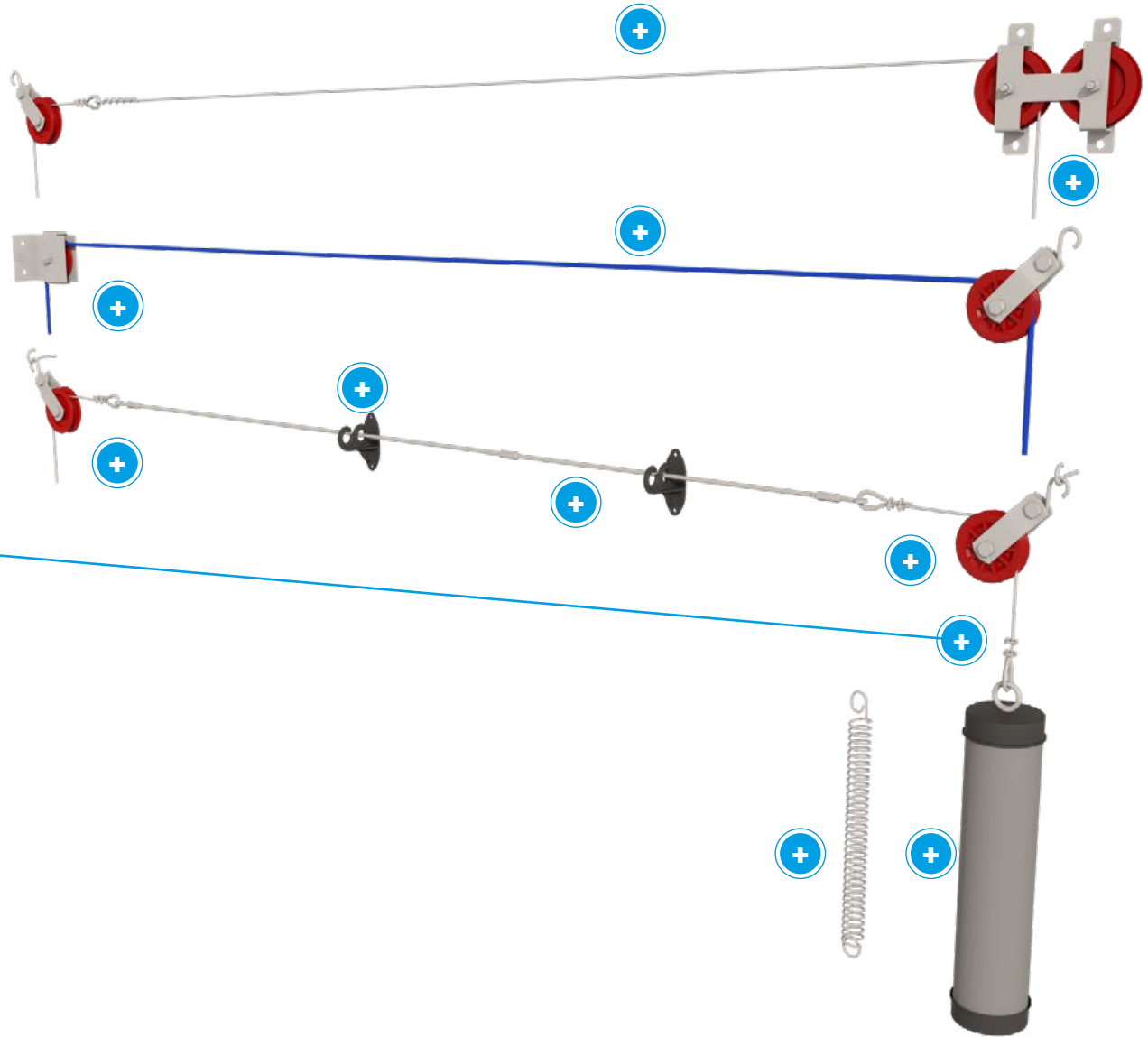

Main Cable ASSEMBLY

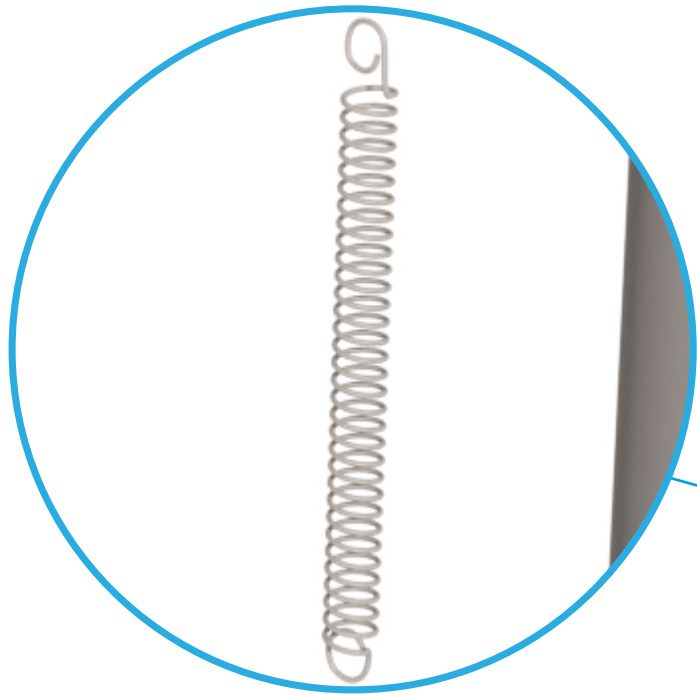

TPI-630

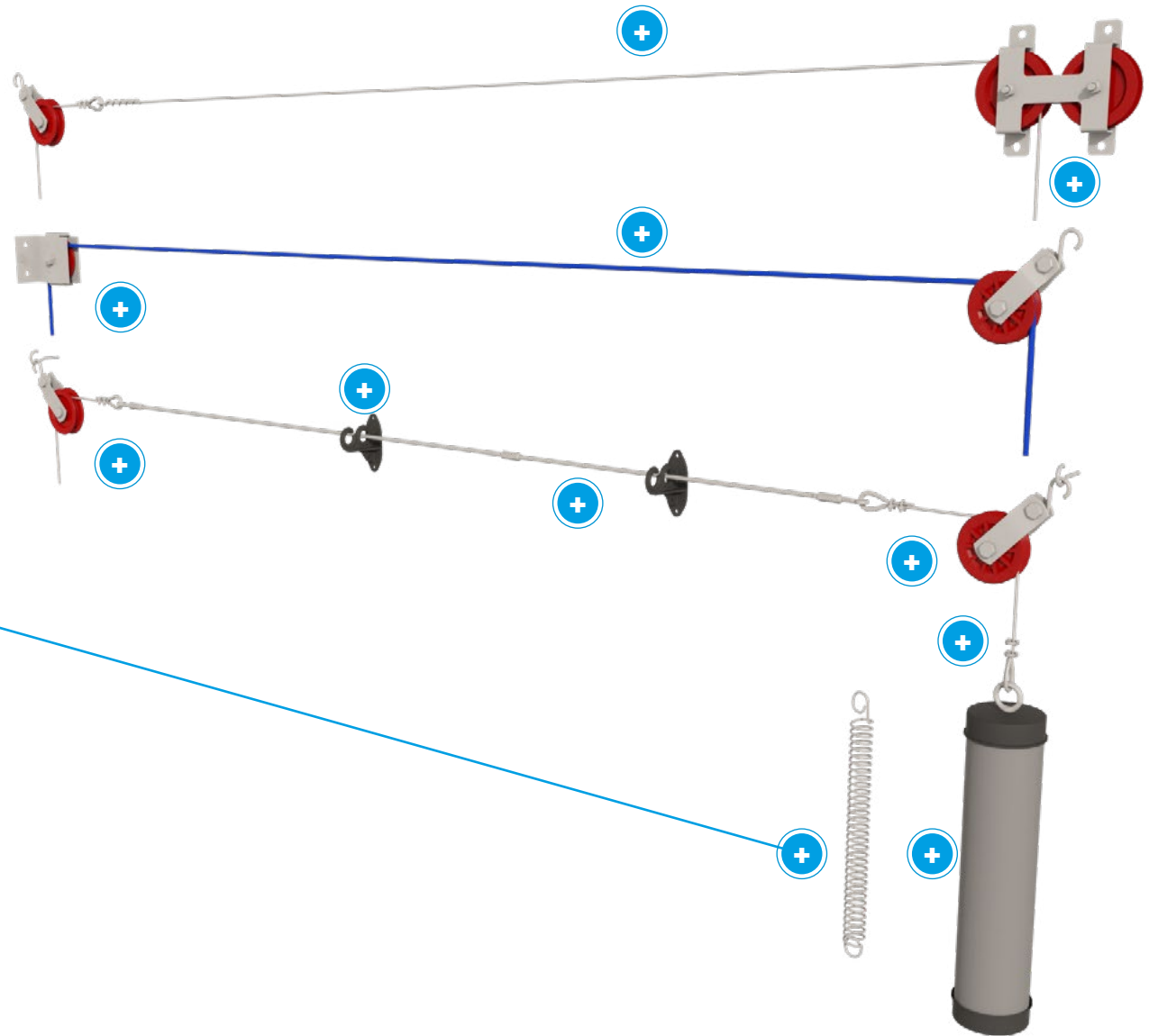

Main Cable ASSEMBLY

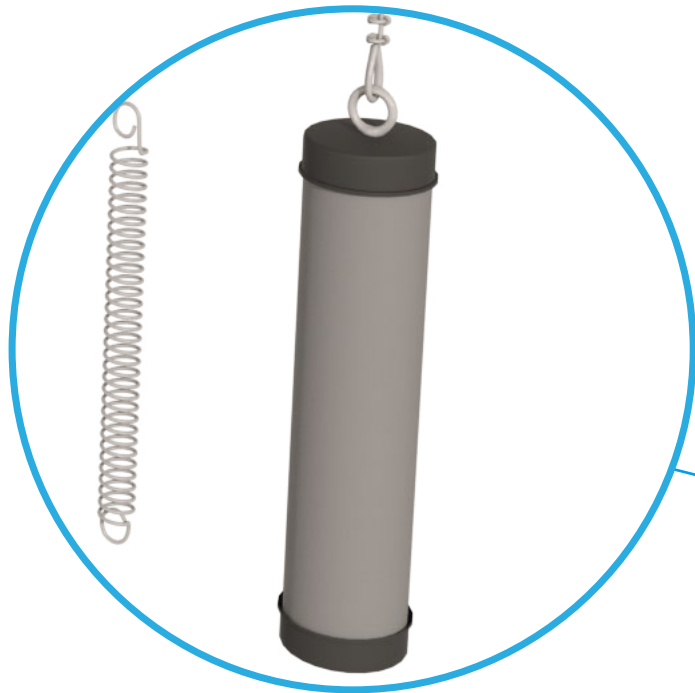

TPI-616

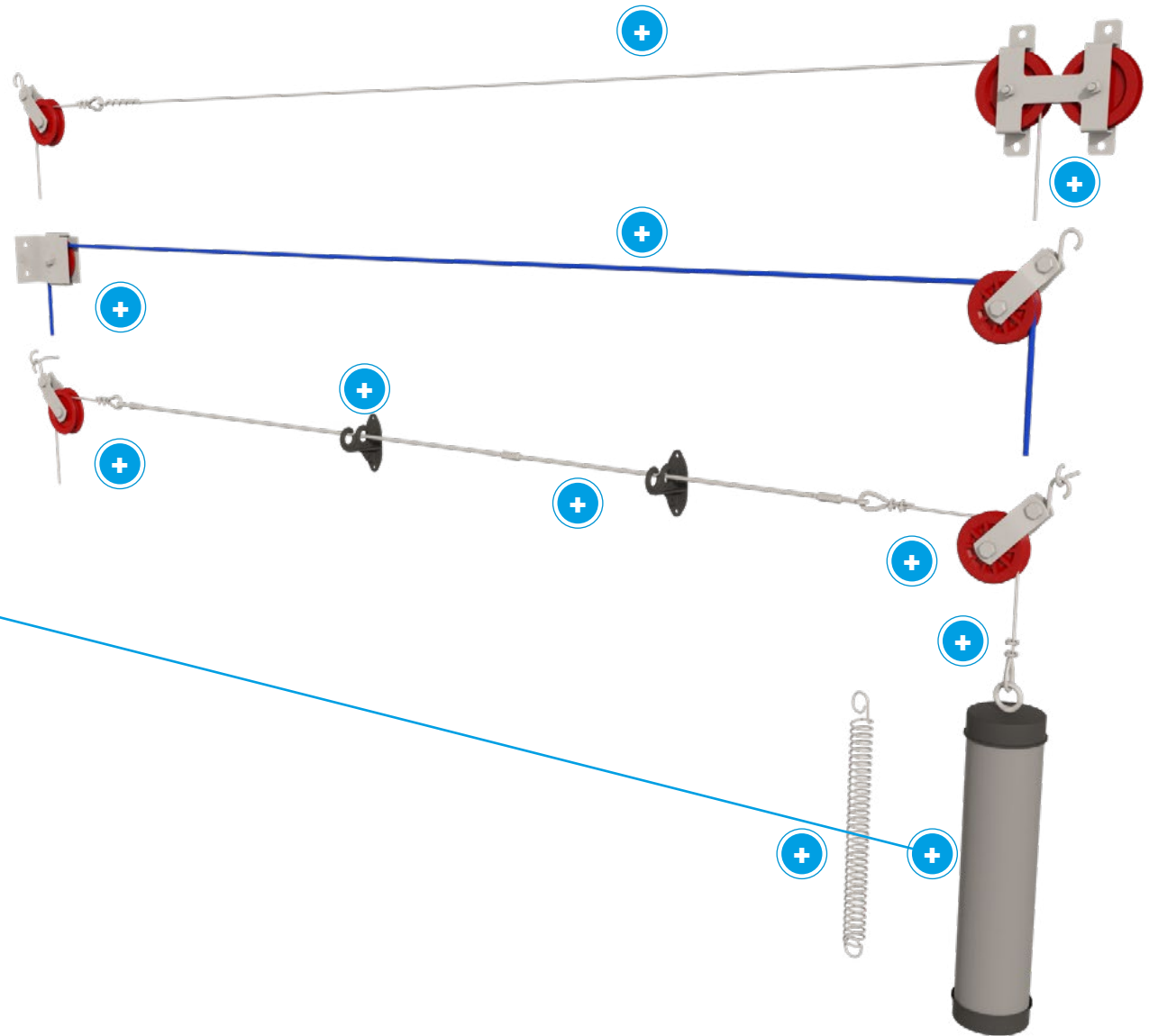



WARRANTY / MAINTENANCE

WARRANTY

TPI-Polytechnik offers a 1 year warranty on manufacturers defects. This warranty covers any defects caused by faulty production or design flaws. For parts that are designed to move, wear and tear there is no warranty as these parts are intended and designed to be replaceable. To find details on which parts are marked as replaceable please contact TPI-Polytechnik for further information.

Since TPI-Polytechnik products are meant to be installed by professionals there is no warranty over installation mishaps or any damage caused by incorrect installation of the products herein. TPI-Polytechnik does offer a service warranty of 1 years over correctly and professionally installed products, therefore we strongly advise to use professional personnel.

Our polyurethane formula guarantees high insulation values but does not in any case guarantee that our products cannot freeze when in low temperatures. To ensure optimal functioning of your product(s) please contact your dealer or TPI-Polytechnik for information on installation, set-up adjustments and functionality.

Please note that under no circumstance TPI-Polytechnik is responsible for injuries or loss of life due to malfunction of our products!

INSTALLATION – SET-UP – MAINTENANCE

Make sure to mount inlets on a flat wall surface

A flat wall surface ensures optimal fitment and therefore air leakage will be reduced to a minimum. For optimal functioning make sure to caulk all sides of the inlet with a silicon sealant.

Layout Main Cable

In the layout, straight lines are recommended. Avoid additional pulleys. For additional information, please consult our support department.

Do not use foams or fillers to fill space in between the inlet and the wall

Foams and fillers might cause damage to the inlet or cause it to jam as they have different expansion values due to temperature differences. When in doubt, please ask your supplier for additional information.

Use screws with rivets for mounting the inlets into the wall, be aware of the polyurethane skin

With the use of rivets for mounting the inlets into the wall one can prevent the screw to sink into the flange or skin of the inlet. The outer skin of the polyurethane is hard but the force exerted on screws during installation might penetrate the skin.

For the set-up, connect the inlet to the main cable when in closed position

Make sure the inlet is closed when connecting it to the main cable, this will ensure all inlets are connected in the same modus and less adjustments are needed to optimize the set-up.

Cleaning

Pay close attention while cleaning the inlets, avoid using corrosive cleaning solutions that might harm the polyurethane. Also make sure not to use too much pressure with the pressure washers as it might damage the skin of the inlets. Use max. 120 bar at a minimal distance of 10cm and temperatures not exceeding 40°C

[BACK](#)

- + CROSS VENTILATION**
- + LONGITUDINAL VENTILATION WITH SIDE-WALL INLET**
- + ROOF VENTILATION**
- + TUNNEL VENTILATION**
- + ROOF TUNNEL VENTILATION**
- + LONGITUDINAL VENTILATION WITH SIDE-WALL INLET AND TUNNEL INLET**
- + CEILING VENTILATION**
- + CHIMNEY VENTILATION**

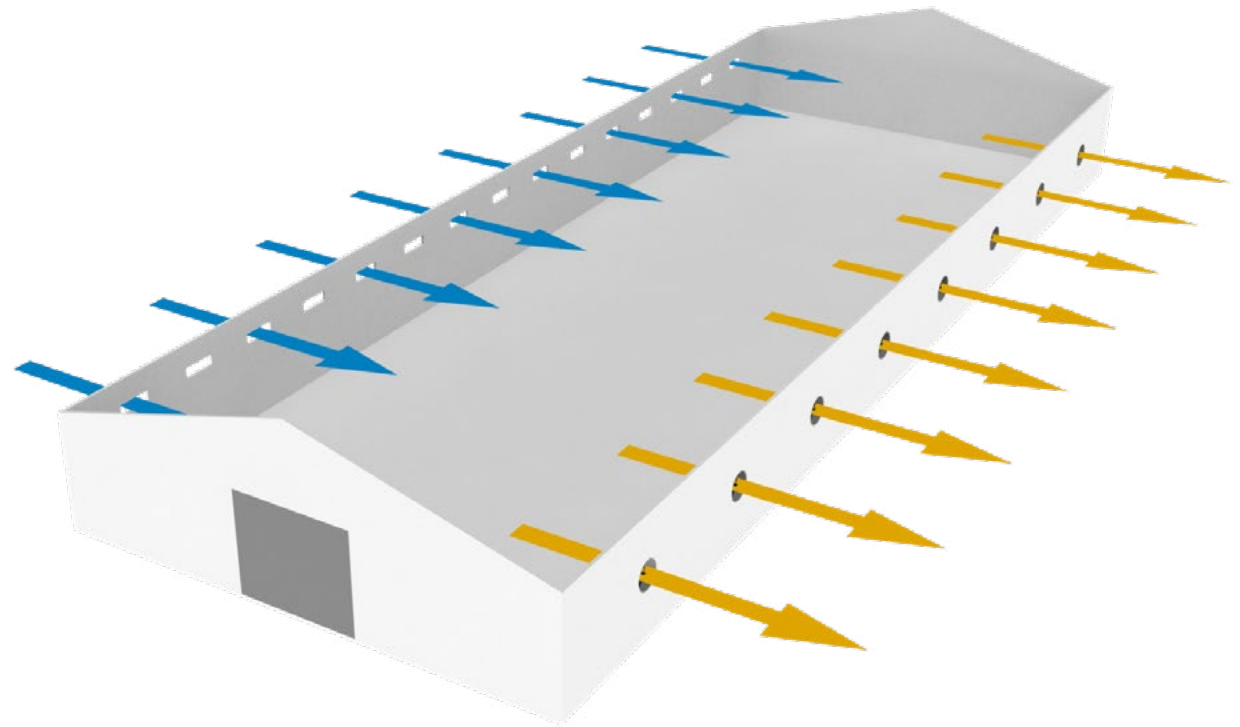

Cross ventilation

The incoming air enters the house through the sidewall inlets. Exhaust air is taken out through fans in the opposite sidewall.



- + CROSS VENTILATION
- + **LONGITUDINAL VENTILATION WITH SIDE-WALL INLET**
- + ROOF VENTILATION
- + TUNNEL VENTILATION
- + ROOF TUNNEL VENTILATION
- + LONGITUDINAL VENTILATION WITH SIDE-WALL INLET AND TUNNEL INLET
- + CEILING VENTILATION
- + CHIMNEY VENTILATION

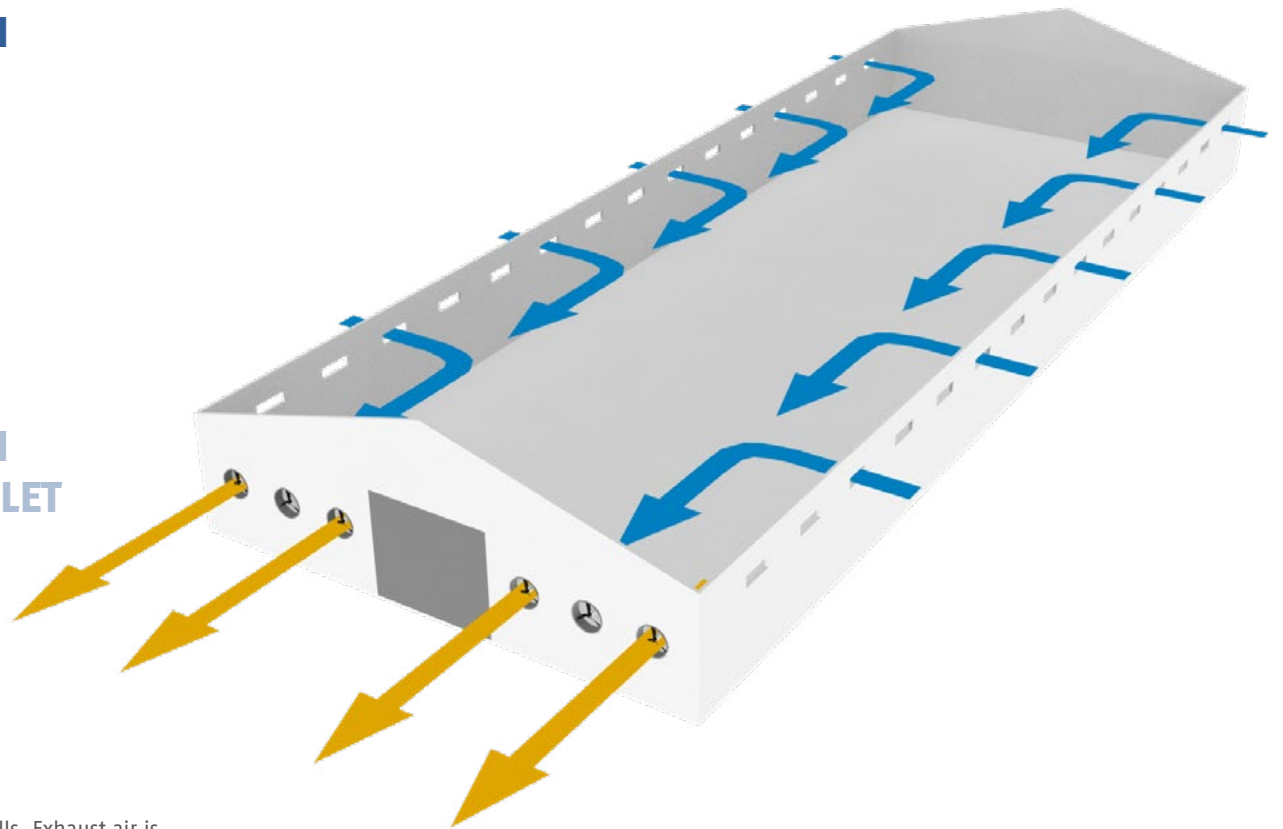

Longitudinal Ventilation with side-wall inlet

The incoming air enters the house through inlets in both sidewalls. Exhaust air is taken out through fans in the end gable.



- + CROSS VENTILATION
- + LONGITUDINAL VENTILATION WITH SIDE-WALL INLET
- + **ROOF VENTILATION**
- + TUNNEL VENTILATION
- + ROOF TUNNEL VENTILATION
- + LONGITUDINAL VENTILATION WITH SIDE-WALL INLET AND TUNNEL INLET
- + CEILING VENTILATION
- + CHIMNEY VENTILATION

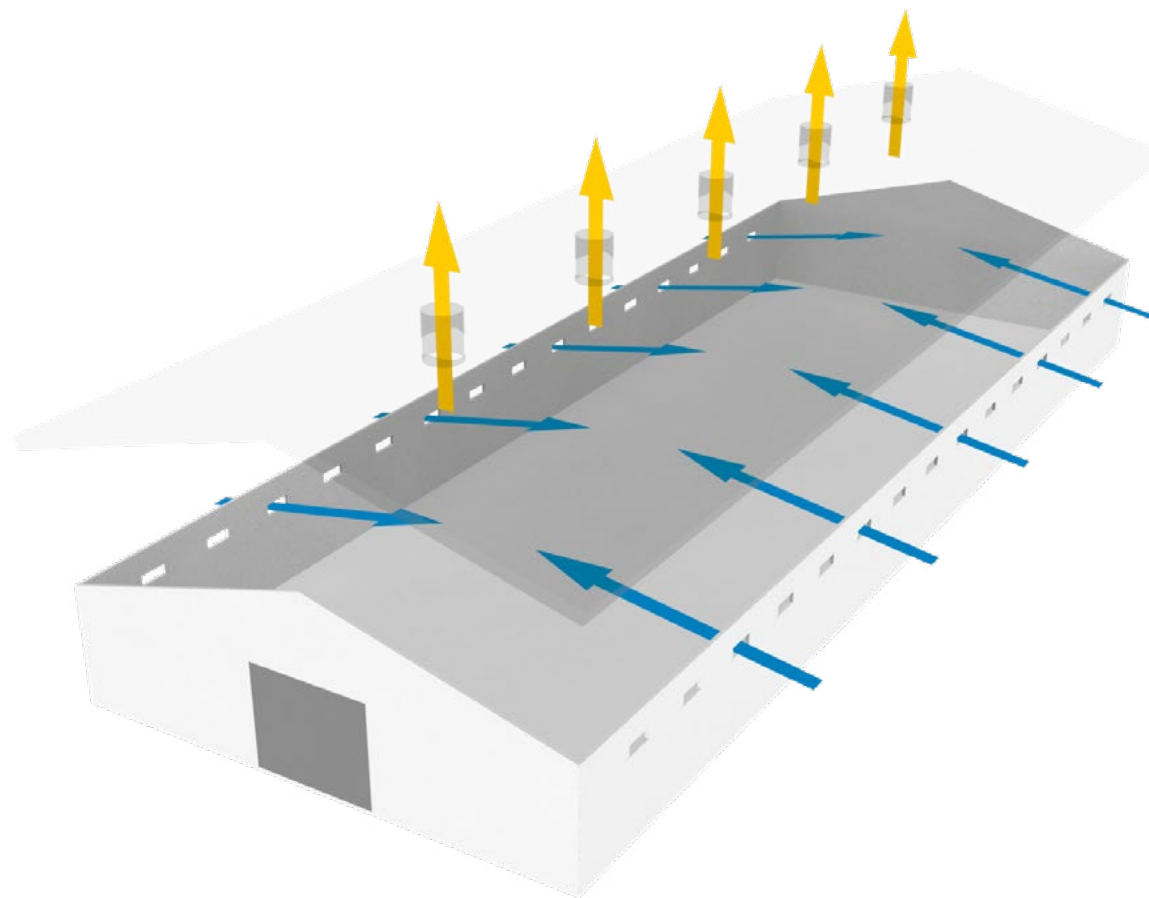

Roof ventilation

The incoming air enters the house through inlets in both sidewalls. Exhaust air is taken out of the house through ventilation chimneys.

- + CROSS VENTILATION
- + LONGITUDINAL VENTILATION WITH SIDE-WALL INLET
- + ROOF VENTILATION
- + **TUNNEL VENTILATION**
- + ROOF TUNNEL VENTILATION
- + LONGITUDINAL VENTILATION WITH SIDE-WALL INLET AND TUNNEL INLET
- + CEILING VENTILATION
- + CHIMNEY VENTILATION

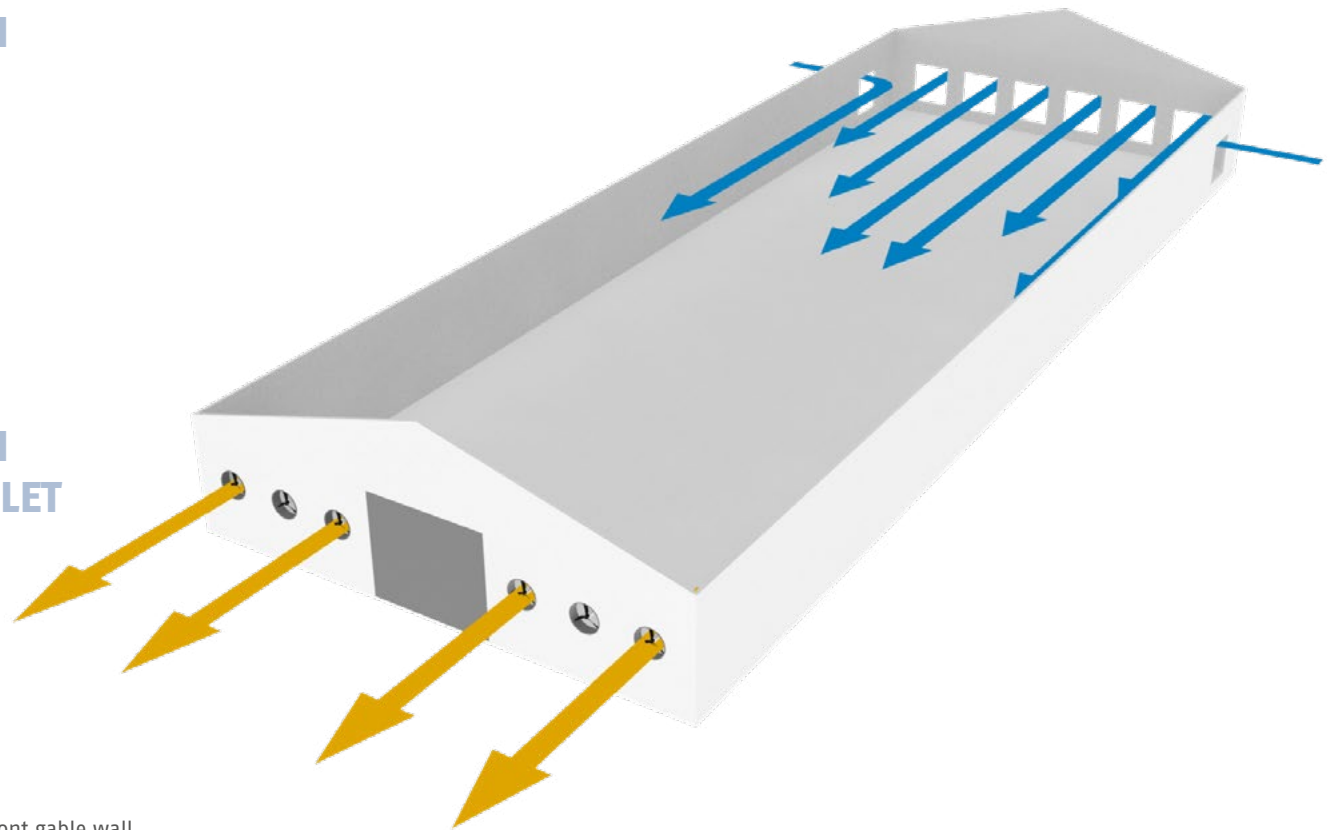

Tunnel ventilation

The incoming air enters the house through tunnel units in the front gable wall.

Exhaust air is taken out through fans in the end gable.



- + CROSS VENTILATION
- + LONGITUDINAL VENTILATION WITH SIDE-WALL INLET
- + ROOF VENTILATION
- + TUNNEL VENTILATION
- + ROOF TUNNEL VENTILATION**
- + LONGITUDINAL VENTILATION WITH SIDE-WALL INLET AND TUNNEL INLET
- + CEILING VENTILATION
- + CHIMNEY VENTILATION

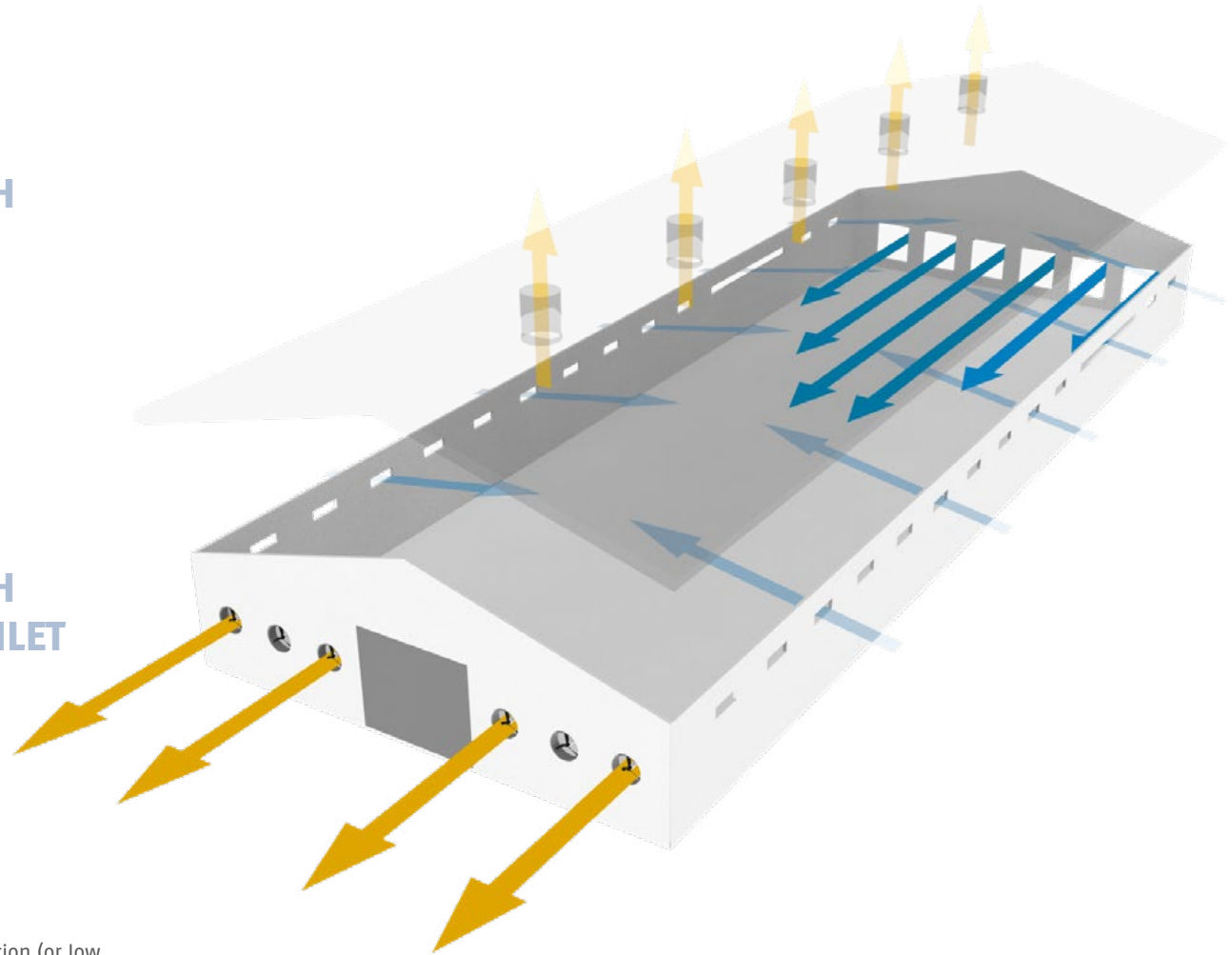

Roof tunnel ventilation

This is a combination of two concepts. During minimum ventilation (or low temperatures) the air enters through air inlet valves in both sidewalls. Exhaust air is taken out of the house via exhaust chimneys. During maximum ventilation, the tunnel units are opened and the airspeed increases in order to cool the animals. Big exhaust fans in the end gable take the air out.



- + CROSS VENTILATION
- + LONGITUDINAL VENTILATION WITH SIDE-WALL INLET
- + ROOF VENTILATION
- + TUNNEL VENTILATION
- + ROOF TUNNEL VENTILATION
- + LONGITUDINAL VENTILATION WITH SIDE-WALL INLET AND TUNNEL INLET**
- + CEILING VENTILATION
- + CHIMNEY VENTILATION

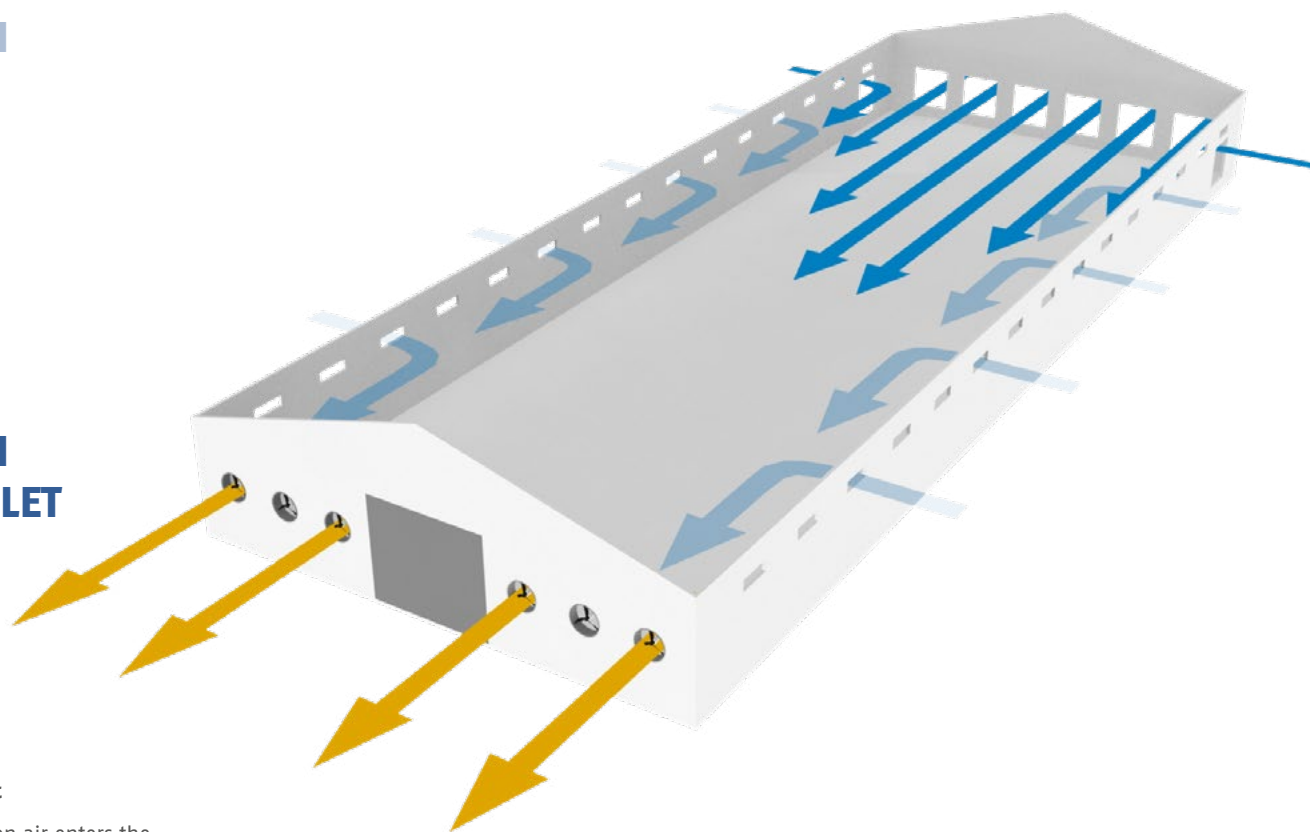

Longitudinal Ventilation with side-wall inlet and tunnel inlet

This is a combination of two systems. During minimum ventilation air enters the house through inlets in both sidewalls. Exhaust air is taken out via fans in the end gable. During maximum ventilation the incoming air enters the house through tunnel units in the front gable. Exhaust air is taken out through fans in the end gable.



- + CROSS VENTILATION
- + LONGITUDINAL VENTILATION WITH SIDE-WALL INLET
- + ROOF VENTILATION
- + TUNNEL VENTILATION
- + ROOF TUNNEL VENTILATION
- + LONGITUDINAL VENTILATION WITH SIDE-WALL INLET AND TUNNEL INLET
- + **CEILING VENTILATION**
- + CHIMNEY VENTILATION

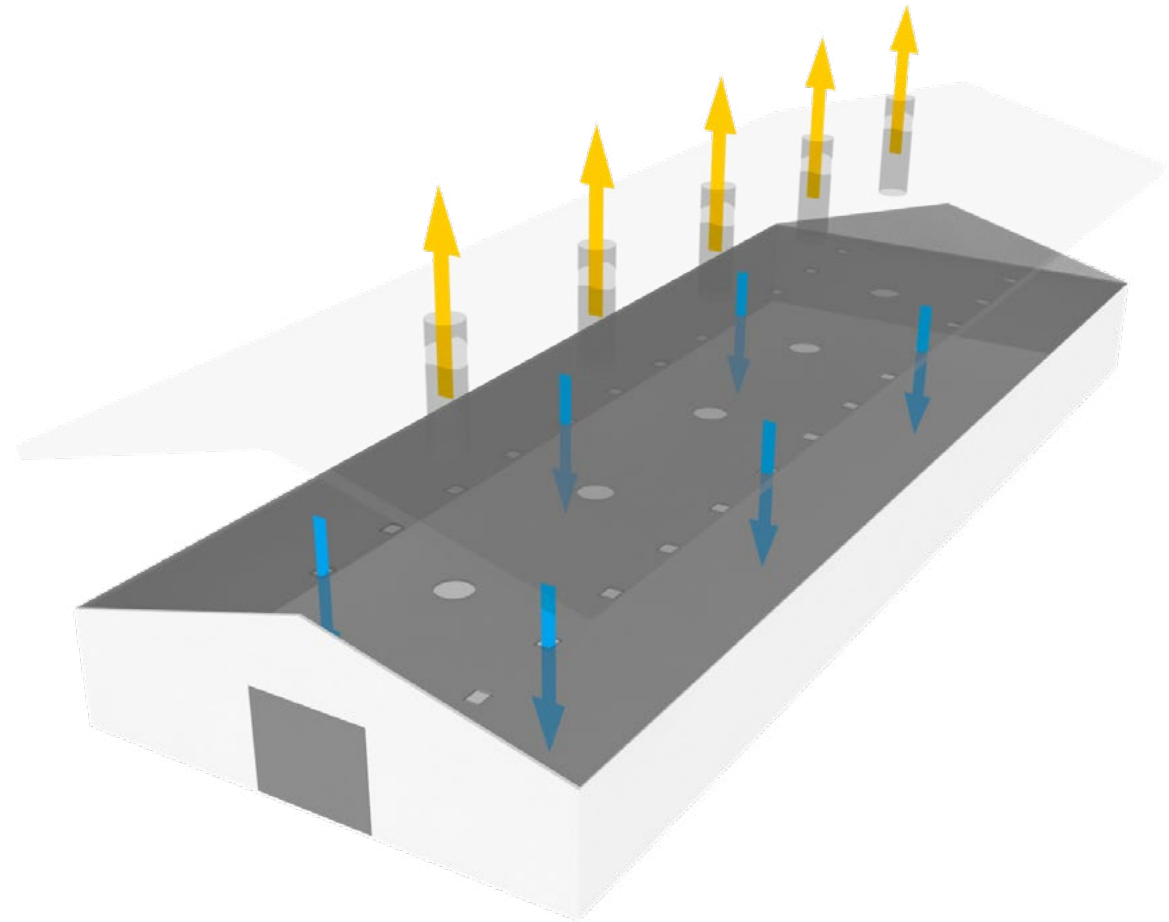

Ceiling ventilation

The incoming air enters the house through ceiling inlets. Exhaust air is taken out of the house through ventilation chimneys.



VENTILATION CONCEPTS

- + CROSS VENTILATION
- + LONGITUDINAL VENTILATION WITH SIDE-WALL INLET
- + ROOF VENTILATION
- + TUNNEL VENTILATION
- + ROOF TUNNEL VENTILATION
- + LONGITUDINAL VENTILATION WITH SIDE-WALL INLET AND TUNNEL INLET
- + CEILING VENTILATION
- + **CHIMNEY VENTILATION**

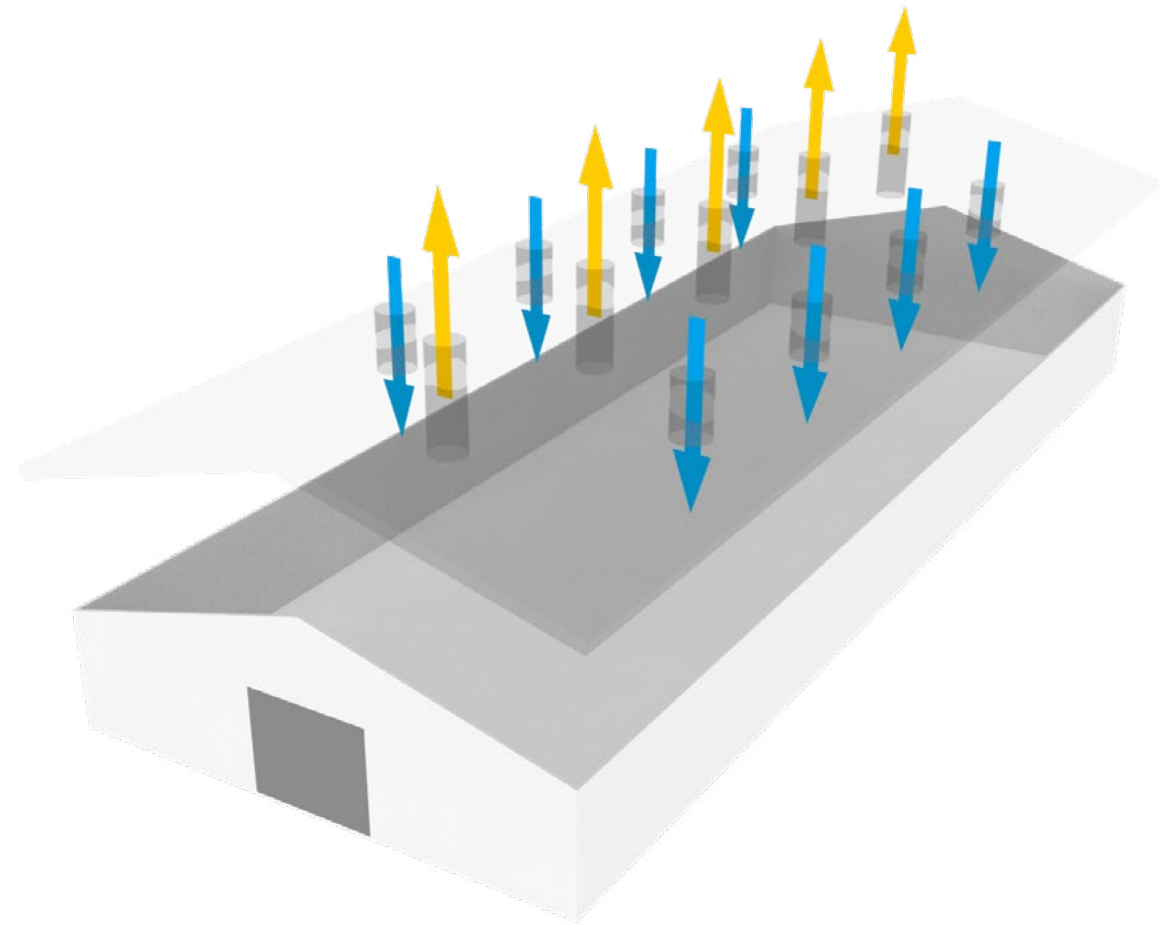

Chimney ventilation

The incoming air enters the house through ventilation chimneys and exhaust air is also taken out through ventilation chimneys.

